



WATER STANDARDS MANUAL



Current Revision Date:

January 2022

WATER STANDARDS MANUAL

Contents

| | |
|--|----|
| REVISION SUMMARY | 6 |
| SECTION 1.0 INTRODUCTION | 9 |
| 1.01 Purpose | 9 |
| 1.02 Scope | 9 |
| 1.03 Procedures | 9 |
| 1.04 References | 9 |
| 1.05 Regulatory Procedures | 10 |
| 1.06 Application Procedure for Water Main Installation | 10 |
| 1.07 Application Procedure for Service Lines | 10 |
| 1.08 Plans | 11 |
| 1.09 Engineering Design | 11 |
| 1.10 Upsizing of Water Mains | 11 |
| 1.11 Surveying | 11 |
| 1.12 Inspection | 12 |
| 1.13 Contractors | 12 |
| 1.14 Other Agency Requirements | 12 |
| SECTION 2.0 DESIGN, LAYOUT AND EASEMENT STANDARDS FOR WATER MAIN INSTALLATION | 13 |
| 2.01 General | 13 |
| 2.02 Design Standards | 13 |
| 2.03 Layout Standards | 14 |
| 2.04 Easement Requirements | 18 |
| SECTION 3.0 DESIGN AND LAYOUT STANDARDS FOR SERVICE LINES | 20 |
| 3.01 General | 20 |
| 3.02 Design Standards | 20 |
| Table 3.1 Services Requiring Design Submittals | 20 |
| 3.03 Layout Standards | 21 |
| 3.04 Irregular Services | 22 |
| 3.05 Association Agreements | 22 |
| SECTION 4.0 PROJECT SUBMITTALS FOR WATER MAIN INSTALLATION | 24 |
| 4.01 Purpose | 24 |
| 4.02 Required Drawing Submittal Medium | 24 |
| 4.03 Submittals | 24 |
| 4.04 Dry Main Installation Requests | 27 |
| SECTION 5.0 APPLICATION FOR SERVICE LINES | 28 |

| | | |
|---|---|----|
| 5.01 | Purpose | 28 |
| 5.02 | General | 28 |
| 5.03 | Domestic Service | 29 |
| 5.04 | Fire Protection Service | 29 |
| 5.05 | Requirements for New Irrigation Systems | 30 |
| SECTION 6.0 PLUMBER'S INFORMATION | | 34 |
| 6.01 | Purpose | 34 |
| 6.02 | Conformance to Standards | 34 |
| 6.03 | Application for Service | 34 |
| 6.04 | Bond | 34 |
| 6.05 | Maintenance of Service Line | 34 |
| SECTION 7.0 MATERIAL REQUIREMENTS FOR WATER MAINS | | 35 |
| 7.01 | General | 35 |
| 7.02 | Polyvinyl Chloride (PVC) Pipe (6" and 8" Diameter) | 35 |
| 7.03 | Ductile Iron Pipe and Fittings | 35 |
| 7.04 | Polyethylene (HDPE) Pipe and Fittings (3" through 36" Diameter) | 37 |
| 7.05 | Valves | 37 |
| Table 7.1 Valve Opening Orientation | | 38 |
| 7.06 | Tapping Sleeves | 38 |
| 7.07 | Hydrants | 40 |
| Table 7.07.1 Fire Hydrant Specifications | | 40 |
| 7.08 | Valve Box, Lid and Riser | 41 |
| 7.09 | Blow-off Assembly (3" through 24" Water Mains) | 41 |
| 7.10 | Blow-off Assembly (30" and Larger Water Mains) | 41 |
| 7.11 | Air Relief Valves (16" and Larger Diameter Water Mains) | 42 |
| 7.12 | Mechanical Joint Restraint Devices | 42 |
| 7.13 | Ductile Iron Bell Joint Restraint Devices | 42 |
| 7.14 | PVC Bell Joint Restraint Devices | 42 |
| 7.15 | Polyethylene Encasement | 43 |
| 7.16 | Service Saddles and Corporation Stops | 43 |
| 7.17 | Tracing Wire, Splicing Connectors and Test Stations | 44 |
| 7.18 | Identification Ribbon | 45 |
| 7.19 | Casing Pipe | 45 |
| 7.20 | Vaults | 46 |
| 7.21 | Yard Hydrant | 46 |
| SECTION 8.0 MATERIAL REQUIREMENTS FOR SERVICE LINES | | 47 |
| 8.01 | General | 47 |

| | | |
|------|---|----|
| 8.02 | Polyvinyl Chloride (PVC) Pipe (4" through 8" Diameter) | 47 |
| 8.03 | Ductile Iron Pipe and Fittings | 47 |
| 8.04 | Polyethylene (HDPE) Pipe and Fittings (3/4" through 2" Diameter) | 49 |
| 8.05 | Polyethylene (HDPE) Pipe and Fittings (3" through 12" Diameter) | 49 |
| 8.06 | Copper Tubing and Fittings | 50 |
| 8.07 | Galvanized Pipe and Nipples | 50 |
| 8.08 | Brass Nipples and Fittings | 51 |
| 8.09 | Gaskets | 51 |
| 8.10 | Dielectric Bushings | 51 |
| 8.11 | Valves | 51 |
| | Table 8.11.1 Valve Opening Orientation | 52 |
| 8.12 | Inlet and Outlet Valves | 52 |
| 8.13 | Valve Box, Lid and Riser (>4" valves installed within public right-of-way or easements) | 52 |
| 8.14 | Valve Box, Lid and Riser (1 1/2" and 2" Curb Stops) | 53 |
| 8.15 | Blow-off Assembly (3" through 12" Service Lines) | 53 |
| 8.16 | Joint Restraint Devices | 53 |
| 8.17 | Cross-Laminated Polyethylene Encasement | 53 |
| 8.18 | Service Saddles and Corporation Stop | 54 |
| 8.19 | Tracing Wire/Splicing Connectors | 55 |
| 8.20 | Identification Ribbon | 55 |
| 8.21 | Casing Pipe | 55 |
| 8.22 | Vaults | 56 |
| 8.23 | Meter Pits | 57 |
| 8.24 | Insulated Enclosures | 57 |
| 8.25 | Backflow Protection Devices | 58 |
| 8.26 | Installation of Flow Reducers | 58 |
| | SECTION 9.0 INSTALLATION REQUIREMENTS FOR WATER MAINS AND SERVICE LINES | 59 |
| 9.01 | General | 59 |
| 9.02 | Material Handling and Storage | 61 |
| 9.03 | Public Utilities | 61 |
| 9.04 | Alignment and Grade | 62 |
| 9.05 | Trench Excavation, Preparation and Backfill | 62 |
| | Table 9.05.1 Trench Widths for Ductile Iron Pipe | 63 |
| | Table 9.05.2 Trench Widths for PVC Pipe | 63 |
| 9.06 | Erosion Control | 64 |
| 9.07 | Contaminated Soils | 64 |

| | | |
|--|--|----|
| 9.08 | Service Taps..... | 65 |
| 9.09 | Pipe Installation..... | 65 |
| 9.10 | Casing Pipe..... | 70 |
| 9.11 | Stream Crossing | 71 |
| 9.12 | Valves, Valve Boxes, Fittings and Blow-offs | 72 |
| 9.13 | Setting Meter Pits, Vaults and Hot Boxes | 73 |
| 9.14 | Hydrants | 73 |
| 9.15 | Thrust Blocking..... | 74 |
| 9.16 | Pipe Joint Restraint Devices | 75 |
| 9.17 | Installation of Tracing Wire and Identification Ribbon..... | 75 |
| 9.18 | Polyethylene Wrap..... | 76 |
| 9.19 | Charging, Flushing, Air Removal and Hydrostatic Testing..... | 76 |
| 9.20 | Disinfection of Water Mains and Service Lines..... | 76 |
| 9.21 | Connection with Existing Distribution System | 77 |
| 9.22 | Restoration..... | 78 |
| 9.23 | Additional Items..... | 80 |
| 9.24 | Construction Record Measurements | 80 |
| 9.25 | Dry Main Installation..... | 81 |
| 9.26 | Water Main/Service Line Repairs on Warranted Work | 81 |
| 9.27 | Water Main/Service Line Safety Issues..... | 82 |
| APPENDIX A- Abbreviations and Definitions..... | | 84 |
| A. | Abbreviations..... | 84 |
| B. | Definitions..... | 85 |
| APPENDIX B- Water Distribution Plans..... | | 87 |
| A. | General..... | 87 |
| B. | Software Requirements | 87 |
| C. | Digital Registration | 87 |
| D. | Department Standards | 87 |
| E. | Paper/Model Space..... | 87 |
| F. | <i>base100.dwg</i> (Overall Development Plan, Preliminary Plat and Final Plat) | 87 |
| H. | <i>ppbase50.dwg</i> (Plan and Profile Base Sheet)..... | 88 |
| I. | Line Work..... | 88 |
| J. | Blocks | 88 |
| K. | Layer Control | 91 |
| L. | Record Drawings..... | 93 |
| APPENDIX C- Construction Testing Methods..... | | 94 |

Revisions Summary

| Section | Revisions |
|--|--|
| Section 2.03A - Separation from Other Utilities | <p>Change title of Section A from "Sewer and Water Main Separation" to "Water Main Separation from Other Utilities".</p> <p>After the link to IAC, add "Water main shall be a minimum of 3' from other utilities including Telcom, gas, electric, fiber optic."</p> <p>Change "...Water and Sewer Main Separation Detail..." to "...Water Main Separation from Other Utilities..."</p> |
| Section 2.03B - Easements | Add "Along frontages of new developments and extension from existing water main to the frontage of a new development, water main must be located within a minimum 20' easement adjacent to the right-of-way." |
| Section 2.03E - Minimum Fitting Sizes | Add "Bends shall be no greater than 45° for 8" diameter mains and no greater than 22.5° for 12" diameter mains and larger." |
| Section 2.03 G & H-Hydrant Spacing-Blow Off Assemblies | <p>Per Westfield Fire Marshall, James Roberts, the department is requesting a change to our standards regarding the existing 300' hydrant spacing requirement. They propose that Citizens Westfield amends the standard to reflect the 500' spacing that's currently in place for all other Citizens territories. (Section 2.03 G)</p> <p>The department has also requested the elimination of hydrants being utilized at dead end main locations, and instead, adopting the use of the typical blow off assemblies. Again, same as all other Citizens territories. (Section 2.03 H)</p> |
| Section 3.03 A, Sewer and Service Line Separation | <p>Change title of A. from "Sewer and Service Line Separation" to "Service Line Separation from Other Utilities"</p> <p>In A, modify as follows:</p> <p>After "...per 327 IAC 8-3.2-9", add the following sentence "Water service shall be a minimum of 3' from other utilities including Telcom, gas, electric, fiber optic."</p> <p>Change "...Water and Sewer Main Separation Detail..." to "...Water Main Separation from Other Utilities..."</p> |
| Section 3.03 B - Distance from Property Lines | Add the following as a new paragraph at the end of B. "A service line must be installed a minimum of 5' from adjoining property line." |
| Section 3.03 D. Location of Fire Line Riser | <p>Add the following as item D. and update lettering of existing items to E. through G.</p> <p>"D. Location of Fire Line Riser</p> <p>"A new fire line riser shall be turned up within 5' of the building penetration."</p> |

| Section | Revisions |
|---|---|
| Section 5.04-B6 Fire Protection Services with a Fire Pump | Add "with a 20-psi minimum setpoint." at the end. |
| Section 8.06 A | Replace "WESTFIELD – Copper tubing shall be prohibited in Westfield unless otherwise approved by the Utility." with "WESTFIELD – For internal meter sets, copper tubing may extent from the floor penetration to 5' outside of the building. All other uses of copper tubing shall be prohibited in Westfield unless otherwise approved by the Utility." |
| Section 8.18 A Service Saddles and Corporation Stop | 3. replace A192 with A193 4. replace A193 with A194 |
| Section 8.18 B- Service Saddles and Corporation Stop | <p>Delete Section 8.18 B step 4 O-rings on top and bottom shall be provided to seal the valve and step 7 Shall be plug style valves</p> <p>Add steps Molded EDPM rubber seal with reinforcing ring supports the ball, solid one-piece tee-head and stem, duel EDPM O-rings in the stem, 300 psi working pressure.</p> <p>Based on descriptions above, changes to 8.18 B are:</p> <p>Replace current items 1-5 as follows:</p> <ol style="list-style-type: none"> 1. "Tap shall be easy turning, O-ring sealed, balanced pressure ball valve having a round, full-open, unobstructed flow way and working pressure of 300 psi. 2. Body shall have AWWA taper threads on inlet. 3. Operating head shall be large enough to provide adequate wrench gripping area. 4. Molded EDPM rubber seat with reinforcing ring supports the ball. 5. Solid one-piece tee-head and stem with dual EDPM O-rings in the stem." <p>Delete item 7 and renumber items 8 and 9.</p> |
| Section 9.09 D 2 | <p>Change Section 9.09 D2:</p> <p>To help minimize the effects of thermal contraction and expansion for HDPE pipe, water stops shall be installed as shown on CW Standard Practice Drawing "U" Minimum Requirements for Water Stop Installation and U.1 Flexible Restraints Saddles.</p> <p>Water stops shall be required at every change in materials. Use Compression fitting with concrete collar for 1-1/2" and 2" pipes. Use a fused poly collar for 3" and larger pipe</p> |
| Section 9.12- Valves, Valve Boxes, Fittings and Blow-offs | Section 9.12B and 9.12C state "WESTFIELD - Refer to Standard Drawing for Westfield Gate Valve and Box", however a separate Westfield valve and valve box detail does not exist. Remove reference to separate detail or create a separate Westfield valve and valve box detail |
| Section 9.13-Setting Meter Pits, | Replace the first paragraph of 9.13A with "An inside meter setting/backflow preventer must be installed at the point of entry to the |

| Section | Revisions |
|---|--|
| Vaults and Hot Boxes | building (within 5' of the exterior wall) and must always be accessible and testable. Refer to Standard Practice Drawings T.4 or T.WF7." |
| Section 9.21.A Connection with Existing Distribution System | <p>Change third paragraph to:</p> <p>If a new connection is the same pipe diameter as the existing water main, the Utility or its approved contractor will install a cut-in tee to protect the integrity of the distribution system. Ductile iron main will be the only exception, all size-on-size tap connections on cast iron, polyethene and PVC will require cut in tees.</p> <p>Remove "For all pipe material except ductile iron, the Utility or its approved contractor will install a cut-in tee for a new connection that is the same pipe diameter as the existing water main to protect the integrity of the distribution system. For ductile iron pipe, the Utility or its approved contractor will make a tap for a new connection that is the same pipe diameter as the existing water main to protect the integrity of the distribution system."</p> |
| Drawing A-Water and Sewer Main Separation Detail | Rename detail to "Water Main Separation from Other Utilities" and update two callouts. |
| Drawing G-Standard 8" Valve Box and Cover | Update valve box lid dimensions using information from Star Pipe Product and add tracing wire information. |
| Drawing U-1 | U.1 Flexible Restraints Saddles |
| Drawings T.WF1,T.WF3,T.WF5 | Updated Water Meter Pit Lid Manufacturer info |
| APPENDIX A- Abbreviations and Definitions | Replace the definition of CONTRACTOR with the following definition: Any Contractor who meets the Utility's requirements to perform the work of installing water lines under the Utility's jurisdiction. |

SECTION 1.0 INTRODUCTION

1.01 Purpose

The intent of the Water Standards Manual is to provide criteria for a consistently high level of engineering design, construction materials, construction methods, and project documentation of the well lines, transmission mains, water mains and service lines installed within Citizens Energy Group's (Utility) service area. Standards specific to Westfield begin with "**WESTFIELD –... "**.

The Developer/Contractor shall be responsible for using the current versions of these standards and referenced regulations.

1.02 Scope

All water mains and service lines installed to serve the customers, an individual, firm, corporation, government agency or other entity being supplied with water utility service, shall be designed, constructed and documented as outlined in these Standards. Proposed departures or special circumstances from the Standards shall require approval from the Utility. At no time will any modification to the Standards be allowed without direct approval from the Utility and could result in a potentially detrimental situation by which the integrity of the Utility's potable water is at risk.

1.03 Procedures

The Standards describe the initiation of a project, design of the proposed water mains, materials to be used in construction, approved installation methods, and the documentation required for Utility records. If the Standards and/or additional specific instructions given by the Utility are not followed, project approval for construction may be delayed and/or denied. Failure to submit any specified items may cause a delay in the approval of a project by the Utility. The Developer, an individual or entity that develops real estate, especially by preparing a site for residential or commercial use and requires water utility service, is directly responsible for all project receivables and the information contained therein.

The sections of these Standards related to service lines address the initiation of a service line by a customer, design of the proposed service lines as required per Section 3.02A, materials to be used in construction, approved installation methods, and the documentation required for Utility records. If the Standards and/or additional specific instructions given by the Utility are not followed, project approval for construction may be delayed and/or denied. Failure to submit any specified items may cause a delay in the approval of a project by the Utility. The customer is directly responsible for all project receivables and the information contained therein.

1.04 References

Regulations and specifications of the following organizations are referenced in this document:

- A. American Water Works Association (AWWA)
- B. American National Standards Institute (ANSI)
- C. American Society of Testing and Materials (ASTM)
- D. Indiana Administrative Code (IAC)
- E. Indiana Department of Environmental Management (IDEM)

- F. Indiana Utility Regulatory Commission (IURC)
- G. National Sanitation Foundation (NSF)
- H. Underwriters Laboratories (U/L)

The Developer/Contractor shall be responsible for using the current versions of these standards and referenced regulations.

1.05 Regulatory Procedures

The Design Engineer is responsible for ensuring all water main extensions and service lines are within regulatory compliance with all applicable Local, State, and Federal agencies and the applicable Utility rules for water main extensions and service line installations.

1.06 Application Procedure for Water Main Installation

These procedures outline the requirements for documentation, submittals, fees, design, construction and acceptance of the proposed water main extension.

The submittals shall conform to the requirements outlined in Section 4.0-Project Submittals for Water Main Installations of the Standards.

The Utility shall return to the Developer its requirements for:

1. Point(s) of connection to existing facilities.
2. Sizes of mains to be installed.
3. Location of system features (i.e. valves, hydrants, blow-offs, sample stations, and associated appurtenances).
4. Participation requirements, if any, to the proposed project.

All water main extension plans, and specifications shall be prepared by, or under the direct supervision of a Professional Engineer licensed in the State of Indiana, as outlined In Section 4.0-Project Submittals for Water Main Installations of the Standards.

1.07 Application Procedure for Service Lines

These procedures outline the requirements for documentation, submittals, fees, design, construction, and acceptance of the proposed service lines.

The initial submittal from the customer shall conform to the requirements identified in sections 5.02, 5.03, 5.04 and 5.05 of these Standards.

The Utility shall return to the customer its requirements for:

1. Point(s) of connection to existing facilities.
2. Sizes available for services to be installed.
3. Location of service features (i.e. branch valves, private hydrants, blow-offs, and associated appurtenances).

The customer shall submit final plans for review by the Utility, as outlined in Section 5.0- Application of Service Lines of these Standards.

If a property abuts to more than one Citizens main, a Utility representative will determine which main shall be tapped.

1.08 Plans

All water main extension plans and required service line plans as required per Section 3.02A shall be submitted in strict compliance with the engineering standards contained herein and any special conditions shall be approved by the Utility. The submittal shall meet the requirements identified in Section 4.0, Project Submittals for Water Main Installation.

Construction shall not commence until all necessary project submittals are received and the project has been released for construction by the Utility. If construction does not commence within one (1) year of the plan approval, plans shall be resubmitted for approval.

1.09 Engineering Design

All water main extension plans and specifications, as well as service lines that require plans be submitted to the Utility for review, comment, and approval or modification shall be prepared by, or under the direct supervision of a Professional Engineer licensed in the State of Indiana acting as the Design Engineer. The Design Engineer shall be responsible for design, plan preparation, selection of materials, and conducting the field survey in accordance with the Standards. All submitted plans shall bear the Professional Engineer's seal, signature, and date prior to final review of the plans for compliance with these Standards by the Utility.

All applicants for commercial water services are required to provide an estimation of the proposed daily domestic-water demand at their project site. This demand should be calculated in accordance with 327 IAC 8-3.3, and it must be reported for all new water services implementing one 2-inch water meter, two dual operating 1-1/2-inch water meters, or anything larger.

If the Design Engineer does not agree with changes to the submitted plans required by the Utility as a result of its review, such disagreement shall be brought to the attention of the Utility for resolution prior to resubmitting plans for approval.

1.10 Upsizing of Water Mains

If the future extension plans require a larger main size than is required for the development, the difference in the cost for the larger main size and increased material and installation cost, if any, shall be determined by the Utility.

1.11 Surveying

Line and grade for water mains shall be established by the Developer or the Developer's authorized representative in accordance with these Standards. A baseline reference shall be established and used to identify all facilities for record drawings. This baseline shall typically be the centerline of the public right-of-way, or the centerline of pavement for private roads. Easements not aligned with a public or private road shall reference one side of the easement as the baseline.

Line and grade for service lines shall be established by the customer and their authorized representative in accordance with these Standards prior to final connection to the existing distribution system.

1.12 Inspection

Installation of all new facilities shall be inspected and approved by the Utility in accordance with these Standards prior to final connection to the existing distribution system. All work shall be performed in strict compliance with the Utility approved plans. All applicable permits shall be available for inspection at the jobsite.

The water main installation Contractor, a company or person with a formal contract with the Developer to install a water main, shall provide three (3) working days' notice to the Utility immediately prior to starting construction.

The service line Contractor shall provide two (2) working days' notice to the Utility prior to starting construction.

1.13 Contractors

No water main installation work shall commence until a pre-construction meeting has been conducted and a Utility approved set of plans has been issued to the Contractor. Attendees at the pre-construction meeting shall include at a minimum, representatives of the Developer, Contractor, and the Utility. All work shall be performed in strict compliance with the Utility approved plans by a bonded Contractor. Contractors on the Utility's disqualified list are prohibited from installing water mains or service lines.

Contractors will be placed on the Utility's disqualified list for any of the following actions:

1. Starting construction prior to the required pre-construction meeting.
2. Starting construction prior to receipt of Utility approved plans.
3. Any service and/or main connections to the existing water utility system without Utility approval and without a Utility inspector present.
4. Operation of existing water system valves, hydrants or other facilities without Utility authorization.
5. Removal or relocation of existing valves, hydrants or facilities without Utility authorization.
6. Failure to address maintenance deficiencies within 30 days of notification by the Utility.
7. Past performance of the Contractor.
8. Losing bonding.

No service line installation work shall commence until the Contractor has a Utility approved set of plans in their possession that is separate from the main installation approval. All work shall be performed in strict compliance with the Utility approved plans by a bonded Contractor.

1.14 Other Agency Requirements

When applying for a water main extension, new service line or any change of an existing service line, special conditions that involve another agency, such as crossing a railroad or a highway, may exist. All conditions of the other agency must be satisfied. All designs, drawings and calculations submitted to another agency that affect the proposed water main extension, service line or modification of an existing service line shall be submitted to the Utility for approval.

END OF SECTION

SECTION 2.0 DESIGN, LAYOUT AND EASEMENT STANDARDS FOR WATER MAIN INSTALLATION

2.01 General

In order to assist the Developer and the Design Engineer with the layout and design of the water main for proposed projects, the following standards are provided.

2.02 Design Standards

These standards provide a minimum design guideline outlining the Utility's requirements to assure the safe, reliable delivery of potable water to its customers.

A. Design Responsibility

The Utility requires that a registered Professional Engineer, licensed in the State of Indiana, oversee, and approve the design all water main extensions. The Design Engineer shall be responsible to assure that the overall design of the proposed water facilities meets all Federal, State, and Local requirements.

The Design Engineer shall use information provided by the Utility as well as their unique knowledge of the proposed project to properly design the water main extensions. The Utility's review of the Design Engineer's plans does not constitute engineering design, but rather verifies that the proposed facilities and submittals meet the minimum Utility Standards.

If the Design Engineer disagrees with the Utility's sizing of mains, location requirements for mains, valves, hydrants, and appurtenances, or any other matter that they believe conflicts with the proper design of the water main, they shall bring such disagreement to the attention of the Utility, so that the conflict can be resolved.

The Design Engineer shall be responsible for submittal of the completed Indiana Department of Environmental Management (IDEM) Notice of Intent (NOI) to the Utility. The NOI shall be completed, signed by the Developer and Design Engineer, and ready for the Utility's authorized representative to sign. Consideration should be given to the anticipated construction schedule when submitting this document to the Utility. Construction cannot commence without an approved NOI.

B. Conformance to Utility's Master Plan

To ensure continued development of an integrated water system, all water main extensions shall conform to the Utility's Master Plan in sizing and general location. Information provided to the Utility by the Developer and Design Engineer will be used to size the mains for the proposed project and verify conformance to the Master Plan. The Utility will then provide the Developer and Design Engineer with the required main size for their use in designing the water main extensions.

All water mains shall be sized to provide for maximum daily demand plus fire protection flows to the respective project areas. The fire protection flow requirements for residential areas are 1,000 gpm at 20 psi and for non-residential areas are 1,500 gpm at 20 psi. All water main extensions and service line requests shall be evaluated using the current hydraulic model.

For a new fire service connection, the Developer or Applicant shall submit a request for a hydrant flow test to the Utility. The flow test results must have a static and

residual pressure of at least 20 psi for the Utility to consider the connection request.

C. Drafting Standards

Required drafting standards are outlined in Appendix B-Water Distribution Plans and shall be followed by the Design Engineer for all drawings submitted to the Utility.

D. Surveying Requirements

The Design Engineer shall incorporate vertical and horizontal references in the design. Vertical control shall be based on Mean Sea Level (MSL) and horizontal control shall be in Indiana East State Plane Coordinates, North American Datum 1983 (NAD83). See Appendix B - Water Distribution Plans for digital registration requirements.

2.03 Layout Standards

Layout of the Utility facilities shall adhere to the following requirements:

A. Water Main Separation from Other Utilities

A minimum of 10' horizontal separation and 18" vertical separation between sewer lines (sanitary, storm, or combined sanitary/storm) and water main shall be designed in accordance with the Indiana Administrative Code, Title , 327IAC 8-3.2-9, <http://www.in.gov/legislative/iac/T03270/A00080.PDF>. Water main shall be a minimum of 3' from other utilities including Telcom, gas, electric, fiber optic. Installation of these facilities in proximity to one another shall only be allowed as shown in Standard Practice Drawing "A"- Water Main Separation from Other Utilities Detail. Water mains and sewer lines (sanitary or storm) and laterals shall never be constructed in the same trench. When crossing, the sewer and water shall cross at a minimum angle of forty-five (45) degrees as measured from the centerlines of the pipes. Sanitary sewer laterals shall conform to the specified separation requirements.

B. Water Mains

Preferred placement of water main installation is 4' behind the back of curb (or edge of pavement if no curbs are installed) in new developments. Should sidewalks be placed immediately behind the curb, the water mains shall be placed a minimum of 2' in back of the sidewalk. Where applicable, Utility prefers the water mains be placed in the grass strip between the sidewalk and curb.

Where applicable, water mains shall be installed parallel to the street, outside of the pavement limits, and no less than 5' inside the right-of-way line.

Along frontages of new developments and extension from existing water main to the frontage of a new development, water main must be located within a minimum 20' easement adjacent to the right-of-way

Refer to Standard Practice Drawing "H"-Typical Channel Crossing for details on all pipeline channel crossings.

Hydrants and valves shall be installed at property lines and/or street intersections as noted in Standard Practice Drawing "F"-Typical Valve Placement.

Standard pipe sizes are 3", 8", 12", 16", 20" and 24" diameter. The pipe sizes to be used throughout the proposed development shall be established by the Utility as

determined by hydraulic analysis and comparison to the Master Plan (see Section 2.02 B).

The maximum length of any 8" water main shall not exceed 1,500 feet in length on any dead-end. A proposed water main shall be considered a dead-end main if the proposed water main does not connect to an existing water main in the adjacent right-of-way in a minimum of two locations.

Dead-end water main extensions for non-residential customers shall be a minimum of 12" in diameter.

All 3" pipe shall be polyethylene (HDPE). Larger pipe shall be polyvinyl chloride (PVC), HDPE or ductile iron (DI). Pipe installed at stream crossings shall be HDPE or DI with restrained bends (see Section 7.0-Material Requirements for Water Main Installation and Standard Practice Drawing "H"-Typical Channel Crossing). Pipe installed in a casing pipe shall be either HDPE or restrained joint DI (see Section 7.0-Material Requirements for Water Main Installation and Standard Practice Drawing "I"-Typical Boring Casing Pipe).

Only 3" HDPE pipe shall wrap around cul-de-sacs (see Standard Practice Drawing "D"-Cul-de-Sac Water Main and Hydrant Installation and Standard Practice Drawing "E"-Cul-de-Sac Water Main with Hydrant at Intersection). Pipe layout shall be designed to avoid installation of private service lines under the ends of cul-de-sacs. Five (5) residential properties may receive water service from the 3" HDPE pipe or a maximum footage of 300' of 3" HDPE pipe. No valves or hydrants shall be placed on 3" HDPE pipe.

All proposed main extensions shall provide plan drawings with the proposed main alignment. A profile is required for mains 16" and larger. Mains smaller than 16" require a profile drawing if the grade elevation changes +/- 1'-0". Profile drawings are also required where a main crosses a railroad, stream and interstate. The profile shall include the existing and proposed grades over the proposed water main route. The grade of the public or private road/street centerline shall be shown where existing or proposed roadway surfaces parallel the water main.

Offset alignment and all proposed or existing utilities shall be shown on the plan and profile views.

C. Valves

Valves shall be placed at development entrances, cul-de-sacs, intersections, and hydrants (see Standard Practice Drawing "F"-Typical Valve Placement). If a valve is to be installed at or near a reducer, the placement shall be determined by the Utility.

The size of the main establishes the type of valve and the minimum spacing required between successive valves. The following chart indicates the type of valve and distance between valves to be used for each main size. Valves located within subdivisions may require closer spacing, as determined by the Utility, to allow for adequate isolation of mains.

| Pipe Size | Distance Between (max.) | Valve Type |
|------------------|--------------------------------|---|
| 6" through 12" | 1,000' - 1,200' | Gate or as approved by the Utility |
| 16" through 24" | 1,200' - 1,800' | Butterfly or as approved by the Utility |
| 30" or larger | Maximum 1,800' | Butterfly or as approved by the Utility |

D. Tapping Sleeves and Valves

Connections branching off of an existing water main will typically be constructed using a tapping sleeve (or saddle) and valve in order to minimize service disruptions to existing Utility customers. Submitted plans shall show a tee and valve at the point of connection with a note identifying the connection as a fabricated tap. Since the valve must be installed level, the design should account for the location of other underground facilities, tapping materials, and size of the tapping equipment.

E. Fittings (Tees, Crosses and Bends)

All fittings shall be standard sizes.

Bends shall be no greater than 45° for 8" diameter mains and no greater than 22.5° for 12" diameter mains and larger.

F. Reducers

Reducers shall be placed adjacent to tees or crosses and where larger pipe reduces to smaller pipe as determined by hydraulic modeling.

G. Fire Hydrants

Fire hydrant design, material and installation shall comply with all applicable local ordinances within the extended Utility service area. Fire hydrants within the Utility service area except for those used by Zionsville Fire Department shall be placed at intersections and property lines at a spacing of approximately 500', no closer than 400' and farther than 600'. For areas within the Utility service area served by Zionsville Fire Department, hydrants are required every 300'. If required, the local fire department shall review hydrant locations prior to plan submittal to the Utility.

A hydrant shall be placed within 150' of the back edge of the pavement of a cul-de-sac or court. (Refer to Standard Practice Drawing "D"-Cul-De-Sac Water Main and Hydrant Installation and Standard Practice Drawing "E"-Cul-De-Sac Water Main with Hydrant at Intersection). This requirement may necessitate smaller hydrant spacing within the proposed development than the maximum allowed by the Utility.

Hydrants shall be shown perpendicular to the water main, with the hydrant away from the street and placed between the water main and the sidewalk, where applicable. Hydrants shall have an auxiliary valve (see Standard Practice Drawing "B"-Standard Hydrant Setting for Citizens Water and Citizens Westfield). On the proposed project drawings, the Design Engineer shall use the appropriate symbol to show the hydrant with a valve and place the tee of the hydrant assembly on the main to which it will be connected. Note that the hydrant symbols in the design drawing are used to indicate the location of the hydrant tee. Actual placement of hydrants and branch valves shall be field determined to meet applicable installation standards.

H. Dead End Mains

For Citizens Water, blowoffs shall be installed on any 3-inch diameter dead end main. Blowoffs shall be installed on 8-inch diameter dead end mains less than 300 feet long. Hydrants shall be installed on 8-inch diameter dead end mains 300 feet or longer. For pipes greater than 8-inches in diameter, hydrants must be installed on any dead-end mains.

I. Plugs

Plugs shall be placed at the end of the proposed water main to create a watertight piping system. Kicker Block or Thrust Block should be inserted at the end of the main.

J. Blow-Off Assemblies

Blow-off assemblies shall be placed on the ends of mains which terminate at a property boundary. Blow-off assemblies shall be placed directly at the end of the main for 3", or 8" pipes (see Standard Practice Drawing "J"-2" Blow-Off Assembly for 3" and 8" Main). A kicker or thrust block should be shown at the end of the main on the proposed project drawings.

Blow-off assemblies on pipes greater than 8" shall have a tee with a 6" branch (see Standard Practice Drawing "K"- 2" Blow Assembly -Off for 12" through 24" Main). The blow-off shall be placed on the 6" branch and a plug shall be placed on the end run of the main line of the tee. The branch and blow-off assembly shall face away from the curb. A kicker block shall be placed behind the plug to prevent movement of the water main under pressure (see Standard Practice Drawings).

If a temporary blow-off assembly is to be installed and removed at a later date as development continues, the blow-off assembly shall be labeled as "Temporary B.O.". When the development is continued from that point, it should be indicated on the drawing by including the note "Remove Temporary B.O. and Return to CW." Blow-off assemblies that will remain in place as permanent flushing points shall be labeled as "B.O."

WESTFIELD – Temporary hydrants shall be utilized for blow-off assemblies.

K. Sample Station

Sampling stations shall be a 4' bury assembly with a 3/4" FIP inlet and a 3/4" hose or unthreaded nozzle. All stations shall be enclosed in a lockable, non-removable, aluminum-cast housing. When opened, the station shall require no key for operation. All working parts shall be of brass and removable from above ground with no digging. A poly vent tube shall be provided to enable each station to be pumped free of standing water to prevent freezing and to minimize bacteria growth. The exterior piping shall be galvanized (see Standard Practice Drawing "P"-Sampling Station Standard Arrangement). The Contractor/Developer shall install sample stations at the discretion of the Utility.

L. Air Relief

Air relief valves are required on all water mains 16" or larger. Air relief valves are required on water mains, regardless of size, when elevation changes are sufficient to cause air entrapment. In addition, profile drawings of water main designs will be required when air relief valves are warranted. Refer to Standard Practice Drawing "M"- 'Air Relief Apparatus for Water Mains'.

M. Variance Request

A variance request shall be submitted to request any deviation from the standards listed within the standards manual. The variance request form, attached in Appendix C, shall be used to request a variance. Any variances must be approved by the Utility.

2.04 Easement Requirements

A. Document Preparation

The Utility shall prepare the easement document and the Developer or Design Engineer shall provide the easement exhibits (with legal description and drawing) and last deed of record. The easement description and exhibits shall be prepared by a licensed Professional Land Surveyor registered in the State of Indiana.

The Developer or Design Engineer shall submit drawings as prepared by the Surveyor with the easement submittal. A digital layout of the tract of land shall be provided which delineates the proposed easement in addition to the last deed of record. The easement shall be laid out in compliance with the Utility's GIS system referencing the State Plane Coordinate system as defined in Appendix B – Water Distribution Plans.

B. Easements are required along all frontages of new developments for the benefit of Citizens future use. Frontages shall be covered as described within the Terms and Conditions

C. Minimum Requirements

1. Adjacent to a platted public right-of-way (R/W)

A minimum 20' wide utility easement directly adjacent to the right-of-way is required. The easement shall be adjacent to the right-of-way in order to allow the Utility access for future maintenance and repair of the facilities installed within the easement.

2. Adjacent to a private street

A minimum 30' wide utility easement directly adjacent to a permanent feature for example, the edge of pavement, back of curb, or sidewalk is required.

3. Undeveloped areas

In areas where no private or platted streets exist, the easement shall be a 30' wide non-exclusive easement. Provisions must allow the Utility access for future maintenance and repair of the facilities installed within the easement.

4. Special areas

Site conditions or facility requirements may require a departure from the standard easement requirements. The Utility shall notify the applicant.

END OF SECTION

SECTION 3.0 DESIGN AND LAYOUT STANDARDS FOR SERVICE LINES

3.01 General

In order to assist the Owner, Contractor/Plumber and the Design Engineer with the layout and design of the proposed service line, the following standards are provided.

3.02 Design Standards

These standards provide a minimum design guideline outlining the Utility’s requirements to assure the safe, reliable delivery of potable water to its customers.

A. Service Line

The following table (3.1) identifies service lines that require a design plan to be submitted to the Utility for review. An electronic submittal is required for all service sizes identified in the table, with the exception of residential fire services. Residential fire will require an electronic submittal for 2” line sizes or larger.

Table 3.1 Services Requiring Design Submittals

| CUSTOMER TYPE, SERVICE CLASS | DOMESTIC | FIRE | IRRIGATION |
|---|-----------------|--------------|-------------------|
| RESIDENTIAL | None Required | 2” or larger | All Sizes |
| COMMERCIAL | 1 ½” or larger | 2” or larger | All Sizes |
| INDUSTRIAL | 1 ½” or larger | 2” or larger | All Sizes |

B. Design Responsibility

The Utility requires that a registered Professional Engineer, licensed in the State of Indiana, design all service lines where drawings are required, in accordance with Table 3.1 – Services Requiring Design Submittals. The Design Engineer shall be responsible to ensure that the overall design of the proposed service line meets all Federal, State, and Local requirements and regulations.

The Utility’s review of the Design Engineer’s plans does not constitute engineering design, but rather verifies that the proposed facilities and submittals meet the minimum Utility standards.

C. Drafting Standards

The drafting standards are outlined in Appendix B-Water Distribution Plans and shall be followed by the Design Engineer for all drawings submitted to the Utility

D. Surveying Requirements

A site survey of the proposed project is required for all drawing submittals. The survey shall identify the existing and finished grade ground elevations and location such that the plans developed for the service lines can be inserted into the Utility’s GIS. The Utility’s GIS uses the State Plane Coordinate system with elevations

measured in feet as defined in Appendix B – Water Distribution Plans.

3.03 Layout Standards

Layout of the service line shall adhere to the following details for the listed items.

A. Service Line Separation from Other Utilities

A minimum of a 10' horizontal separation and an 18" vertical separation between sewer lines (sanitary or storm) and service line shall be designed per 327 IAC 8-3.2-9. Water service shall be a minimum of 3' from other utilities including Telcom, gas, electric, fiber optic. Installation of these facilities in proximity to one another shall only be allowed as shown in Standard Practice Drawing "A"- Water Main Separation from Other Utilities . Service lines and sewer lines (sanitary or storm) and laterals shall never be constructed in the same trench.

Sanitary sewer laterals and septic fields shall conform to the specified separation requirements.

B. Service Lines

Standard pipe sizes are: 3/4", 1", 1 1/4", 1 1/2", 2", 3", 4", 6", 8", 10", 12", and 16" diameter. Standard taps are: 3/4", 1", 2", 4", 6", 8", 12", and 16" diameter. Developer/Contractor shall provide fittings to reduce to a smaller service line size as required.

| POLY | PVC | DI |
|----------------------------|--------------|---------------|
| DR9 3/4"-2" DR11 3"-16" | C900 4" – 8" | C350 4" – 16" |

Services shall be sized according to requirement in Section 5.02. All services within a one (1) square mile surrounding the City of Indianapolis, Indiana, in close proximity to steam lines or petroleum transport lines shall be DI or copper. Particular attention shall be given to the Mile Square section of the City, the downtown area bounded by North, East, South and West Streets

Pipe installed at stream crossings shall be HDPE or DI with restrained bends and joints as specified in Section 7.0-Material Requirements for Water Main and Standard Practice Drawing "H-1"-Typical Channel Crossing.

2" service lines or smaller shall be a continuous pipe without joints or fittings. All PVC service lines shall not have any vertical or horizontal bends.

Service lines installed in a casing pipe shall be HDPE, restrained joint DI or restrained joint PVC. PVC and DI service lines installed in a casing shall be restrained at each joint within the casing as specified in Standard Practice Drawing "I"-Typical Boring Casing Pipe.

A service line must be installed a minimum of 5' from adjoining property line.

C. Valves

External valves shall be placed at the point of connection to the distribution system, the point of branching domestic, irrigation and fire lines outside, or inside where

applicable, the buildings served. Each private hydrant must have a control valve as specified in Standard Practice Drawing "F"-Typical Valve Placement. Fire line branch valve (or PIV) should be installed with domestic valve branched upstream of fire line branch valve. Standard drawing should be included in standard practice drawing section. If a wall mounted PIV is installed, a fire line branch valve must also be installed outside of the building.

D. Location of Fire Line Riser

A new fire line riser shall be turned up within 5' of the building penetration

E. Tapping Sleeves and Valves

Connections branching off of an existing Utility water main will typically be constructed using a tapping sleeve (or saddle) and valve owned and operated by the Utility in order to minimize service disruptions to existing Utility customers. Any additional required materials will be furnished by and at the expense of the customer.

Standard tap sizes are: ¾", 1", 1 ½", 2", 4", 6", 8", 10", and 12" diameter.

F. Irregular Tap

All taps shall be constructed on the service side of the main. Services shall be installed perpendicular to the main from the tap to the meter pit within the R/W. In the event the service cannot be installed in this manner, any variance must be approved by the Utility prior to installation.

G. Fire Hydrants

Hydrant location may be subject to approval of the local fire department and shall be reviewed prior to final plan submittal to the Utility. Each private hydrant shall have an isolation valve installed at the point of branching.

3.04 Irregular Services

- A. The Utility is not under any obligation to permit connection or supply service to any customer whose property does not abut a main. However, the Utility, in its judgment, can approve the installation of an irregular service line upon execution of an Association Agreement.
- B. An irregular service line will only be considered as an option for receiving service when all of the following conditions apply:
 - 1. The property does not abut a public water main.
 - 2. The property is an isolated premise that does not abut a public right-of-way.
 - 3. Adjacent subsequent properties cannot be served by a main extension.

3.05 Association Agreements

- A. The Utility may contract, in its judgment, with two (2) or more prospective customers for water service from one (1) primary service pipe, provided the customers have entered into a written contract with the Utility and with each

other to provide for the maintenance of the primary service pipe and all related branches and to pay all associated private fire service charges.

- B. A service line to an isolated premises shall not be installed across a property, lot or easement line to connect to a main until the prospective customer and the owner(s) of the adjacent land between the isolated premises and the main have entered into a written contract with the Utility and with each other to provide for the maintenance of the service pipe and to pay all associated private fire service charges.
- C. The Association Agreement shall include an easement exhibit and a written legal description of the service line easement by a Registered Land Surveyor. The easement exhibits shall be furnished by the customer requesting the irregular service line, along with the current deeds of record for the easement and the property receiving service. Upon review and approval of the easement exhibits, the Utility will prepare and deliver an Association Agreement for execution by the customer requesting the irregular service.
- D. The Utility will not approve any irregular service without an executed Association Agreement submitted with the application for service.

END OF SECTION

SECTION 4.0 PROJECT SUBMITTALS FOR WATER MAIN INSTALLATION

4.01 Purpose

This section establishes the required submittals and the sequence in which they should be submitted for approval by the Utility.

4.02 Required Drawing Submittal Medium

Submittals shall be made in digital format and uploaded to Citizens provided website. Refer to Appendix A for drawing requirements.

4.03 Submittals

The following submittals are required:

A. Phase 1-Project Initiation

During Phase 1, the information provided by the Developer or their Design Engineer is used by the Utility to perform critical hydraulic analyses of the proposed development and determine the required water main sizing.

1. Required Submittals- All items shall be submitted as a single package.

a. Overall Development Plan

The Overall Project Development Plan Checklist outlines the minimum requirements for the successful completion of this drawing.

b. Preliminary Water Main Design depicting the proposed fire hydrant locations

c. Preliminary Plat

Each Preliminary Plat shall cover only one (1) proposed section or phase of the overall proposed project development. Developer shall determine the extent of each section or phase.

The information provided in this submittal shall be used for further analyses, planning, establishing necessary easements and identifying unusual or "special" circumstances.

The Preliminary Plat Checklist outlines the minimum requirements for the successful completion of this drawing.

d. Preliminary Construction Plan

The Preliminary Construction Plan Checklist outlines the minimum requirements for the successful completion of this drawing

e. Hydraulic Analysis Design Data Form

Information provided in this submittal will be used for preliminary hydraulic analysis and planning of accurate water needs and demands. The Hydraulic Analysis Design Data must be completed in its entirety for the Utility to perform accurate hydraulic modeling.

f. Drawing Submittal Data

The information provided by the Design Engineer on the Drawing Submittal Form will be used to identify the digital parameters used in the drawings so that a one-to-one conversion to the Utility GIS can be established (especially for Design Engineers using CAD programs other than AutoCAD).

B. Phase 2 – Final Design Review

Submittals during Phase 2 shall comply with all requirements of these Standards, i.e. designed layout, easements, etc., before the project will be released for construction.

1. All items shall be submitted as a single package.

a. Final Construction Plan

The Final Construction Plan Checklist itemizes the minimum requirements for the successful completion of this drawing. The paper copy of this drawing shall have the Design Engineer's stamp and dated signature.

b. Situation Plan

The Situation Plan is a smaller and less detailed plan of the proposed project. This plan is used by the Utility to locate and identify major components of the water main for future planning. The Situation Plan must be 8-1/2" x 11" or 11" x 17" and at a 1" = 200' scale. It shall include a north arrow, a project information block, a project location map, existing water main information, a typical street cross section, the project boundary, the proposed roads and right-of-way dimensions, all job number information blocks, and the proposed water infrastructure.

c. Easement Exhibits

The Easement Exhibits and last deed of record shall be submitted by the Developer or their Design Engineer for final review by the Utility to ensure that all water mains are placed in appropriate easement locations. CW will record the easement, but it is the sole responsibility of the developer to notarize the appropriate documents prior to submitting. The Easement Exhibit Checklist itemizes the minimum requirements of a drawing.

d. Plat Map

Each Plat Map shall cover only one (1) proposed section or phase of the overall proposed project development. The Plat Map submittal does not need to be the recorded plat but shall be suitable for recording. No seal or signature is required on this map.

Information provided in this submittal will be used to ensure necessary easements under normal and "special" circumstances.

The Plat Map Checklist itemizes the minimum requirements of a drawing.

e. Additional Submittals Required

The following items shall be completed and returned to the Utility prior to commencement of any construction:

- i. Main Extension Agreement/Contract
- ii. Certificate of Insurance (obtained by Developer and Contractor from an insurance agency). The Utility shall be named as an additional insured on the form submitted.
- iii. The completed Notice of Intent (NOI) shall be submitted with all other final plan submittals from the Design Engineer. The NOI shall be complete, signed by the Professional Engineer and Developer, and ready for signing by the Utility.

C. Phase 3 - Project Construction

Appendix C - Construction Testing Methods specifies the procedures including disinfection, sampling, hydrostatic testing, flushing and bacteriological testing a Developer/Contractor shall follow to complete testing of the project.

D. Phase 4 - Project Placement In-Service

The project receivables shall provide accurate information regarding the exact location and required specifications for all piping, fittings, valves, hydrants, blow-off assemblies, air relief valves, and associated appurtenances.

"Record drawings" and project receivables shall be received within two (2) weeks of the project's final connection to existing Utility's facilities. Connections for new services will not be allowed until the final connection is completed by the Developer and project receivables are submitted and approved.

1. Required Submittals

- a. "Record drawing" Construction Plan
The Record Drawing Checklist itemizes the minimum requirements for the successful completion of this drawing.
- b. Project Receivables

The following receivables shall be submitted, received and approved by the Utility.

- i. Final Actual Cost Form
- ii. Summary Cost Form (Commercial)
- iii. Contractor Release of Liens
- iv. Subcontractors/Suppliers Releases of Liens
- v. Maintenance and Repair Bond
- vi. Transfer of Ownership
- vii. Record Drawing Plan of Water Main
- viii. Plat Map (as submitted for recording)
- ix. Datalogger Results (if polyethylene was fused on project)
- x. Bore Profile for polyethylene installed pipe

4.04 Dry Main Installation Requests

All requests for dry main installations shall be submitted on a Request for Dry Main Installation form including the reason for the installation of a dry main. Requests will only be considered if plans for the project have been approved by the Utility. (See Section 9.23 for Installation Applications)

END OF SECTION

SECTION 5.0 APPLICATION FOR SERVICE LINES

5.01 Purpose

This section outlines the requirements for a domestic, irrigation and fire protection service application from the Owner, Developer, Contractor or Engineer. The application shall be filed with the Utility by a bonded plumber.

5.02 General

A Citizens Water Application for Plumbing Permit (commonly referred to as a Plumber's Permit Application) shall be submitted for each new service line (domestic, irrigation and fire) and any modification of service line. Approval by the Utility must be obtained prior to installation or modification of a service line (written approval from the Utility is required on all service lines 1 1/2" and larger). All work performed on a service line shall be performed by a plumber bonded with the Utility. All service line installations shall commence within 90 days of the approval date for service by the Utility. Any service line where installation has not commenced within 90 days after Utility approval shall be re-submitted for approval by the Utility.

An application for service shall provide complete information before a permit will be approved by the Utility. If this cannot be accomplished on the face of the application, a drawing shall be submitted with the application with reference measurements to buildings, lots and streets. Table 3.1 identifies service lines that require a drawing to be submitted with the application for service.

All requests for new service shall have a tract survey, legal description or lot number, and subdivision name attached to or included with the application for service.

Applications with missing information will not be approved and will be returned to the party that originally submitted the application. The work shall not commence until the permit application has been approved by the Utility.

A permit approved by the Utility approval is required for any modification, repair or replacement. See Water Service Application on the Citizens Energy Group website.

The service line shall be replaced in accordance with the Standards. Installation or replacement of a service line within an existing property shall require installation or relocation of the meter and/or backflow prevention device to meet current Utility Standards as specified in Section 6.0 - Plumber's Information and a Plumber's Permit Application.

All service lines requiring a bore shall have the service line installed up to the main before the tap is performed.

If the service line installation is not approved by the Utility, the Utility will mark the service line with a red tag indicating why service line installation was not approved or the tap performed.

Minimum size of service pipe shall be as follows:

- A. Domestic:
 - 1. 3/4" for homes under 2,000 sf and no irrigation
 - 2. 1" for homes over 2,000 sf or under 2,000 sf with irrigation

Each domestic service shall require an individual tap. Branched services are no longer acceptable.

- B. Irrigation: 1"
- C. Fire: 2"

Applicant must review and follow the plumbing code to confirm service line will support proposed fixtures. See CW Standard Practice Drawing T.

Any modification or replacement requires a Citizens approved permit.

5.03 Domestic Service

Residential – A meter will be set at the time of the inspection by the Utility for all taps for residential $\frac{3}{4}$ " and 1" service lines. Any unmetered private service line serving a single project with multiple buildings (e.g., a condominium development), shall submit a plot plan showing streets, lot numbers, and individual service lines $\frac{3}{4}$ " through 1 $\frac{1}{4}$ ". Services meeting this description do not require inspection by the Utility from the meter pit to the structure receiving service. However, the service line from the main to the meter pit will be inspected at the time of the scheduled tap and shall be approved by the Utility before the tap is made. Any domestic service line 1 $\frac{1}{2}$ " or larger shall be inspected from the main to the structure receiving service and shall be approved before the tap is made. A reduced pressure zone (RPZ) backflow preventer is required for commercial and industrial domestic services.

5.04 Fire Protection Service

For additional information, refer to the Fire Protection Checklist.

- A. Direct Pressure Fire Service requires the following:
 - 1. Application for Plumbing Permit.
 - 2. Three (3) full site utility plans approved by a Professional Engineer licensed in the State of Indiana.
 - 3. Plan shall show piping design including all fittings, valves, piping, metering, backflow prevention, hydrants and appurtenances.
 - 4. Plan shall include platted legal boundaries of property.
- B. Fire Protection Services with a Fire Pump requires the following:
 - 1. Application for Plumbing Permit.
 - 2. Three (3) full site utility plans approved by a Professional Engineer licensed in the State of Indiana.
 - 3. Plan shall show piping design, including all fittings, valves, piping, metering, backflow prevention, hydrants and appurtenances.
 - 4. Plan shall include platted legal boundaries of property.
 - 5. By-pass around fire pump.

6. Low suction control valve or cut-off valve with a 20-psi minimum setpoint.
7. Fire pump information (capacity and pump curves).
8. Backflow prevention device. An RPZ may be required if system includes gas- or diesel-powered pumps or glycol for freeze prevention.
9. Jockey pump information.
10. Utility Jockey pump meter.
11. Fire pump controller (kill switch).
12. Jockey pump controller (kill switch).

5.05 Requirements for New Irrigation Systems

A. Backflow Protection

The water line connecting the public water supply to any lawn irrigation system must be constructed with an air gap or include a reduced pressure principal backflow preventer or pressure type vacuum breaker in accordance with 327 IAC 8-10-6.

The air gap, reduced pressure principal backflow preventer or pressure type vacuum breaker must be constructed or installed in accordance with the requirements of Rule 327 IAC 8-10-7.

Customers are required to notify Citizens Energy Group of installation of an irrigation system and the need for backflow protection. This notification may be made by submittal of a Plumbers Permit Application if an application is required per Section 5.02 of this Standard. If a Plumbers Permit Application is not required, such as for installation of an irrigation system that is branched off of a domestic service, notification may be made by phone to the Utility's Customer Service.

B. Water Conservation

Irrigation systems shall be designed to ensure the system has the ability to provide adequate and efficient irrigation applications while (1) minimizing water consumption; and (2) preventing overwatering, standing water, runoff, off-target irrigation, and overspray across or onto a street, driveway, sidewalk, parking area, building, fence, impervious surface, non-landscaped area or adjoining property. To achieve these goals the irrigation system should be design and installed in accordance with the following:

1. Irrigation systems should use automatic controllers. Manually controlled permanently installed irrigation systems should not be used. Automatic controllers should include one or more of the following water conservation features:
 - a. Rain sensor that automatically shuts off the irrigation system during rain events.
 - b. Soil moisture sensor that interfaces with the automatic controller to reduce or shut off irrigation cycles based on soil moisture content.
 - c. U.S. EPA WaterSense-labeled Weather-Based Smart Controllers that control the irrigation cycles based on climatological and evapotranspiration data.

2. Systems should use high efficiency sprinkler nozzles with pressure regulation and check valves as required to ensure that the sprinkler nozzle operates in the pressure range recommended by the manufacturer.
3. Sprinkler nozzle locations and spray patterns should direct flow to avoid overspray onto hardscape surfaces.
4. Drip-type nozzles should be used in non-turf irrigation areas and in turf areas narrower than 48-inches.
5. Irrigation system should be designed to avoid ponding and runoff.

C. Additional Requirements for Non-Residential Irrigation Systems

At least fifteen (15) days prior to construction or installation of any Irrigation System, the customer shall submit to the Utility for recordkeeping purposes a completed Plumbing Permit Application, including information concerning the proposed construction or installation of any Irrigation System using the Utility's approved application form. Application forms are available from the Utility at <https://www.citizensenergygroup.com/For-Partners/Contractors-Builders/Permits-and-Forms>

Prior to submission of any application to the Utility, customer shall have identified and received in writing all required federal, state, and local governmental approvals, and attach true and complete copies of such approvals to the application.

Also, each application shall include the following information:

1. A general explanation of the proposed project.
2. A map of the location of the proposed project showing the legal boundaries of the property proposed to be irrigated, any easements associated with the property to be irrigated, scale, north arrow, and a delineation of the irrigated and non-irrigated areas.
3. Drawings of the proposed Irrigation System which shall identify, at a minimum:
 - a. The location of the proposed tap to the Utility's distribution system.
 - b. The location of the proposed backflow prevention device.
 - c. The location of the Irrigation System components, including sprinkler heads, check valves, pressure regulators, moisture sensing devices, and controllers.
 - d. The location of all system piping; and
 - e. The identification of the Irrigation System designer and contractor.
4. Any other information the Utility either requests from the customer or the customer believes will be useful to the Utility in reviewing the application for the Plumbing Permit.
5. The Utility may waive the submission of any information requested within Section 5.05(C).

D. Subdivision Common Area Exception

A separate service tap is required for each parcel provided with irrigation (or other service) and no lines shall cross the public right-of-way. However, an exception to this requirement will be allowed for irrigation systems serving subdivision common areas that contain multiple parcels, based on the submittal and approval of the design information specified in Section 5.05C of this standard. Lines that cross between adjacent parcels or the public right-of-way shall be minimized as in Standard Practice Drawing AA. The customer will be responsible for maintenance of any lines installed in the public right of way under this exception.

E. Certified Irrigation Designers & Contractors for Non-Residential Irrigation Systems

Beginning May 1, 2013, new non-residential irrigation systems shall be designed by a professional certified by the Irrigation Association. A copy of the certified design must be onsite at all times during construction of the irrigation system. Any modifications to the design conducted during installation must be noted by redline on the prints maintained onsite and supplied to the owner upon completion of installation. Modifications to the certified design cannot be in conflict with these Standards. A list of certified irrigation designers ("CIDs") and certified irrigation contractors ("CICs") can be obtained at www.irrigation.org or www.epa.gov/watersense.

F. Irrigation System Inspections

To ensure that irrigation systems are operated efficiently and effectively, the Utility recommends that all irrigation systems are inspected annually. The inspection should consist of operating each zone of the irrigation system and verifying that there are no broken or damaged components, that spray patterns are uniformly applying water over landscaped areas as designed, that irrigation of hardscape areas is avoided, and that there is no rapid ponding or puddle development. Any deficiencies identified during the annual inspection should be resolved to ensure efficient irrigation system operations. The Utility recommends the use of a certified landscape irrigation auditor (CLIA) for conducting the annual inspection for system with service line sizes of 1-1/2 inch or larger. A list of certified landscape irrigation auditors (CLIA) can be obtained at www.irrigation.org or www.epa.gov/watersense

G. Metered Service for Irrigation Systems

All Irrigation Systems provided water service by Utility shall be metered in accordance with the Utility's rules and regulations on file with the Indiana Utility Regulatory Commission (IURC) and per Citizens Energy Group Water Standards Manual.

H. Utility's Reservation of Rights

The Utility reserves the right to inspect all Irrigation Systems. If any component of the Irrigation System is found not to be designed, installed, or operated in accordance with the submitted application, this Standard, or the manufacturer's instructions, and such deficiency is not corrected within thirty (30) days of customer's receipt of written notice of such deficiency, the Utility has the right, consistent with the terms of the application, to disconnect the Irrigation System from the Utility's water distribution system at the customer's expense.

WESTFIELD – Additionally, refer to Irrigation System Connection Detail T.WF5.

- I. Disconnecting Existing Irrigation Systems
 - a. If an existing irrigation system is no longer desired (temporarily or permanently), it must be cut and capped at the point of branch. The backflow prevention device and branch valve on any irrigation line must be removed. The irrigation line should be cut and capped as follows:
 - i. Combination lines must be cut and capped at the point of branch (typically in the water meter pit).
 - ii. Irrigation line that originates inside a structure must be cut and capped at branch point.
 - iii. Dedicated irrigation lines must be cut and capped at the backflow prevention device.

Any other irrigation cut and cap scenarios will be evaluated on a case-by-case basis by the Utility. Please refer to drawing T.5 in the Citizens Water Standard Practice Drawing section

END OF SECTION

SECTION 6.0 PLUMBER'S INFORMATION

6.01 Purpose

The intent of this section is to provide direction to the Plumber/Contractor with the installation of new service lines or modification(s) to existing service lines.

WESTFIELD – Plumbers shall follow and be subject to the “Water Service Tariff Rates, Terms and Conditions for Water Service within Westfield, Indiana.”

For more information regarding Westfield Plumber's Information please refer to the following websites-

<https://www.citizensenergygroup.com/For-Partners/Contractors-Builders/Permits-and-Forms>

<https://www.citizensenergygroup.com/My-Home/Rates-Regulatory-Notices?option=b>

6.02 Conformance to Standards

The Plumber/Contractor shall conform to these Standards and the Utility approved plans.

6.03 Application for Service

Application shall be made in accordance with Section 5.0

6.04 Bond

Each Plumber/Contractor shall post a \$25,000 maintenance bond for all service line projects (for additional information, refer to Application for Plumber's Permit). The maintenance bond shall cover the failure of the Plumber/Contractor to correct faulty workmanship or for damage to the Utility system and/or facilities due to actions by the Plumber/Contractor.

6.05 Maintenance of Service Line

The Plumber/Contractor shall be responsible for the repair and maintenance of all service lines installed, repaired or replaced due to improper workmanship or faulty materials for a period of three (3) years from the date of connection to the Utility's distribution system or date of last work performed. A performance bond shall be in full force and effect, in the name of the Utility, for a three (3) year period, extending from the last date work was performed. After the three (3) year period, the Owner is then responsible for service line repairs on the property served or if a resizing of the service line is required.

END OF SECTION

SECTION 7.0 MATERIAL REQUIREMENTS FOR WATER MAINS

7.01 General

The Developer and/or Contractor shall furnish all pipeline materials necessary for the complete installation and associated construction of all Developer installed water mains and appurtenances. All materials shall be new or in a condition that complies with the Standards. All materials shall be suitable for installation especially when depth of bury exceeds 9 feet.

The Utility shall review and consider changes to the material type and suppliers and manufacturers on an as needed basis. All materials shall be tested and verified that they meet all applicable American Water Works Association (AWWA), American National Standards Institute (ANSI), American Society of Testing and Materials (ASTM), Underwriters Laboratories (U/L) and National Sanitation Foundation (NSF) Standards, as well as all applicable Local, State and Federal laws.

7.02 Polyvinyl Chloride (PVC) Pipe (6" and 8" Diameter)

All PVC pipe shall be of a blue tint and conform to the latest edition of ANSI/AWWA C900. The pipe shall have the same outside diameter as ductile iron pipe. Materials from which the pipe was manufactured shall have been tested and approved for conveying potable water by the NSF and U/L. All PVC pipes shall be marked with the U/L logo. Where fittings are required, DI fittings shall be used (refer to Section 7.03 - Ductile Iron Pipe and Fittings", Subpart B-D & F, Joints).

A. Wall Thickness, Small Pipe

Pipe wall thickness for 6" and 8" pipe shall be as required to provide a minimum wall thickness of DR 18 for Pressure Class 150, as defined by ANSI/AWWA C900.

B. Joints

Joints for PVC pipe shall be slip-on type with integral bell and spigot. Gasket lubricant shall be as specified by the pipe manufacturer.

C Use of PVC 12" and larger shall require approval by the Utility.

7.03 Ductile Iron Pipe and Fittings

A. Ductile Iron (DI) Pipe

1. Unless indicated otherwise on the construction plans, all 8" through 36" diameter pipe shall be Class 350; complete with all accessories specified in Section 7.03 Ductile Iron Pipe and Fittings and conforming to ANSI/AWWA C151/A21.51 with polyethylene encasement per Section 7.15, "Polyethylene Encasement". The joint shall be of the push joint (PJ) type conforming to ANSI/AWWA C111/A21.11. Gaskets shall be Tyton Type and conform to ANSI/AWWA C111/A21.11. Gasket lubricant shall conform to ANSI/AWWA C111/A21.11. The pipe shall be cement mortar lined in accordance with ANSI/AWWA C104/A21.4 and shall be coated outside with a bituminous coating.
2. For restrained pipe, the locking segment slots shall be integral with the pipe bell. The working pressure of the restrained joint shall match the pipe. The number of locking segments and rubber retainers shall be as follows:

| Pipe Diameter | Number of Locking Segments | Number of Rubber Retainers |
|---------------|----------------------------|----------------------------|
| 4"-10" | 2 | 1 |
| 12"-20" | 4 | 2 |
| 24"-36" | 8 | 4 |

B. Ductile Iron Fittings

Ductile iron fittings shall be complete with all accessories (refer to Section 7.03.D) and shall conform to ANSI/AWWA C110/A21.10, 350 psi pressure rating requirements.

All fittings shall be cement mortar lined conforming to ANSI/AWWA C104/A21.4 and shall be coated outside with a bituminous coating or fusion-bonded epoxy.

Fittings shall have distinctly cast into the pipe exterior the pressure rating and letters "DI" or "DUCTILE". All DI fittings acceptable to the Utility shall be rated at a minimum of 70-50-05 (ksi tensile strength-ksi yield strength-percent elongation), in accordance with ANSI/AWWA C110 standards regarding strength of materials.

Fitting joints shall be of the standard mechanical joint (MJ) type conforming to ANSI/AWWA C111/A21.11 or push joint (PJ) type conforming to ANSI/AWWA C111/A21.11.

All T-head bolts shall be in accordance with AWWA C111/A21.11 and anti-corrosion type (blue bolt) by manufacturers such as Xylan or FluoroKote #1.

C. Compact Ductile Iron Fittings

Lightweight DI, MJ, or PJ type fittings shall conform to ANSI/AWWA C153/A21.53 and may be used at the Contractor's option. Fitting wall thickness shall meet or exceed ductile iron Class 53 and shall have a working pressure rating of 350 psi.

All fittings shall be cement mortar lined conforming to ANSI/AWWA C104/A21.4 and shall be coated outside with a bituminous or fusion bounded epoxy coating.

All T-head bolts shall be in accordance with AWWA C111/A21.11 and anti-corrosion type (blue bolt) by manufacturers such as Xylan or FluoroKote #1.

D. Mechanical Joint Fitting Accessories

MJ fitting accessories shall consist of gaskets, glands and T-head bolts with nuts. MJ fitting accessories shall conform to ANSI/AWWA C111 A21.11. The T-head bolts shall be anti-corrosion type (blue bolt) by manufacturers such as Xylan or FluoroKote #1.

E. Special Gasket Material for Ductile Iron Pipe

In construction areas where contaminated soils exist or existing steam utility lines are installed, ductile iron pipe shall be required for installation with Viton gaskets in the pipe as approved by the Utility. Gasket lubricant shall be as specified by the pipe manufacturer.

7.04 Polyethylene (HDPE) Pipe and Fittings (3" through 36" Diameter)

A. Polyethylene Pipe

Polyethylene pipe shall conform to ANSI/AWWA C901 and ANSI/AWWA C906. Material used in the manufacture of HDPE pipe shall conform to the PE Standard Code PE 3408. All HDPE pipes shall have the same outside diameter as DI pipe except for 3" pipe, where iron pipe size shall be used.

All distribution network HDPE pipe shall have a blue shell or a minimum of six (6) longitudinal blue stripes, the AWWA specification stamp embedment or permanent blue-line print.

All well line HDPE pipe shall have a purple shell or a minimum of six (6) longitudinal purple stripes, the AWWA specification stamp embedment or permanent purple-line print.

B. Wall Thickness

Distribution network piping minimum pipe wall thickness shall be Standard Dimension Ratio (SDR) 11 for pipe 3" through 36" in diameter.

Well line piping shall be a minimum of SDR 17 or as required by the design and approved by the Utility.

C. Polyethylene Fittings

HDPE fittings shall utilize the same DR as the pipe being installed.

D. Polyethylene Mechanical Joint Adapters for use on Polyethylene Pipe

All polyethylene mechanical joint adapters:

1. Shall consist of one (1) piece construction from solid billet polyethylene.
2. Shall include a stainless-steel integrated stiffener for sizes 16" through 36" (do not have to include stainless steel stiffener on sizes 6" through 12").
3. Shall utilize the same DR as the pipe being installed and ductile iron pipe size (DIPS)
4. Shall be of ductile iron pipe outside diameter.
5. Shall allow sufficient clearance for full swing of butterfly valve action of disc.
6. Shall include complete mechanical joint (MJ) accessory kit including:
 - a. C110 full body, MJ heavy gland or machined steel gland of equal thickness.
 - b. Sufficient number and length MJ T-head bolts and nuts. T-head bolts shall be in accordance with AWWA C111/A21.11 and anti-corrosion type (blue bolt) by manufacturers such as Xylan or FluoroKote #1.
 - c. Standard MJ gasket.

7.05 Valves

Gate Valves

- A. See Table 7.05.1 below for opening orientation by Territory Area
- B. Manufacturer(s) (Model) American Flow Control

Tapping Valves

- A. See Table 7.05.1 below for opening orientation by Territory Area
- B. Manufacturer(s) (Model) American Flow Control

Butterfly Valves

- A. See Table 7.05.1 below for opening orientation by Territory Area
- B. Manufacturer(s) (Model): Pratt HP250 or Val-Matic

Super Valve

For valves requiring remote operation, please contact the Plant Engineering group to discuss requirements.

Table 7.1 Valve Opening Orientation

| | CW Territory | | | | | Plant |
|-------------------|-----------------------------------|------------------------|------------------------|------------------------------|------------------------------|------------------------------|
| | Marion County & Surrounding Areas | Noblesville | East Morgan County | Southern Madison | Westfield | |
| Valve Orientation | Open Right (Clockwise) | Open Right (Clockwise) | Open Right (Clockwise) | Open Left (Counterclockwise) | Open Left (Counterclockwise) | Open Left (Counterclockwise) |

7.06 Tapping Sleeves

- A. Tapping Sleeves (Stainless Steel)
 1. All taps on PVC, ductile iron, and cast-iron pipe (unless size on size) shall utilize stainless steel tapping sleeves. For size-on-size applications, the installation of an MJ Tee shall be required.
 2. The sleeve body shall be manufactured entirely of stainless steel for total corrosion control. All welds shall be fully passivated to restore stainless characteristics.
 3. The gasket shall be gridded, virgin GPR compounded for water service. The gasket shall be of SBR per ASTM D 2000 MBA710 glued into the face of the flange. The full gasket shall give 360 degrees pipe coverage.
 4. The flange shall conform to ANSI/AWWA C207 Class D, 150 lb. drilling. The flange shall be stainless steel with recess to accept standard tapping valves.
 5. The bolts and nuts shall be stainless steel with non-corrosive (NC) threads. The hex nuts shall be fluorocarbon coated with plastic lubricating washers.
 6. Flanged joint fitting accessories shall consist of 1/8" thick gaskets and stainless-steel bolts with nuts. Flange joint gaskets shall conform to ANSI/AWWA C111/A21.11. All stainless-steel bolts, nuts and washers

connecting the tapping valve flange face to the tapping sleeve flange face shall be ANSI Type 304 or 316 stainless steel.

7. A hydrostatic test of 150 PSI or 1.5 times the working pressure if it exceeds 100 PSI for a minimum of 15 minutes shall be performed between the sleeve and valve before tapping pipe.
8. All tapping sleeves and metallic pipe are to be wrapped with polyethylene encasement as specified in Section 7.15, "Polyethylene Encasement".

B. Accepted Manufacturer(s) and Models

1. Up to 12" diameter mains: Ford Meter Box Company, Inc. (FAST), JCM Industries (Model 432), or Smith Blair (Model 663)
2. 16" through 24" diameter mains: Ford Meter Box Company (FTSS)
3. 30" diameter mains and larger: JCM Industries (Model 452)
4. Or Citizens approved equal

7.07 Hydrants

A. Specifications

Table 7.07.1 Fire Hydrant Specifications

| | Citizens Water Territory | | | | | |
|---|---|------------------------|--|------------------------------|------------------------------|--|
| | Marion County & Surrounding Areas | Noblesville | East Morgan County | Southern Madison | Westfield | Brownsburg |
| Operating Threads | Isolated from Potentially Corrosive Environments and lubricated with Food Grade Lubricant | | | | | |
| Operating Nuts | National Standard Pentagon | | | | | |
| Hydrant Orientation | Open Right (Clockwise) | Open Right (Clockwise) | Open Right (Clockwise) | Open Left (Counterclockwise) | Open Left (Counterclockwise) | Open Right (Clockwise) |
| Valve Opening | 5-1/4" | | | | | |
| Steamer Nozzle* | 4-1/2" ID x 5.375" OD x 6 threads per inch | Storz | 4-1/2" ID x 5.375" OD x 6 threads per inch | Storz | Storz | Storz |
| Hose Nozzles | (2) 2-1/2" (7-1/2 National Standard Threads per Inch) | | | | | |
| Steamer Nozzle | (1) 4-1/2" ^A | | | | | |
| Nozzles | Screwed or Locked into Upper Section, Sealed with O-Ring, & a pin or screw to prevent backing out | | | | | |
| Upper Valve Plate | Bronze | | | | | |
| Main Valve Seat | Bronze to Bronze Threads | | | | | |
| Mechanical Stop | Yes | | | | | |
| Weep/Drain Holes | Yes | | | | | |
| Epoxy Coat | Lower Valve plate & Interior Parts of Hydrant Shoe | | | | | |
| Bury Depth | 5' Bury Depth on all Mains 12" and Smaller 6' Bury Depth on all Mains 16" and Larger | | | | | |
| Barrel Extensions | No, Unless Approved by the Utility | | | | | |
| Lower Barrel | Ductile Iron | | | | | |
| Tracing Wire Connection | Yes Copperhead Test Station Trace Wire Loop or approved equal | | | | | |
| Approved Utility Hydrant Color (30 Mil Thickness) ^B | Sea Green w/ Reflective White Paint on Bonnet Flange ^C | Safety Yellow | Standard Red | Silver | Standard Red | Sea Green w/ Reflective White Paint on Bonnet Flange |
| Approved Private Hydrant Color^D | Standard Red or Safety Yellow | | | | | |
| Hydrant Cap Chains | Remove from Hydrant | | | | | |

^A Per Municipal or Fire Department Requirements

^A Storz Steamer Nozzles are required for hydrants located in Boone, Hamilton, Hancock (except for Buck Creek Township), Hendricks (except for the Town of Avon) and Shelby Counties

^B Color provided must be applied by the factory prior to installation and to be utilized for hydrant re-painting when necessary following installation.

^C White painted streamer caps are required for hydrants connected to 12" diameter mains and larger in **Marion County**.

^D Upon Final Approval by the Utility

B. Manufacturer(s) (Model)- American Flow Control

7.08 Valve Box, Lid and Riser

A. Cast Iron Valve Box and Lid

Special Utility CI valve box and lid shall be installed for each valve and blow-off assembly with a plastic riser, as specified in Standard Practice Drawing "G" - Standard 8" Valve Box and Cover.

WESTFIELD – CI, 2-piece, valve box per ASTM A48, Class 30B with "Water" embossed on CI lid.

B. Valve Box Riser

A solid ribbed 8" diameter PVC riser shall be required and shall be centered over the valve. If the valve is 6' deep or greater, a valve nut extension shall be installed to bring the operating nut to a depth 4' below finished grade.

WESTFIELD – 5 1/4" diameter screw type shafts.

C. Manufacturer(s) (Model) or CEG Approved Equal

Star Pipe Products (8" – VBIWCT (Frame) and VBIWCLID (Lid)) Sigma Corporation (5-1/4" - VB-2684B (Frame) and VB-2684L (Lid))

WESTFIELD-Star Pipe Products (5-1/4" – VB564S (Full Body), VBLIDW (Lid)

7.09 Blow-off Assembly (3" through 24" Water Mains)

A. The blow-off assembly (refer to Standard Practice Drawing "J"-2" Blow-Off Assembly for 3" through 8" Main and Standard Practice Drawing "K"-2" Blow-Off Assembly for 12", 16", 20", and 24" Main) shall be of an automatic freeze-proof design with a drain/weep hole drilled within a 2" ball valve.

B. Westfield – Shall utilize temporary hydrants as blow-offs.

C. Cul-de-sac: Blow-off shall be allowed if the distance is less than 300' of 3" pipe. All other applications shall require flushing hydrants.

D. Manufacturer(s) (Model) or CEG Approved Equal

1. Gil Industries

E. Valve shall be 600-lb. WOG bronze body with chrome plated brass ball with Teflon seals and stainless-steel bolts.

7.10 Blow-off Assembly (30" and Larger Water Mains)

A. As specified in the Utility approved project construction detail drawing.

WESTFIELD – Shall utilize temporary hydrants as blow-offs.

B. Manufacturer(s) (Model) or CEG Approved Equal

1. Main sizes above 24" will be determined during preliminary design

7.11 Air Relief Valves (16" and Larger Diameter Water Mains)

- A. Details and requirements of these fabricated assemblies are specified in Standard Practice Drawing "M" -Air Relief Apparatus for Water Mains.
- B. All air relief valves shall have cast iron bodies with stainless steel floats.
- C. Manufacturer(s) (Model) or CEG Approved Equal
 - 1. Valmatic Model 15A.3SV

7.12 Mechanical Joint Restraint Devices

- A. Joint restraint devices shall be used at all bends and fittings as well as thrust blocks (for spacing requirements refer to Standard Practice Drawing "O" - Installation of Restraints). Joint ends shall be PJ type or MJ. T-head bolts shall be in accordance with AWWA C111/A21.11 and anti-corrosion type (blue bolt) by manufacturers such as Xylan or FluoroKote #1.
- B. Manufacturer(s) (Model) or CEG Approved Equal
 - 1. EBAA IRON
 - 2. Ford Meter Box Company, Inc.

7.13 Ductile Iron Bell Joint Restraint Devices

- A. Ductile Iron Bell Joint restraint devices shall be used at bell and spigot joints and shall consist of one (1) wedge actuated restraint and (1) split ductile iron ring for new pipe and per one (1) split wedge actuated restraint and (1) split ductile iron ring for existing pipe. T-head bolts shall be in accordance with AWWA C111/A21.11 and anti-corrosion type (blue bolt) by manufacturers such as Xylan or FluoroKote #1. Refer to Standard Practice Drawing "O" -Installation of Restraints for location requirements.
- B. Manufacturer(s) (Model) or CEG Approved Equal
 - 1. EBAA IRON (1700 Series – for new pipe; 1100HD – for existing pipe)
 - 2. Ford Meter Box Company, Inc. (Series 1455 – for new pipe; Series 1490 – for existing pipe)

7.14 PVC Bell Joint Restraint Devices

- A. PVC Bell Joint restraint devices shall be used at bell and spigot joints and shall consist of two (2) split, serrated restrainers. T-head bolts shall be in accordance with AWWA C111/A21.11 and anti-corrosion type (blue bolt) by manufacturers such as Xylan or FluoroKote #1. Refer to Standard Practice Drawing "O" -Installation of Restraints for location requirements.
- B. Manufacturer(s) (Model) or CEG Approved Equal
 - 1. EBAA IRON (1900 Series)
 - 2. Star (1100 Series)
 - 3. Ford Meter Box Company, Inc. (1390 Series)

7.15 Polyethylene Encasement

A. Cross-Laminated Polyethylene Encasement

High density cross-laminated polyethylene encasement materials shall be used for ductile iron pipe and fittings. The high-density cross-laminated polyethylene tube material shall conform to ANSI/AWWA C105 with a minimum thickness of 4 mils.

B. Tube Diameter

The minimum tube size for each pipe diameter shall be as follows:

| Nominal Diameter | Polyethylene Flat Tube Width |
|------------------|------------------------------|
| 3" – 8" | 20" |
| 12" – 14" | 30" |
| 16" – 20" | 41" |
| 24" | 54" |
| 30" | 67" |
| 36" | 81" |

C. A 2" wide polyethylene tape shall be used for repairs and circumferential joints. The polyethylene tape shall have a minimum thickness of 12 mils.

D. Limits of Casing (from the Utility's main to the end of casing)

8' separation from edge of main to end of casing (4" and larger)

7.16 Service Saddles and Corporation Stops

A. Service Saddles

- Saddles to be used on DI and CI pipes for 1 1/2" and 2" taps for all pipe sizes. All 3/4"-1 1/4" taps on DI and CI pipes shall be direct tapped with no service saddle.
- All 3/4"-2" taps on 12" diameter or smaller C900 PVC pipe sizes shall use Ford Meter Box Company, Inc. bronze style saddles. All 3/4"-2" taps on 16" and larger C900 PVC pipe sizes shall use a stainless-steel saddle type JCM 438.
- For 4" and larger service taps see Section 7.06 Tapping Sleeves.
- All bolts shall be Type 304 stainless steel per ASTM A192. Threads shall be Teflon coated to reduce friction.
- Nuts shall be heavy hex, stainless steel per ASTM A193 Type 304.
- All gaskets shall be virgin WBR per ASTM MBC 610
- All Manufacturers shall be approved by the Utility.

WESTFIELD requires the use of Ford Meter Box Company, Inc. Bronze style saddles.

- B. Corporation Stop (Tap) - 3/4" through 2"
1. Tap shall be easy turning, O-ring sealed, balanced pressure plug valve having a round, full-open, unobstructed flow way.
 2. Body shall be one (1) piece with integral wrench slats.
 3. Operating head shall be large enough to provide adequate wrench gripping area.
 4. O-rings on top and bottom shall be provided to seal the valve.
 5. Threads shall be AWWA taper on inlet.
 6. Outlet shall be a compression connection, except 1 1/2" and 2" where FIP shall be provided.
 7. Shall be plug style valves.
 8. Shall be quarter-turn operation.
 9. All manufacturers shall be approved by the Utility

7.17 Tracing Wire, Splicing Connectors and Test Stations

- A. Tracing wire for open cut installation shall meet the following specifications:
1. Gauge, #10
 2. Direct Burial, 21% Conductivity Clad Steel Conductor, Soft Drawn High Strength Tracer Wire
 3. 600# Average Tensile Break Load
 4. Surface Legend Print on Insulating Jacket: printed at a minimum of every 2 linear feet
 5. 30 Mm, Blue, High Molecular Weight-High Density Polyethylene Jacket per ASTM D1248
 6. 30 V Rating
- B. Tracing wire for horizontal directional drilling or boring installation for 3"-16" diameter pipe shall meet the following specifications:
1. Copperhead Industries SoloShot™ Extra-High Strength Tracer Wire 1045 or approved equal.
 2. Gauge, #10
 3. Direct Burial, 21% Conductivity Clad Steel Conductor, Soft Drawn High Strength Tracer Wire
 4. Average Tensile Break Load: 2,032#
 5. Surface Legend Print on Insulating Jacket: printed at a minimum of every 2 linear feet
 6. 45 mil, Blue, High Molecular Weight Polyethylene Jacket rated for direct bury use at 600 volts per ASTM D1248
- C. Tracing wire for horizontal directional drilling or boring installation for 20" diameter pipe and larger shall meet the following specifications:
1. Copperhead Industries SoloShot™ X-treme PBX-50 or approved equal.
 2. Direct Burial, 21% Conductivity through 7 x7 stranded CCS (3/16" outside diameter) hard drawn, high carbon conductor
 3. Average Tensile Break Load: 4,700#
 4. Surface Legend Print on Insulating Jacket: printed at a minimum of every 2 linear feet
 5. 50 mil, Blue, High Molecular Weight Polyethylene Jacket rated for direct bury use at 600 volts per ASTM D1248

- D. Splicing connectors shall meet the following specifications:
1. SnakeBite brand wire connectors or approved equal
 2. Max. Voltage: 50V
 3. Connector Size: 1.138" x 1.285"
 4. Wire Range: #14-10 (380 and 1200 pound)
 5. Silicone Sealant Temperature Rating: -45 degrees Fahrenheit to 400 degrees Fahrenheit
 6. Part # 3WB-01 (Blue) or approved equal
- E. Test station shall meet the following specifications:
1. Material: Polypropylene
 2. Thread Size: 3/4" NPT
 3. Hardware: Stainless steel
 4. Number of Terminals:1
 5. Conduit Size: 24" Flexible PVC
 6. Color: Blue
 7. Accessories: Hydrant flange – 5/8" size
 8. Manufacturer: Copperhead Cobra T3 or approved equal

7.18 Identification Ribbon

- A. The marking tape shall be, non-detectable, blue in color and state, in permanent black letters, "Caution Buried Water Line Below". The tape shall be a minimum of 3" wide and be placed 24" below finished grade.

7.19 Casing Pipe

Details and requirements of these fabricated assemblies are shown on Standard Practice Drawing "I"-Typical Boring Casing Pipe.

- A. General

The inside diameter (ID) of the casing pipe shall be at least 12" greater than the outside diameter (OD) of the carrier pipe joints or couplings.

- B. Steel Casing Pipe

Steel casing pipe shall be bare-wall, spiral-welded steel pipe meeting ANSI/AWWA C206 with a minimum yield strength of 35,000 psi. Minimum wall thickness shall be as listed in the following table:

| Casing Outside Diameter | State Highway Crossings Casing Wall Thickness | Railroad Crossing Casing Wall Thickness |
|-------------------------|---|---|
| 24" | 0.312" | 0.406" |
| 30" | 0.375" | 0.469" |
| 36" | 0.500" | 0.532" |
| 42" | 0.500" | 0.563" |
| 48" | 0.625" | 0.625" |
| 54" | 0.625" | 0.688" |
| 60" | 0.625" | 0.750" |

Casing pipe for other applications shall comply with all local governmental standards and regulations. A minimum wall thickness of 3/8" shall be required.

Jack pipe shall be constructed as to prevent leakage of a substance from the pipe

throughout the entire length.

Pipe casing shall be beveled by square end.

C. Polyethylene Casing Pipe

HDPE casing pipe shall be SDR-13.5, PE3408 per AWWA C906, where approved by the Utility. Per INDOT standards, HDPE pipe shall only be utilized as casing pipe up to 24" unless otherwise approved by the Utility.

7.20 Vaults

A. For valves requiring remote operation, please contact the Plant Engineering group to discuss requirements.

B. Manufacturer(s) (Model) or CEG Approved Equal

1. Oldcastle Precast, Inc.
2. McCreary Concrete Products Inc.
3. Precast Solutions, Inc

7.21 Yard Hydrant

A. The yard hydrant shall include back flow preventer, automatic draining capabilities, freeze-proof design and able to maintain working components without any excavation.

B. The yard hydrant shall be equipped with a below grade water reservoir and venture designed value to discharge stored and flowing water. The yard hydrant shall also include a diverter spout with sleeve that can discharge water upstream of the backflow preventer. Pulling the sleeve will direct water through the backflow preventer with an integrated hose connection.

C. The water reservoir depth shall be based on the depth of bury. For mains 12" diameter and smaller, the minimum bury depth shall be of 5 feet. For mains 16" and larger, the minimum bury depth shall be 6 feet.

D. The backflow preventer shall be NIDEL® Model 37HF, ASSE 1052 with two check valves and 1" N.P.T. female inlet.

E. The yard hydrant shall have minimum and maximum pressure ratings of 20 psi and 100 psi, respectively. The unit shall have a maximum temperature rating of 120°F.

F. Manufacturer(s) (Model) or CEG Approved Equal

Woodford Mfg. Sanitary Yard Hydrant Model S3

END OF SECTION

SECTION 8.0 MATERIAL REQUIREMENTS FOR SERVICE LINES

8.01 General

The Contractor/Plumber shall furnish all materials necessary for the complete installation and associated construction of the service lines and all related appurtenances, except for corporation stops, tapping sleeves, tapping valves and the meter connection when connecting to Utility owned mains. The Contractor/Plumber shall furnish corporation stops, tapping sleeves, and tapping valves when connecting to a private main. The Utility will supply the meter connection for all service lines. All materials shall comply with the Standards.

The Utility will review and consider additions/deletions and changes to these material requirements on an as needed basis. All service line material for PVC water mains must be of like material. All materials shall be tested and verified that they meet all applicable AWWA/ANSI/ASTM/NSF standards, as well as all applicable Local, State and Federal laws.

8.02 Polyvinyl Chloride (PVC) Pipe (4" through 8" Diameter)

All PVC pipe shall be of a blue tint and conform to the latest edition of ANSI/AWWA C900. The pipe shall have the same outside diameter as ductile iron pipe. Materials from which the pipe is manufactured shall have been tested and approved for conveying potable water by the NSF and the U/L. All PVC pipe shall be marked with the U/L logo. Where fittings are required, DI fittings shall be used as specified in Section 8.03 "Ductile Iron Pipe and Fittings". All service lines above 8" diameter shall be DI or HDPE.

A. Wall Thickness, Small Pipe

Pipe wall thickness for 4", 6" and 8" diameter pipe shall be as required to provide a minimum wall thickness of DR 18 for Pressure Class 150, as defined by ANSI/AWWA C900.

B. Joints

Joints for PVC pipe shall be slip-on type with integral bell and spigot. Gasket lubricant shall be as specified by the pipe manufacturer.

8.03 Ductile Iron Pipe and Fittings

A. Ductile Iron (DI) Pipe

1. Unless indicated otherwise on the construction plans all 6" through 36" diameter pipe shall be Class 350; complete with all accessories and conforming to ANSI/AWWA C151/A21.51 with polyethylene encasement (refer to Section 7.15, "Polyethylene Encasement"). The joint shall be of the push joint (PJ) type conforming to ANSI/AWWA C111/A21.11. Gasket lubricant shall conform to ANSI/AWWA C111/A21.11. The pipe shall be cement mortar lined in accordance with ANSI/AWWA C104/A21.4 and shall be coated outside with a bituminous coating.

2. For restrained pipe, the locking segment slots shall be integral with the pipe bell. The working pressure of the restrained joint shall match the pipe. The number of locking segments and rubber retainers shall be as follows:

| Pipe Diameter | Number of Locking Segments | Number of Rubber Retainers |
|---------------|----------------------------|----------------------------|
| 4"-10" | 2 | 1 |
| 12"-20" | 4 | 2 |
| 24"-36" | 8 | 4 |

B. Ductile Iron Fittings

Ductile iron fittings shall be complete with all accessories and shall conform to ANSI/AWWA C110/A21.10, 350 pounds per square inch (psi) pressure rating requirements.

All fittings shall be cement mortar lined conforming to ANSI/AWWA C104/A21.4 and shall be coated outside with a bituminous coating or fusion-bonded epoxy.

Fittings shall have distinctly cast into the pipe exterior the pressure rating and letters "DI" or "DUCTILE". All DI fittings acceptable to the Utility shall be rated at a minimum of 70-50-05 (ksi tensile strength-ksi yield strength-percent elongation), in accordance with ANSI/AWWA C110 standards regarding strength of materials.

Fitting joints shall be of the standard mechanical joint (MJ) type conforming to ANSI/AWWA C111/A21.11 or push joint (PJ) type conforming to ANSI/AWWA C111/A21.11.

All T-head bolts shall be in accordance with AWWA C111/A21.11 and anti-corrosion type (blue bolt) by manufacturers such as Xylan or FluoroKote #1.

C. Compact Ductile Iron Fittings

Lightweight DI MJ or PJ type fittings shall conform to ANSI/AWWA C153/A21.53 and may be used at the Contractor's option. Fitting wall thickness shall meet or exceed ductile iron Class 53 and shall have a working pressure rating of 350 psi.

All fittings shall be cement mortar lined conforming to ANSI/AWWA C104/A21.4 and shall be coated outside with a bituminous or fusion bounded epoxy coating.

All T-head bolts shall be in accordance with AWWA C111/A21.11 and anti-corrosion type (blue bolt) by manufacturers such as Xylan or FluoroKote #1.

D. Mechanical Joint Fitting Accessories

MJ fitting accessories shall consist of gaskets, glands and T-head bolts with nuts. MJ fitting accessories shall conform to ANSI/AWWA C111 A21.11. T-head bolts shall be anti-corrosion type (blue bolt) by manufacturers such as Xylan or FluoroKote #1.

E. Viton Gasket Material for Ductile Iron Pipe

In construction areas where contaminated soils exist or existing steam utility lines may be installed, ductile iron pipe shall be required for installation with Viton gaskets in the pipe as approved by the Utility. Gasket lubricant shall be as specified by the pipe manufacturer.

8.04 Polyethylene (HDPE) Pipe and Fittings (3/4" through 2" Diameter)

A. Polyethylene Pipe

Polyethylene pipe shall conform to the latest edition of ANSI/AWWA C901 and ANSI/AWWA C906. Material used in the manufacture of HDPE pipe shall conform to the PE Standard Code PE 3408. All HDPE pipe 3/4" through 2" shall have the same outside diameter as copper tubing.

All HDPE pipe shall either be a blue shell with the AWWA specification stamp embedment or black shell with permanent blue-line print.

B. Wall Thickness

3/4" and 1-1/4" minimum pipe wall thickness shall be SDR 9.

1 1/2" through 2" minimum pipe wall thickness shall be SDR 11.

C. Joint Adapters for use on Polyethylene Pipe

Shall consist of one (1) piece construction from solid billet polyethylene

All polyethylene mechanical joint adapters shall be compression stop fittings to conform to AWWA C800.

Shall include a solid stainless-steel stiffener for all sizes

8.05 Polyethylene (HDPE) Pipe and Fittings (3" through 12" Diameter)

A. Polyethylene Pipe

Polyethylene pipe shall conform to the latest edition of ANSI/AWWA C901 and ANSI/AWWA C906. Material used in the manufacture of HDPE pipe shall conform to the PE Standard Code PE 3408. All HDPE pipes shall have the same outside diameter as DI pipe with the exception of 3" pipe, where iron pipe size shall be used.

All distribution network HDPE pipe shall have a blue shell or a minimum of six (6) longitudinal blue stripes, the AWWA specification stamp embedment or permanent blue-line print.

B. Wall Thickness

Distribution network piping minimum pipe wall thickness shall be Standard Dimension Ratio (SDR) 11 for pipe 3" through 36" in diameter.

C. Polyethylene Fittings

HDPE fittings shall utilize the same DR as the pipe being installed.

D. Polyethylene Mechanical Joint Adapters for use on Polyethylene Pipe (ductile iron pipe size (DIPS) Dimension Ratio (DR) 13.5 & 11)

All polyethylene mechanical joint adapters:

1. Shall consist of one (1) piece construction from solid billet polyethylene.
2. Shall include a stainless-steel integrated stiffener for sizes 16" through 36" (do not have to include stainless steel stiffener on sizes 6" through 12").
3. Shall utilize the same DR as the pipe being installed and ductile iron pipe size (DIPS).
4. Shall be of ductile iron pipe outside diameter, unless specified differently.
5. Shall allow enough clearance for full swing of butterfly valve action of disc.
6. Shall include complete mechanical joint (MJ) accessory kit including:
 - a. C110 full body, MJ heavy gland or machined steel gland of equal thickness.
 - b. Sufficient number and length MJ T-head bolts and nuts. T-Head bolts shall be in accordance with AWWA C111/A21.11 and anti-corrosion type (blue bolt) by manufacturers such as Xylan or FluoroKote #1.
 - c. Standard MJ gasket.

8.06 Copper Tubing and Fittings

A. Copper Tubing

All services installed within a one (1) square mile surrounding the City of Indianapolis, Indiana, near steam lines or petroleum transport lines shall be copper. Particular attention shall be given to the Mile Square section of the City, the downtown area bounded by North, East, South and West Streets. The boundaries, as described above, shall be the only area copper tubing is permitted unless approved by the Utility. All other areas within the CW territory shall be polyethylene pipe/tubing. Copper tubing shall conform to the latest addition of ANSI/AWWA C800. Material used in the manufacture of copper tubing shall conform to the ASTM B 88 for Type K copper tubing. Copper tubing Type K shall be permanently marked (incised) in accordance with its governing specifications to show tube type, the name or trademark of the manufacturer, and the country of origin.

WESTFIELD – For internal meter sets, copper tubing may extend from floor penetration to 5 feet outside the building. All other uses of copper tubing shall be prohibited in Westfield unless otherwise approved by the Utility.

B. Copper Fittings

All copper fittings shall be compression stop fittings to conform to AWWA C800.

8.07 Galvanized Pipe and Nipples

Galvanized pipe and nipples shall not be used.

8.08 Brass Nipples and Fittings

All brass nipples and fittings shall be manufactured in accordance with ANSI/AWWA C800. All brass nipples and fittings shall be certified by an ANSI accredited test lab per ANSI/NSF Standard 61, Drinking Water Components-Health Effects and shall comply with the Safe Drinking Water Act, and the United States Environmental Protection Agency.

8.09 Gaskets

Viton Gasket Material for Ductile Iron Pipe - in construction areas where contaminated soils exist or existing utility lines may be installed, ductile iron pipe shall be required for installation with Viton gaskets in the pipe as approved by the Utility. Gasket lubricant shall be as specified by the pipe manufacturer.

8.10 Dielectric Bushings

Dielectric couplings shall: be used when joining dissimilar metals to prevent galvanic action and corrosion; be suitable for the required working pressure; comply with the Safe Drinking Water Act, and the U.S. Environmental Protection Agency. Specifically, dielectric couplings shall be used when joining any dissimilar metallic service lines during a total service line replacement or partial service line replacement.

8.11 Valves

Gate Valves

- A. All 1 ½" and 2" gate valves shall be 200 psi, rising stem gate valves and shall conform to the requirements of ANSI/AWWA C509 or ANSI/AWWA C515. These valves are approved for buried and non-buried applications.

All 4" and larger gate valves shall be 200 psi, ductile iron body, and resilient-seated, tight closure gate valves with non-rising stems in accordance with all applicable requirements of ANSI/AWWA C509 or ANSI/AWWA C515. Non-rising stem gate valves are approved for direct bury applications only. Rising stem gate valves are not approved for buried applications.

Valve Ends

All 1 ½" and 2" gate valve ends shall be of the female iron pipe threads. All 4" and larger gate valve ends shall be of mechanical joint or flanged face type and shall conform to ANSI/AWWA C111/A21.11.

- B. See Table 8.11.1 below for opening orientation by Territory Area
- C. Acceptable Manufacturers

All manufacturers shall be approved by the Utility.

Tapping Valves

- A. See Table 8.11.1 below for opening orientation by Territory Area
- B. Acceptable Manufacturers

All manufacturers shall be approved by the Utility.

Table 8.11.1 Valve Opening Orientation

| | CW Territory | | | | |
|-------------------|-----------------------------------|------------------------|------------------------|------------------------------|------------------------------|
| | Marion County & Surrounding Areas | Noblesville | East Morgan County | Southern Madison | Westfield |
| Valve Orientation | Open Right (Clockwise) | Open Right (Clockwise) | Open Right (Clockwise) | Open Left (Counterclockwise) | Open Left (Counterclockwise) |

8.12 Inlet and Outlet Valves

Inlet and outlet connections shall be 3/4” for 5/8” meter settings, 1” in size for 3/4” meter settings, 1 1/4” for 1” meter settings. The inlet sizes shall be a minimum of one (1) pipe size larger than the meter size for all other larger services.

A. Inlet Connections

1. Angle valves shall only be used on the inlet side of the water meter on service lines 3/4” to 1 1/4”.
2. The angle valve shall be designed and manufactured as specified in ANSI/AWWA C800 regarding thread types and diameters. The valve shall be certified to be capable of withstanding a minimum working pressure of 150 psi with a pad-locked wing, a 90-degree rotating valve that opens counterclockwise (left).
3. All manufacturers shall be approved by the Utility.

B. Outlet Connections

1. Angle valve on the outlet side of the water meter shall be equipped with a shut-off handle.
2. The angle valve shall be designed and manufactured in accordance with the AWWA Standard C800 regarding thread types and diameters. The valve shall be certified to be capable of withstanding a minimum working pressure of 150 psi with a 90-degree rotating valve that opens counterclockwise (left).

WESTFIELD – Refer to Westfield Standard Drawings for valve types.

8.13 Valve Box, Lid and Riser (>4” valves installed within public right-of-way or easements)

A. Cast Iron Valve Box and Lid

Special Utility CI valve box and lid shall be installed for each valve and blow-off assembly with a plastic riser as specified in CW Standard Practice Drawing “G”-Standard 8” Valve Box and Cover.

WESTFIELD- Valve boxes see section 7.08

B. Valve Box Riser

A solid ribbed 8" diameter PVC riser shall be required and shall be centered over the valve. If the valve is 6' deep or greater, a valve nut extension shall be installed to bring the operating nut to a depth 4' below finished grade.

WESTFIELD- Valve boxes see section 7.08

8.14 Valve Box, Lid and Riser (1 1/2" and 2" Curb Stops)

A. Cast Iron Valve Box and Lid

A Special Utility 5-1/4" CI valve box, lid, and plastic riser shall be installed for each 1 1/2" and 2" curb stop

B. Valve Box Riser

A solid 4" diameter PVC riser will be required and shall be centered over the valve.

8.15 Blow-off Assembly (3" through 12" Service Lines)

- A. The blow-off assembly (refer to CW Standard Practice Drawing "J"-2" and CW Standard Practice Drawing "K"-2") shall be of an automatic freeze-proof design with a drain/weep hole drilled within a 2" ball valve. Valve shall be 600-lb. WOG bronze body with chrome plated brass ball with Teflon seals and stainless-steel bolts.

WESTFIELD – Temporary hydrants shall be utilized for blow-offs.

8.16 Joint Restraint Devices

- A. Joint restraint devices shall be used at all bends and fittings as well as thrust (refer to CW Standard Practice Drawing "O"-Installation of Restraints). Joint ends shall be PJ type or MJ.
- B. Ductile Iron Pipe: Restraint devices shall be used at bell and spigot joints and shall consist of one (1) wedge actuated restraint and (1) split ductile iron ring for new pipe and per one (1) split wedge actuated restraint and (1) split ductile iron ring for existing pipe.
1. Manufacturer(s) (Model) or CEG Approved Equal:
 - EBAA IRON (1700 Series – for new pipe; 1100HD – for existing pipe)
 - Ford Meter Box Company, Inc. (Series 1455 – for new pipe; Series 1490 – for existing pipe)
- C. PVC Pipe: Restraint devices shall be used at bell and spigot joints and shall consist of two (2) split, serrated restrainers.
1. Manufacturer(s) (Model) or CEG Approved Equal:
 - EBAA IRON (1900 Series)
 - Star (1100 Series)
 - Ford Meter Box Company, Inc. (1390 Series)

8.17 Cross-Laminated Polyethylene Encasement

- A. High density cross-laminated polyethylene encasement materials shall be used for ductile iron pipe and fittings. The high-density cross-laminated polyethylene

tube material shall conform to ANSI/AWWA C105 with a minimum thickness of 4 mils.

B. Tube Diameter

The minimum tube size for each pipe diameter shall be as follows:

| Nominal Diameter | Polyethylene Flat Tube Width |
|------------------|------------------------------|
| 3" – 4" | 20" |
| 8" – 12" | 30" |

- C. A 2" wide polyethylene tape shall be used for repairs and circumferential joints. The polyethylene tape shall have a minimum thickness of 12 mils.

8.18 Service Saddles and Corporation Stop

A. Service Saddles

1. Saddles to be used on DI and CI pipes for 1 1/2" and 2" taps for all pipe sizes. All 3/4"-1 1/4" taps on DI and CI pipes shall be direct tapped with no service saddle.
2. All 3/4"-2" taps on 12" diameter or smaller C900 PVC pipe sizes shall use Ford Meter Box Company, Inc. bronze style saddles. All 3/4"-2" taps on 16" and larger C900 PVC pipe sizes shall use a stainless-steel saddle type JCM 438.
3. All bolts shall be Type 304 stainless steel per ASTM A193. Threads shall be Teflon coated to reduce friction.
4. Nuts shall be heavy hex, stainless steel per ASTM A194 Type 304.
5. All gaskets shall be virgin WBR per ASTM MBC 610
6. All Manufacturers shall be approved by the Utility.

WESTFIELD- Requires the use of Ford Meter Box Company, Inc. Bronze style saddles.

B. Corporation Stop (Tap) - 3/4" through 2"

1. Tap shall be easy turning, O-ring sealed, balanced pressure plug valve having a round, full-open, unobstructed flow way and working pressure of 300 psi.
2. Body shall have AWWA taper threads on inlet.
3. Operating head shall be large enough to provide adequate wrench gripping area.
4. Molded EDPM rubber seat with reinforcing ring supports the ball.
5. Solid one-piece tee-head and stem with dual EDPM O-rings in the stem.

6. Shall be quarter-turn operation.
7. All manufacturers shall be approved by the Utility.

8.19 Tracing Wire/Splicing Connectors

- A. Tracing wire for open cut installations shall meet the following specifications:
 - Gauge, #10
 - Direct Burial, 21% Conductivity Clad Steel Conductor, Soft Drawn High Strength Tracer Wire
 - 600# Average Tensile Break Load
 - Surface Legend Print on Insulating Jacket Printed At A Minimum Of Every 2 Linear Feet
 - 30 Mm, Blue, High Molecular Weight-High Density Polyethylene Jacket Per ASTM D1248
 - 30 V Rating
- B. Tracing wire for horizontal directional drilling or boring installation for 3"-16" diameter pipe and shall meet the following specifications:
 - Copperhead Industries SoloShot™ Extra-High Strength Tracer Wire 1045 or approved equal.
 - Gauge, #10
 - Direct Burial, 21% Conductivity Clad Steel Conductor, Soft Drawn High Strength Tracer Wire
 - Average Tensile Break Load: 2,032#
 - Surface Legend Print on Insulating Jacket: printed at a minimum of every 2 linear feet
 - 45 mil, Blue, High Molecular Weight Polyethylene Jacket rated for direct bury use at 600 volts per ASTM D1248
- C. Splicing Connectors shall meet the following specifications:
 - Manufacturer: SnakeBite brand wire connectors or approved equal
 - Max. Voltage: 50V
 - Connector Size: 1.138" x 1.285"
 - Wire Range: #14-10 (380 and 1200 pound)
 - Silicone Sealant Temperature Rating: -45 degrees Fahrenheit to 400 degrees Fahrenheit
 - Part #: 3WB-01 (Blue) or approved equal

8.20 Identification Ribbon

The marking tape shall be blue in color and state "Caution Buried Water Line Below". The tape shall be a minimum of 3" wide and be placed 24" below finished grade.

8.21 Casing Pipe

Details and requirements of these fabricated assemblies are shown on CW Standard Practice Drawings "I"-Typical Boring Casing Pipe.

- A. General

The inside diameter (ID) of the casing pipe shall be at least 12" greater than

the outside diameter (OD) of the carrier pipe joints or couplings.

B. Steel Casing Pipe

Steel casing pipe shall be bare-wall, spiral-welded steel pipe meeting ANSI/AWWA C206 with a minimum yield strength of 35,000 psi. Minimum wall thickness shall be as listed in the following table:

| Casing Outside Diameter | State Highway Crossings Casing Wall Thickness | Railroad Crossing Casing Wall Thickness |
|-------------------------|---|---|
| 24" | 0.312" | 0.406" |

Jack pipe shall be constructed as to prevent leakage of a substance from the pipe throughout the entire length.

Pipe casing shall be beveled by square end.

C. Polyethylene Casing Pipe

Casing pipe 2" through 4" in diameter shall be PE3408 Polyethylene with a minimum SDR 21 wall thickness. Casing pipe 8" through 24" in diameter shall be either PE3408 Polyethylene with a minimum SDR 21, or spiral welded steel pipe meeting AWWA C206 with a minimum wall thickness 3/8", or PVC pipe with a minimum SDR 35 wall thickness.

Casing pipe for other applications shall comply with all local governmental standards and regulations. A minimum wall thickness of 3/8" is required.

HDPE casing pipe shall be SDR-13.5, PE3408 per AWWA C906, where approved by the Utility.

D. Limits of Casing (from the Utility's main to the end of casing):

- 4' separation from edge of main to end of casing (3/4" – 1 1/4")
- 6' separation from edge of main to end of casing (1 1/2" – 2")
- 8' separation from edge of main to end of casing (4" and larger)

8.22 Vaults

A. General

Vaults shall be required on all metered lines 1 1/2" in diameter or larger for outdoor installations.

Vaults may be required for non-metered fire services 2" in diameter or larger to house double-check assemblies as determined by the Utility. See Standard Practices Drawings T.WF6 and Y.1-Y.8 for additional information about Citizens Westfield and Citizens Water vaults.

B. Material

Vaults shall be prefabricated or cast-in-place concrete. Concrete shall be a minimum of 5,000 psi. Concrete wall thicknesses shall be specified by the Professional Engineer and submitted to the utility for review. Soils and site-specific conditions shall be considered when designing the wall thicknesses

for the vaults.

C. Vault Lids

For 1 ½” and 2” meters, manway openings for vaults shall be a Ford Meter Box Company, Inc. #10 ring and lid or equal.

Manway openings for meters larger than 2” shall be a Bilco Access Door and Frame type J-2, U.S.F. Fabrication, Inc. Model TPS or approved equal. Opening size shall be in accordance with the Standard Practice Drawings.

D. Steps

All vaults shall be equipped with non-slip type steps and shall be Neenah R-1980C pre-cast steps or equal. Steps shall be set in concrete or masonry spaced horizontally 1’ on center.

E. Hoist Ring

All vaults housing meters 4” in diameter or larger shall be equipped with a hoist ring.

8.23 Meter Pits

A. General

All meter pits shall adhere to CW Standard Practice Drawing “T”-Standard Service Line Installation and Setting For 5/8”, 3/4”, and 1” Meters and CW Standard Practice Drawing Z - Polyethylene Service Line Meter Support

All 1-1/2 water meters shall adhere to CW Standard Practice Drawing T.4 Dual Meter Connection with Dual RPZ or Citizens Westfield Standard Practice Drawing T.WF7 Dual Meter Connection with Dual RPZ.

WESTFIELD – Refer to Standard Drawings for Westfield Meter Pits.

B. Meter Pit Lid and Ring

For 5/8”, 3/4” and 1” meters, a composite pit lid shall be installed with a metal expansion ring and pit liner.

C. Meter Pit Riser

For 5/8” and 3/4” meters, the meter pit shall consist of a 20” in diameter riser or equal. For 1” meters, the meter pit shall consist of a 24” in diameter riser or equal. All risers shall be 48” in depth.

8.24 Insulated Enclosures

Insulated enclosures shall be installed on a minimum 4” thick concrete pad and shall be wired to comply with the National Electrical Code and all Local and State requirements.

8.25 Backflow Protection Devices

- A. Backflow prevention and cross connection control shall be provided as required by 327 IAC 8-10.
- B. Acceptable Devices

All devices used for backflow prevention where potable water is or may be provided downstream of the device shall be lead free and meet NSF-61 standards for application in potable water systems. All fixtures located after a backflow protection device that do not meet NSF 61 standards for "lead free" must have a permanent label in a minimum font size of three inches (3") in height stating "For Non-Potable Use Only. Do Not Drink." affixed to the front of it.

Any dedicated fire line over 150' in length with no domestic service will require a DCDA backflow preventer (or RPDA in hot box located above grade if chemical additive e.g. glycol is used) installed at the property line in an approved vault. In addition, any water service combination line of substantial length that may be considered high risk by the Utility may require a DCA in an approved vault or RPZ (high hazard) in an approved hot box installed at the property line.

8.26 Installation of Flow Reducers

- A. In the application where flow reducers are installed, they must be approved by the utility and must be a minimum of 5 times the pipe diameter after the meter, and 10 times the pipe diameter before the meter.

END OF SECTION

SECTION 9.0 INSTALLATION REQUIREMENTS FOR WATER MAINS AND SERVICE LINES

9.01 General

All water main and service line installation and restoration shall conform to the Standards and be performed in accordance with all State, Federal, Local codes and regulations. All methods shall adhere to the best practices of the water utility industry and the American Water Works Association.

All water main pipe materials and appurtenances shall comply with Section 7.0, "Material Requirements for Water Main Installation of these Standards.

All service line pipe materials and appurtenances shall comply with Section 8.0 "Material Requirements for Service Lines of these Standards.

The Contractor/Developer shall be responsible for obtaining all permits prior to the performance of the required work.

Additional requirements are as follows:

- A. Contractor/Developer shall notify the Utility immediately when an existing lead service line is encountered during construction. Connection to an existing lead service line within the right-of-way is not permitted.
- B. Prior to installing a water main(s), a pre-construction meeting shall be held between the Contractor/Developer and the Utility's representative for each project. The Contractor/Developer shall be responsible for contacting the Utility's representative to schedule this meeting.

All materials necessary to complete the water main(s) installation shall be on-site at the time of the pre-construction meeting for inspection and approval by the Utility prior to installation.

All required permits shall be available for review at the time of the pre-construction meeting.

- C. Construction shall commence within one (1) year after release for construction by the Utility.

If a construction delay of ten (10) days or more should occur on a project, a written notification shall be submitted to the Utility, a minimum of three (3) working days before construction can resume.

- D. If an existing customer may experience a disruption of service, the Contractor/Developer shall notify the Utility a minimum of three (3) working days prior to the outage. The Contractor/Developer may not disrupt existing service without the approval of the Utility.

If the Developer/Contractor cancels the work, the Contractor/Developer's shall be responsible for all associated costs involved in the re-notification of customers.

Any existing appurtenances (e.g., valves, blow-off assemblies, etc.) shall be operated by the Utility only.

- E. The main extension and/or service line construction site shall be accurately surveyed and staked with a PVC pipe or 2"x2" wooden grade stake in accordance with the approved plans.
- F. The Utility will examine all pipeline materials prior to and during the construction phase, as well as confirm that work performed complies with the Standards and the main extension contract. The Contractor/Developer shall furnish all reasonable assistance as required during the inspection and shall abide by directives and instructions from the Utility.

Service lines 1¼" in diameter and smaller are inspected at the time of the service connection ("tap").

- G. Any damage made to the Utility's system by the Contractor/Developer or their affiliates shall be immediately repaired to the satisfaction and direction of the Utility. All such repairs shall be at the Contractor/Developer's expense.
- H. Should the Contractor/Developer propose to deviate from the approved plans, a revised set of plans shall be submitted to the Utility for approval. A stop work order will be immediately issued to the Contractor/Developer until such alternative is approved.
- I. No work shall be performed under conditions that could, in the opinion of the Utility, adversely affect the quality of the finished project.
- J. The Contractor/Developer shall conduct the work, so as not to interfere with the present operation of the existing Utility's plant or facilities. If any work interference is encountered between the Utility and the Contractor/Developer, the Utility shall receive priority in scheduling.
- K. The Contractor/Developer shall cover buried steel lugs, rods, brackets and bolts with one coat of coal tar epoxy such as Koppers 50 or equal prior to installing polyethylene encasing and backfill.
- L. Water mains and service lines shall be disinfected and hydrostatically tested in accordance with Appendix C-Construction Testing Methods.
- M. The Contractor/Developer shall be responsible to adjust all meter pits, valve boxes, curb boxes and fire hydrants to finished grade, as specified in CW Standard Practice Drawing "B"-Standard Hydrant, , CW Standard Practice Drawing "S"-Standard Installation for Multiple Meter Settings, CW Standard Practice Drawing "T"-Standard Service Line Installation and Setting for 5/8", 3/4" and 1" Meter in Single Pit, and CW Standard Practice Drawing "Z"-Polyethylene Service Line Meter Support (Single Meter Set)

WESTFIELD – Refer to the Citizens Westfield Standard Practice Drawings (T.WF#). These details shall be utilized in Westfield service territory; otherwise, the Citizens Water Standard Practice Drawings are to be utilized.

- N. The Utility shall receive a submittal of all final documents prior to authorizing service from the existing water mains to the newly installed water mains.

- O. The Contractor/Developer shall conduct an inspection annually from the in-service date and shall be documented as specified in -Water Main and Service Line Close-Out Checklist.
- P. The Utility will perform an inspection prior to the expiration of the Maintenance Bond and notify the Contractor/Developer of any necessary corrections. If corrections are not made prior to the release of the Maintenance Bond, the Utility will make necessary repairs and shall be reimbursed for all costs by the Contractor/Developer.
- P. If additional testing (e.g., sterilization, flushing, sampling, leak survey, continuity testing, hydrostatic testing, etc.) is required, the Developer shall be required to pay all related costs on a time and material basis. The project will not be released for service connection until all described testing has been properly demonstrated, documented and approved by the Utility.
- Q. The Contractor/Developer shall be responsible for all costs resulting from any corresponding damages related to the Section 9.0-Installation Requirements for Water Main.
- R. All “trenchless” installations (e.g. directional bores, casing bores, etc.) shall be completed prior to receiving the service connection (“tap”).

9.02 Material Handling and Storage

All materials furnished by the Contractor/Developer, including pipe, fittings, valves, hydrants and other accessories, shall at all times be handled with care to avoid damage. During loading and unloading, a hoist shall be used to lift all materials in such a manner as to avoid shock. Under no circumstances shall materials be dropped, rolled or dumped.

During loading, unloading, moving, and/or setting of pipes, valves, fittings, hydrants, and appurtenances, hooks shall not be permitted to come into contact with joint surfaces. Chains or cables shall be used for these purposes for ductile iron material. Nylon or another fabric-type sling shall be used for PVC or HDPE material.

The Contractor/Developer shall ensure that all materials are protected from adverse and/or hazardous conditions while on the project site until installation is completed.

9.03 Public Utilities

The Contractor/Developer installing a water main(s) shall provide “Record Drawing” plans that illustrate all information available on existing and proposed improvements including, but not limited to: sewers, culverts, gas lines, ducts, conduits, cables, pipes, etc.

The Contractor/Developer shall notify all utilities in accordance with applicable State standards, ordinances or other Local provisions.

Temporary support, adequate protection and maintenance of all underground and surface utility structures, drains, sewers and other obstructions encountered during project progression shall be furnished by the Contractor/Developer at their own expense.

The Contractor/Developer shall immediately contact the appropriate utility should any damage be made to their facilities. Such damage shall be repaired in accordance with

the directive and to the satisfaction of the affected utility. All repairs shall be at the Contractor/Developer's expense.

9.04 Alignment and Grade

All storm and sanitary sewers shall be installed prior to the installation of the water mains. Water mains and service lines shall be installed such that the minimum horizontal and vertical separation distance from all sewers is in accordance with Indiana Administrative Code, Title 327 and as specified in CW Standard Practice Drawing "A"-Water and Main Separation Detail.

A rough grade shall be established within 6" of proposed final grade prior to water main installation.

Piping alignment and depth shall be installed, consistent with the approved plans and in accordance with the Standards and the Indiana Administrative Code, 327 IAC 8-3.2-17. No deviation shall be made from the horizontal and/or vertical alignment or grade prior to the approval of the Utility.

Changes in piping direction may only be accomplished by the use of manufactured bend fittings and the allowable deflection of pipe materials as recommended by the pipe manufacturer. Whenever it's necessary to deflect ductile iron pipe from a straight line to avoid obstructions, either in the vertical or horizontal plane, to plumb valve operating stems or for other reasons, the degree of deflection shall be approved by the Utility as recommended by the pipe manufacturers.

Mandatory pipe cover shall be 54" below finished grade or as required by 327 IAC 8-3.2-17. Depth of bury greater than 54" shall be approved by the Utility prior to installation and pipe with specific pressure class and material may be required.

The Contractor/Developer shall use survey instruments when necessary to avoid potential conflicts and/or maintain alignment and grade.

9.05 Trench Excavation, Preparation and Backfill

A. Description

The trench shall be dug to the alignment and depth required by these Standards and the approved plans, but only so far in advance of pipe laying and/or tapping as the work permits. Tap excavation need to be shored in accordance with the current OSHA Standards. Consideration shall be given to any proposed and foreseeable future grade changes. The trench shall be so braced and drained such that workers may perform their duties therein to avoid potential contamination of the water main during installation. Water from trench dewatering shall not be allowed to enter the pipe.

B. Width

The trench width may vary depending upon the depth of trench and the nature of the excavated material encountered. However, the trench shall be the necessary width to facilitate proper installation. Per the AWWA Principles and Practices of Water Supply Operation, "Trench width below the top of the pipe should generally be no more than 1 to 2 ft. greater than the outside diameter of the pipe." Excessive trench widths for smaller diameter pipe should be avoided if at all possible.

Maintaining a narrow trench width in all areas, if possible, shall be considered. Refer to table 1 and 2 provided below for recommended trench widths per AWWA Principles and Practices of Water Supply Operation.

Table 9.05.1 Trench Widths for Ductile Iron Pipe

| Nominal Pipe Size | Recommended Trench Widths |
|-------------------|---------------------------|
| <i>In.</i> | <i>In.</i> |
| 4 | 28 |
| 6 | 30 |
| 8 | 32 |
| 10 | 34 |
| 12 | 36 |
| 16 | 40 |
| 20 | 44 |
| 24 | 48 |
| 30 | 54 |
| 36 | 60 |
| 48 | 72 |
| 54 | 78 |

Table 9.05.2 Trench Widths for PVC Pipe

| Nominal Pipe Size | Recommended Trench Widths | |
|-------------------|---------------------------|----------------|
| | <i>Minimum In.</i> | <i>Maximum</i> |
| <i>In.</i> | | |
| 4 | 18 | 29 |
| 6 | 18 | 31 |
| 8 | 21 | 33 |
| 10 and Greater | 24 | 36 |

C. Support

The trench shall be excavated to provide a uniform and continuous bearing of support for the pipe barrel and joints.

D. Bedding and Backfill

Backfilling shall be initiated as soon as possible after the placement of pipe in the trench and performed in a manner so as not to damage the pipe or pipe coating. The Utility has the right to alter the backfill procedure, so as to give maximum protection to the pipe and coating. All tap excavations are required to be backfilled with granular fill to the point 2' above the water main. For the utility backfill requirements, reference CW Standard Practice Drawing "A.1" – Water Main and Service Backfill Requirements.

No trash, e.g., sticks, welding rod, stumps or refuse material of any kind, shall be buried within the trench. After the pipe has been properly installed and the trench has been properly backfilled by the Contractor/Developer, excess excavated material shall be removed from the construction site and properly disposed in accordance with all Federal, State, and Local regulations by the Contractor/Developer.

All backfill in public right-of-way shall conform to the rules and regulations of the prevailing governmental authority. All backfill shall conform to the pipe

manufacturers' specifications, and shall be clean, non-corrosive, compactable, and free of rock.

E. Sewer and Drainage Flow Maintenance

Adequate provisions shall be made for the continuous flow and operations of sewers, drains and watercourses encountered during construction. Structures that may have been disturbed shall be satisfactorily restored to avoid contamination of the water main at the expense of the Contractor/Developer.

9.06 Erosion Control

The Contractor/Developer shall be responsible to ensure that each applicable construction site shall be in compliance with all the applicable sections of 327 Indiana Administrative Code (IAC) 15-5 (Rule 5).

<https://www.in.gov/idem/stormwater/2370.htm>

9.07 Contaminated Soils

A. General

If suspected contaminated soils based on odor, discoloration, etc. are encountered during construction of the water main facilities, the Contractor/Developer shall immediately cease work and notify the Utility. The Contractor/Developer shall comply with all Local, State and Federal regulations including notification of authorities regarding the contaminated materials.

B. Water Main and Service Line Material Requirements

Only DI pipe, inert gasket material and fittings shall be used in areas in close proximity of contaminated soils. The pipe must be double-wrapped and secured appropriately at the joints with cross-laminated polyethylene wrap. See Section 7.15 for requirements.

C. Testing

The Contractor/Developer shall be responsible for all corresponding fees related to contaminated soil (e.g., sampling, testing, permits, disposal, etc.).

D. Disposal of Contaminated Soil

The Contractor/Developer shall dispose of contaminated soils in accordance with all Local, State and Federal regulations. The Contractor/Developer shall be listed solely as the waste generator.

The Contractor/Developer shall notify the Utility of all projects involving contaminated soils including all supporting documentation.

E. The Contractor/Developer shall document location including length and width of contaminated soil on the Record Drawings.

9.08 Service Taps

A. General

1. Tap placement shall be a minimum of 3' from any existing fitting or tap. Any deviation from 3' must be approved by the Utility.
2. No "back side" taps are allowed on any size water main, unless approved by the Utility.
3. All 1-1/2" and 2" taps require installation of a swing joint between the tap and curb stop. See CW Standard Practice Drawing 'N' – 1-1/2" & 2" Service Line Swing Joint. Any other tap shall be directly in line with the water service.
4. Taps are not permitted on pipes 24" diameter and larger.
5. Tap holes shall be shored according to OSHA standards and be sufficient to support tap valve and employees during installation.
6. The Contractor/Developer shall provide equipment to set material, perform tap and dewater tap hole if necessary.
7. All bores must be in before tap will be performed.

B. Tap Hole Standards

| Requirements | Tap Diameter | | |
|--|--------------|-------------|---------------|
| | 4"-12" | 1-1/2" – 2" | 3/4" – 1 1/4" |
| Trench width, minimum | 5' | 5' | 4' |
| Distance from tap side (front) main to front of hole | 7' | 4' | 4' |
| Distance from back of main to back of hole | 2' | 1' | 1' |
| Distance from bottom of main to bottom of hole | 1' | 1' | 1' |
| Length of exposed main in middle of trench | 3' | 2' | 18" |

Any deviation from these standards must be approved by the Utility prior to beginning taps. Disregard of these standards could result in rejection of future permit applications.

9.09 Pipe Installation

A. General

1. Materials Inspection

Before lowering any materials into the trench for assembly, the pipe, fitting, valve or fire hydrant shall be thoroughly inspected by the Contractor/Developer. Any defective, damaged, or unsound material shall not be installed and shall be immediately removed from the job site.

Contractor/Developer shall confirm proposed materials are suitable when depth of bury exceeds 9 feet and follow manufacturer's installation requirements.

2. Materials Cleanliness

Prior to installation, pipe shall be free of all foreign matter and the interior cleaned by swabbing before it is placed in the trench. No debris of any kind shall be left in the bell and/or spigot.

The pipe swabbing shall be performed as explained in Appendix C-Construction Testing Methods by using pipe swab brushes comprised of Tampico brush material.

3. Concrete Thrust Blocking

Blocking shall be installed as shown on the plan drawings and as specified in Section 9.15.

4. Pipe Closures

When necessary or at the end of the day, the open ends of the installed pipe shall be closed by with a watertight plug and at no time shall trench water be permitted to enter the pipe.

5. Pipe Cutting

When cutting pipe for inserting valves, fittings or closure pieces, it shall be performed in a neat and workmanlike manner without damage to the pipe.

PVC or DI pipe to be inserted into a push-on joint bell end shall have the cut end beveled in accordance with the manufacturer's instructions so as to prevent the edge of the pipe from cutting or tearing the gasket as the spigot end is inserted into the bell of the adjoining pipe or fitting.

PVC pipe inserted into a fitting, valve or other appurtenance with a MJ connection shall have the factory tapered or beveled end removed from the end of the pipe to make the pipe end square.

When cutting HDPE, the cut end of the pipe shall be squared as much as possible prior to facing. Field cutting of HDPE pipe 8" in diameter or smaller can be accomplished using a pipe saw without damaging the pipe ends due to melting. To cut HDPE pipe with a diameter larger than 8", a chain saw with a glycerin-based lubricant shall be used.

6. Charging, Flushing, Air Removal and Hydrostatic Testing

Any charging, flushing, air removal and hydrostatic testing shall be conducted as specified in Section 9.19, "Charging, Flushing, Air Removal and Hydrostatic Testing" and Appendix C-Construction Testing Methods.

B. Polyvinyl Chloride (PVC) Pipe

1. Installing Pipe

After placing a length of PVC pipe in the trench, the spigot for the joints shall be properly positioned and the gasket lubricated in accordance with manufacturer's requirements. The spigot end shall then be centered in

the bell, the pipe forced to the marks on the pipe and brought into true alignment.

No more than two (2) joints shall be exposed at any one time.

2. Deflection of Pipe Joints

The deflection of pipe joints shall not be allowed.

3. Mechanical Pipe Joints

After the preparation of the pipe ends for a mechanical joint connection, the retainer gland shall be installed such that the bolts may be tightened in accordance with the manufacturer's recommendations. The gasket shall be lubricated per the manufacturer's instructions and inserted in the bell by drawing the gland toward the bell. The bolts shall be drawn up uniformly on opposite sides of the mechanical joint fitting per the manufacturer's torque and specification procedures.

4. Pipe Joint Restraints

Pipe joint restraints shall be installed as specified in Section 9.16, "Pipe Joint Restraint Devices." See CW Standard Practice Drawing "O"-Installation of Restraints.

5. Tracing Wire and Identification Ribbon

The tracing wire and identification ribbon shall be installed as specified in Section 9.17, "Installation of Tracing Wire and Identification Ribbon"

C. Ductile Iron (DI) Pipe and Fittings

1. Installing Pipe

Following the placement of a length of DI pipe in the trench, the gasket material for the joint shall be properly positioned and lubricated in accordance with the manufacturer's recommendations. The spigot end shall then be centered in the bell, the pipe forced to the marks on the pipe and brought into true alignment.

2. Permissible Deflection of Pipe Joints

The degree of deflection shall not exceed the manufacturer's specifications.

3. Preparation of Pipe Ends

Before installing the pipes, all lumps, blisters, and excess coal tar coating and other foreign material shall be removed from the inside of the bell and outside of the spigot ends of each pipe. The pipe surfaces shall then be wiped until clean and dry.

4. Mechanical Joint Fittings

After the preparation of the pipe ends for a mechanical joint connection, the

retainer gland shall be installed such that the bolts may be tightened in accordance with the fitting and gland manufacturer's recommendations. The gasket shall be lubricated per the manufacturer's instructions and inserted in the bell by drawing the gland toward the bell. The bolts shall be drawn up uniformly on opposite sides of the mechanical joint fitting per the manufacturer's torque and specification procedures.

5. Pipe Joint Restraints

Joint restraints shall be installed in accordance with the manufacturer's guidelines as needed to provide a continuous secure pipe that is not affected by the resultant thrust forces of the distribution system, as specified in CW Standard Practice Drawing "O"-Installation of Restraints.

6. Restrained Joint Pipe

Restrained joint pipe shall be installed in accordance with the manufacturer's specifications.

7. Polyethylene Wrap

Cross laminated poly wrap shall be required. See Section 7.15 for requirements.

8. Tracing Wire and Identification Ribbon

The tracing wire and identification ribbon shall be installed as specified in Sections 9.18 and 9.19.

D. Polyethylene (HDPE) Pipe

1. Materials Inspection

Before lowering any materials into the trench for assembly, the HDPE pipe, fitting, valve assembly or hydrant assembly shall be thoroughly inspected by the Contractor/Developer so as to determine any defects, damage or unsoundness of the material. Any defective, damaged, or unsound pipe or appurtenance shall be rejected. At any point along the polyethylene pipeline where 10% of the wall thickness has been penetrated or removed by way of marring, gouging or abrasion, that damaged section of pipe shall be deemed unsound and shall be removed and replaced with a new, clean section of polyethylene pipe.

2. Water Stop/Thrust Restraints

To help minimize the effects of thermal contraction and expansion for HDPE pipe, water stops shall be installed as shown on CW Standard Practice Drawing "U" Minimum Requirements for Water Stop Installation and U.1 Flexible Restraints Saddles.

Water stops shall be required at every change in materials. Use Compression fitting with concrete collar for 1-1/2" and 2" pipes. Use a fused poly collar for 3" and larger pipe.

| Minimum Soil Bearing Surface Area Required for Water Stop Installation in Undisturbed Material (Assuming 3,000 psi Soil Bearing Capacity) | |
|--|--|
| Pipe Size | Minimum Bearing Surface (ft ²) |
| 3"-4" | 6 |
| 6" through 12" | 8 |
| 16" | 15 |
| 20" | 24 |
| 24" | 36 |

3. Allowable Deflection of HDPE Pipe

The maximum allowable deflection of HDPE pipe shall not exceed the manufacturer's recommendations. Where the maximum allowable deflection is insufficient to achieve the required change in direction, a molded or fabricated butt-fused bend or MJ fitting with MJ adapter shall be used. Deflection of HDPE pipe shall not be permitted at any in-line, butt-fused, fabricated or molded fitting.

4. Tracing Wire and Identification Ribbon

The tracing wire and identification ribbon shall be installed as specified in Section 9.17, "Installation of Tracing Wire and Identification Ribbon".

5. River Weights

Where HDPE pipe is installed at stream crossings by means of open cutting the streambed, river weights shall be used to prevent the HDPE pipe from floating during installation. The weights shall be composed of concrete.

6. Joining of HDPE Pipe to HDPE Pipe or HDPE Fittings

HDPE pipe shall be joined to successive lengths of HDPE pipe or HDPE fittings by means of butt-fusion or sidewall fusion. Electrofusion flex restraints shall be installed per manufacturer's recommendations.

On all poly pipe fusions, it will be required to provide a quality control report that includes records of the profile of every poly fusion with all information recorded from the Datalogger. No poly pipe will be charged until these documents have been presented and verified for accuracy. All joints will be required to be numbered and will require measurements.

The Contractor shall furnish the Utility evidence, at the pre-construction meeting, that workers performing the fusion of HDPE materials have been trained in the procedure being used in accordance with the recommendations of the pipe manufacturer and the equipment manufacturer. Where sidewall fusion is to be employed, a HDPE sidewall outlet shall be used. Mechanical type taps shall not be permitted on HDPE pipe. The use of rollers during transport of HDPE pipe during installation is required by the Utility.

7. Joining of HDPE Pipe to Mechanical Joint Valves and Fittings

An MJ adapter and back-up ring shall be used to connect HDPE pipe to valves.

When butterfly valves are used, care shall be taken to ensure the full operational range of the valve disk.

When HDPE pipe is to be joined to a mechanical joint fitting, it shall be accomplished by means of a mechanical joint adapter fused to the pipe.

8. Joining of HDPE Tubing to Compression Fittings

Only 3/4"-2" HDPE pipe will be allowed to be joined by compression fittings. When connecting HDPE tubing to compression fittings, the use of a stainless-steel insert shall be used to prevent toe-in of the tubing. Only grip joint type compression fittings shall be allowed.

E. Post Installation Hydrant Flow Test

If required by the Utility, the Contractor/Developer shall request a post installation hydrant flow test to confirm the water mains provide for maximum daily demand plus fire protection flows to the respective project area. The flow test results must have a static and residual pressure of at least 20 psi.

9.10 Casing Pipe

A. General Requirement

The installation of casing pipe shall conform to these Standards and any Federal, State, Local or applicable railroad requirements, as specified in CW Standard Practice Drawing "I"-Typical Boring Casing Pipe.

| Nominal Diameter of Main | Nominal Diameter of Casing Pipe |
|--------------------------|---------------------------------|
| 4" | 10" HDPE |
| 6" | 12" HDPE |
| 8" | 16" HDPE |
| 10" | |
| 12" | 24" STEEL |
| 16" | 30" STEEL |
| 20" | 36" STEEL |
| 24" | 36" STEEL |
| 30" | 42" STEEL |
| 36" | 48" STEEL |
| 48" | 60" STEEL |

B. Carrier Pipes

PVC, polyethylene, and ductile iron are allowed. All PVC and DI joints shall be restrained, with spacers, tracing wire and all ends sealed.

C. Casing Spacers

For 4" and larger pipe, casing spacers are required every 10' or three (3) per section (one (1) at each end and one (1) in the middle).

- D. Limits of Casing (from the main to the end of casing)
1. 4' separation from edge of main to end of casing (3/4" through 1 1/4").
 2. 6' separation from edge of main to end of casing (1 1/2" through 2").
 3. 8' separation from edge of main to end of casing (4" and larger).
- E. Tracing Stations
- Tracing stations shall be installed at both ends of casing pipe and as shown in CW Standard Practice Drawing "R"-Tracing Station.
- F. Isolation of Water Main in Casing pipe
1. Valves shall be provided as designed by the Utility.
 2. Access points shall be installed within the limits of the valves to relieve possible pressure (e.g., air-relief valve, blow-off, flushing hydrant, etc.).
- G. End Seals
1. End seals shall be suitable to prevent foreign materials from entering, permit leakage to exit, and not impact the integrity of the carrier or casing pipes.
 2. The Utility reserves the right to determine the materials used to seal both ends of the casing pipe.

9.11 Stream Crossing

A. General Requirement

All stream crossing installations shall be in compliance with all sections of 327 Indiana Administrative Code (IAC) 8-3.2-10 Water mains near surface water bodies, <http://www.in.gov/legislative/iac/T03270/A00080.PDF>. In addition, the Utility has additional requirements as specified in CW Standard Practice Drawing "H"-Typical Channel Crossing. All stream crossing installations require a minimum of 54" of cover. Valves shall be provided at both ends of each crossing, unless directed by the Utility. River crossing pipe may be required by the Utility under certain conditions. Marker and posts shall be provided at both ends of crossing. Only HDPE, DI or pre-stressed concrete pipe shall be used. All joints shall be restrained.

Meter pit and permanent taps shall follow CW Standard Practice Drawing "T"-Standard Service Line Installation and Setting for 5/8", 3/4", and 1" Meter in Single Pit. Meter pit installation shall be adjacent to water main, perpendicular to valve, unless directed by the Utility.

In the event that 10' of horizontal separation between the outside edge of the water main and/or service line and the edge of the typical water line of a water body is unattainable, the installation of the water main shall conform to the guidelines set for installation of a water main under a body of water, unless directed by the Utility.

B. Installation Method

The installation of the stream crossing shall conform to the requirements of the permitting agency, be constructed in such a manner as to protect the water main from erosion and restore the stream banks and bottom to their original condition.

C. Erosion Control

The Contractor/Developer shall be responsible to ensure that each applicable construction site shall be in compliance with all the applicable sections of 327 Indiana Administrative Code (IAC) 15-5 (Rule 5).

9.12 Valves, Valve Boxes, Fittings and Blow-offs

A. Valves

Gate valves and pipe fittings shall be set and joined to new pipe in the manner specified for cleaning, laying and joining pipe herein. The Contractor/Developer shall operate each valve to confirm opening/closing functionality and orientation. Valves that do not open or close as expected or have the wrong orientation shall be replaced by the Contractor/Developer at his expense. All 16" and larger butterfly valves must be operated to determine the number of total rounds. The number counted, as well as the valve serial number must be documented accordingly. For butterfly valves installed on well lines and transmission mains, the Contractor shall install posts with the number of rounds in the valve box.

B. Valve Boxes

Cast iron valve boxes shall be firmly supported, maintained centered and plumb over the operating nut of the valve, with the box cover flush with the surface of the finished grade or at such other level as may be directed by the Utility. The valve box, if necessary, shall be supported by means of three (3) "S"-hooks hung from the top of the riser pipe to prevent the box from sliding down the riser, as specified in CW Standard Practice Drawing "G"-Standard 8" Valve Box and Cover.

C. Valve Box Riser

A solid ribbed 8" diameter PVC riser shall be required and shall be centered over the valve. If the valve is 6' deep or greater, a valve nut extension shall be provided in order to bring the operating nut to a depth, 4' below finished grade. The key nut extension shall have a centering mechanism.

D. Valves shall be supported with proper backfill and blocking so that pipe shall not be required to support the valve's weight. Valves shall be installed so that the operating stem is in a true vertical position.

9.13 Setting Meter Pits, Vaults and Hot Boxes

A. General

An inside meter setting/backflow preventer must be installed at the point of entry to the building (within 5' of the exterior wall) and must always be accessible and testable. Refer to Standard Practice Drawings T.4 or T.WF7.

All meters 1" and smaller in a commercial setting (other than jockey pump meters) must be installed outside in a meter pit; in a green space; outside of public R/W unless directed otherwise by the utility.

Meter pits, vaults and hot boxes shall be set to finished grade as specified in CW Standard Practice Drawing "S"-Standard Installation for Multiple Meter Settings and CW Standard Practice Drawing "T"-Standard Service Line Installation and Setting for 5/8", 3/4" and 1" Meter in Single Pit.

WESTFIELD – Refer to Citizens Westfield Standard Practice drawings T.WF1-6 for water meter and pit

B. Location

Interior: Meters shall be located within 5 feet of the exterior wall where the domestic service line enters the building. Any other location requires approval by the Utility.

Exterior: Meter pits, vaults and insulated/heated enclosures shall be in an easily accessible location outside of any secure areas. Meter pits and vaults shall not be installed in a traffic area or driveway unless appropriate means of protection are provided, such as concrete-filled bollards. Pits, vaults and insulated and heated enclosures shall not be installed in drainage ditches or areas prone to flooding.

C. Meter Pit Lid, Ring and Riser

The top of the meter pit lid shall be flush with finished grade.

D. Vaults

All vaults shall be equipped with a sump pit or drain opening. Vaults shall be set at finished grade. Vaults shall be installed on an 8" thick minimum granular bed of stone or gravel only.

Lids shall open in the direction from the outside to the center of the vault. The lid shall be aligned to center above of the steps or ladder.

9.14 Hydrants

A. General Location

Fire hydrants shall be placed in the field as shown on the approved plans, as specified and in CW Standard Practice Drawing "D"-Cul-de-Sac Water Main and Hydrant Installation and CW Standard Practice Drawing "E"-Cul-de-Sac Water Main with Hydrant at Intersection. Hydrants shall be installed consistent with CW

Standard Practice Drawing "B"-Standard Hydrant Setting.

Hydrants shall not be placed on the street side of the water main unless approved by the Utility.

B. Drainage at Hydrant

#8 washed stone or equivalent shall be placed below and around the base of the hydrant as shown in with CW Standard Practice Drawing "B"-Standard Hydrant Setting for 10" and Larger Water Main and CW Standard Practice Drawing "C"-Standard Hydrant Setting for 6" and 8" Water Main.

Sand shall not be used for this purpose.

C. Branch Valves

Branch valves shall be provided on every hydrant including private-owned hydrants.

D. Alignment

Hydrants shall be aligned vertically plumb. Blocking shall be installed to ensure the hydrant is not misaligned. The break-ring shall be installed within 3" of finished grade.

E. Bollards

Where hydrant protection is necessary, bollards shall be installed in accordance with the Indiana Fire Code, Section 312. See Standard Practice Drawing "O.1" – Vehicle Impact Protection for Hydrants for details.

F. Commissioning

The Contractor/Developer shall cycle each hydrant to full open and closed position to confirm orientation and functionality. Hydrants that do not open or close as expected shall be replaced by the Contractor/Developer at his expense.

9.15 Thrust Blocking

A. Design

Concrete kicker blocks and thrust blocks shall be sized for the internal static water pressure of 150 psi plus 100 psi water hammer. The thrust blocks shall be designed to allow the thrust forces in the pipeline to be borne by the adjacent soils without allowing a failure in the pipeline. For design purposes, all soils are assumed to be classified as Type C soil as defined in ASTM D2488.

B. Construction

The thrust block shall be constructed against the vertical face of undisturbed earth or sheeting left in-place. The concrete shall not encase joints or bolts in the piping.

The thrust block shall be constructed to allow the hydrant to drain.

Details and requirements for thrust blocking are shown on Standards Practice Drawing "A.2" – Thrust Blocking.

9.16 Pipe Joint Restraint Devices

Joint restraint devices shall be used at all bends and fittings in-place of thrust blocks as specified in CW Standard Practice Drawing "O"-Installation of Restraints. Joint restraint devices shall be required for the following installations:

- A. Fire Hydrants
- B. Bends
- C. Reducers
- D. Line Valves
- E. Fittings
- F. Blow-offs
- G. Dead ends

9.17 Installation of Tracing Wire and Identification Ribbon

Contractor shall install tracing wire along all pipe installations. Contractor shall install identification ribbon along all pipe installations.

- A. A minimum of one (1) tracing wire shall be laid directly on top of the water main for open cut installations. The wire shall be attached to the pipe at a maximum of 20-foot intervals.
- B. A minimum of two (2) tracing wires are required on directional bore installations of water main 4-inch diameter and larger. The wire and HDPE line shall be attached to the main at 10-foot intervals. Tracing wire on directional bores shall be one continuous piece with no splices for the entire length of the bore.
- C. The Contractor shall ensure that the tracing wire attached to the main is functional. The results of continuity test shall be documented and forwarded to the Utility. For Citizens led capital projects, the Contractor shall arrange for Citizens Water Operations staff to perform the continuity test. All said activities shall be conducted after the main installation has been completed and prior to final connection. If additional continuity testing is required, the Developer shall be required to pay all related costs on a time and material basis. The project will not be released for service connection until continuity testing has been properly demonstrated and documented to the Utility.
- D. At each valve and hydrant, the tracing wire shall be brought to the point as specified herein. At hydrants, the tracing wire shall be connected to the test station as specified in Section 7.17 C. The tracing wire shall be attached to the hydrant barrel as it is inserted into the test station. At valves, the tracing wire shall be brought to 18" below grade on the outside of the riser. A 1/2" diameter hole shall be cut in the side of the riser and the tracing wire looped and knotted on the inside of the riser to keep the tracing wire at this elevation. A minimum 24" loop of tracing wire shall be left inside of the valve box riser. The tracing wire shall continue down the valve box in a continuous run to the pipe on the opposite side of the valve.
- D. A tracing station shall be provided at all changes from metallic to non-metallic (including concrete) pipe where there is not a hydrant or valve adjacent to the

transition, as specified in CW Standard Practice Drawing "R"-Tracing Station.

- E. The tracing wire shall be made continuous by use of connections. These connections shall be made with a water-tight silicone-filled connector. See Sections 7.17 or 8.18 for specifications. Where all coupling connections are made in the tracing wire, an overhand loop knot shall be made to prevent the coupling from being pulled apart. The connections shall be taped with electrical moisture sealant patches.
- F. If the trench is less than 2' wide, the Contractor shall install an identification ribbon to the side of the ditch wall with staples at 10-foot intervals, 1' to 2' below grade.
- G. If the trench is wider than 2' wide, the Contractor shall install an identification ribbon directly over the water main at a depth of 24" below finished grade and maintain location during backfilling procedures.
- H. In paved areas, the ribbon shall be installed directly under the pavement base.

9.18 Polyethylene Wrap

- A. Polyethylene wrap shall be installed in accordance with AWWA C105. Cross-laminated 4 mil polyethylene wrap for DI main installation shall be cut 2' longer than a standard length of pipe. The tube shall be slipped over the pipe and centered to allow 1' of overlap on each adjacent pipe section. After the lap is made, the slack in the tubing shall be taken up for a snug fit, and the overlay shall be secured with a polyethylene tape, as described in Section 7.15, "Polyethylene Encasement".
- B. All metallic appurtenances shall be encased in polyethylene and all seams and joints shall be secured with polyethylene tape.
- C. The Contractor/Developer shall repair and/or replace the polyethylene wrap, whenever any modifications are made to the main.

9.19 Charging, Flushing, Air Removal and Hydrostatic Testing

The water main and service lines for commercial and industrial customers shall be charged with water from an existing Utility facility, as directed by the Utility. The Contractor shall conduct the flushing, air removal and hydrostatic testing as specified in Appendix C-Construction Testing Methods.

9.20 Disinfection of Water Mains and Service Lines

- A. Disinfection

All pipe installed by a contractor shall be disinfected in accordance with AWWA C651 and all applicable Federal, State and Local requirements. The disinfection process shall be conducted as specified in Appendix C-Construction Testing Methods. If required, the trench/point(s) of access shall be prepared in such a manner as to comply with all applicable OSHA regulations and as directed by the Utility.

The chlorination point and supply shall be accessible above grade.

B. Bacteriological Samples

The Utility will collect water samples for bacteriological testing. The main will not be approved for final connection to the existing distribution system until sampling results are obtained and approved by the Utility.

Sampling requirements for service lines 2" and larger shall be conducted consistent with AWWA C651.

9.21 Connection with Existing Distribution System

A. General Information

The Contractor shall connect the water main(s) and/or service line(s) to the existing distribution system as directed by the Utility, in order to flush the new main. The final connection shall be performed in the presence of the Utility.

Any existing appurtenances (e.g., valves, blow-off assemblies, etc.) shall be operated by the Utility only. If final connection has not been completed within 60 days after sterilization, the main shall be disinfected, as described herein before final connection will be authorized by the Utility.

If a new connection is the same pipe diameter as the existing water main, the Utility or its approved contractor will install a cut-in tee to protect the integrity of the distribution system. Ductile iron main will be the only exception, all size-on-size tap connections on cast iron, polyethylene and PVC will require cut in tees.

B. Removing Existing Plugs for Connections

To assure that all the pressure is off the main, the Utility will open the closest hydrant, blow-off assembly or service line. If there is no means of checking for pressure, a 3/4" tap shall be installed by the Contractor on the top of the main adjacent to the plug to be removed.

C. Main Connection

The dewatering of the main connection shall be properly completed to avoid contamination of new and existing mains.

The main connections shall be completed within a 12-hour period, without interruption.

D. Customer Notification

All customers potentially affected by a temporary interruption of water service shall receive a notification of the pending interruption as described in Section 9.01. C.

E. Connection with Existing Services

The Contractor/Developer may not connect a new service line to any existing pipe unless directed by the Utility. The Contractor/Developer shall schedule the service connection at a minimum of 24-hour advance notice. The service

connection shall not be backfilled without being inspected and approved by the Utility.

WESTFIELD- Shall utilize the following website for scheduling service connections- <https://www.citizensenergygroup.com/For-Partners/Contractors-Builders/Permits-and-Forms>

9.22 Restoration

A. General

The following standards represent the minimum restoration requirements. Local jurisdiction requirements will prevail if more specific/stringent local codes exist. The Contractor/Developer shall be aware of the requirements specified in the City of Indianapolis, Department of Metropolitan Development, Regulations for Cuts within the Public Right-of-Way (INDOT Regulations).

The Utility shall inspect the restoration within 30 days of completion of work. The Contractor/Developer shall correct all deficiencies within two (2) weeks of notification.

B. General Requirements

1. Remove trash (rags, boards, metal bands, downed tree limbs, etc.), construction debris, large dirt clumps, rocks, etc. prior to starting restoration work.
2. Establish proper drainage between driveways culverts, and drainage ditches in disturbed areas.
3. Adjust all water main valve boxes, curb boxes, meter pits, and vaults to grade.
4. Visually inspect all restoration every six (6) months and repair as necessary repairs through the maintenance bond period.

C. Established Lawns

1. Place a minimum of six (6) inches of topsoil to promote grass germination.
2. Apply seed, fertilizer, and straw in sufficient quantity to germinate the grass. The Contractor/Developer shall be responsible to re-seed any area that does not achieve 75 percent re-growth.
3. For an area with a slope is greater than 3 to 1 or previously used sod, restore with new sod or with straw mat.

D. Open Fields

1. Grade the area as required to match existing terrain. Avoid interrupting the natural drainage of the area.
2. Apply seed and straw as required to promote grass germination.

E. Sidewalks

1. Repair concrete sidewalks and driveway approaches removed or damaged during construction.
2. Make concrete cuts at a panel joint to a depth of one-third of the sidewalk. A minimum saw-cut of two (2) inches is required. The cut shall then be completed with a mechanical hammer equipped with a suitable chisel and start from the center of the cut. Dispose of cut panels.
3. Partial panel restoration is not permitted.
4. Protect new concrete with a membrane type-curing compound and from

traffic for a minimum of 48 hours.

F. Concrete Streets and Alleys

1. Make full depth saw cuts to remove pavement damaged during construction or that needs replaced. Make cuts at the pavement joints where possible. Partial panels may be cut in 10-foot sections per the discretion of DOT and their regulations.
2. Use high early strength pavement as required by current DOT Regulations.
3. Place a minimum thickness of six (6) inches or match the existing road thickness.
4. For reinforced concrete, repair or replace as follows:
 - Use in kind steel reinforcement and temporarily bend back the existing reinforcement steel out of the way. When the concrete is replaced, properly fastened to the adjacent reinforcement.
 - Drill and grout number 5 bars two (2) feet long into the existing pavement sides one (1) foot deep at two (2) foot center-to-center facing with a minimum of two (2) bars per side.
5. Protect new concrete with a membrane type curing compound.
6. Protect new concrete from traffic for a minimum of 48 hours by using steel plates, barrels and arrow board as needed.
 - Use steel plates with a minimum thickness of 3/4 inch and secure to prevent movement and not create a hazard when the road is open to traffic.
 - Refer to DOT Regulations for arrow board requirements.
 - Use barrels to protect an arrow board left over night and to direct the traffic flow. Barrels must have a flashing light on any of the tapered sections per DOT Regulations.

G. Asphalt Streets and Alleys

1. Minimum pavement thicknesses for streets are:
 - Class I: 12 inches
 - Class II: 12 inches
 - Class III 7 inchesMatch existing pavement thickness if it exceeds the depths listed above.
2. Use a hot asphalt mix or multi-grade cold mix placed in four (4) inch lifts for the base material and compact by rolling or other methods to achieve compaction. A concrete cap can also be used as the base material.
3. Place one and one half (1-1/2) inches of hot asphalt surface on top of the base material.
4. Thoroughly clean and tack coat edges or joints of existing pavement prior to placing the hot asphalt surface.
Maintenance.

- H. Upon completion of the project, the Contractor/Developer shall maintain the surfaces of curbs and gutters, paved surfaces, sidewalks, and grass areas for a period of three (3) years thereafter, or for such greater period as may be required by Federal, State or Local authorities.

In unpaved areas, the Contractor/Developer shall maintain the surface of the disturbed trench area for a minimum of three (3) years after completion of the project. Any settling of the trench below the grade of the adjacent undisturbed areas shall be corrected by bringing additional topsoil in to raise the trench surface to the same level as the adjacent ground. Reseeding of these raised areas shall be performed in order to provide a uniform finished surface

9.23 Additional Items

- A. All water used on a project shall be metered. Only hydrant wrenches shall be used for opening and closing fire hydrants. In no case shall pipe wrenches be used for this purpose.
- B. The condition of the jobsite is the responsibility of the Contractor/Developer. Debris and rubbish material shall become the property of the Contractor/Developer and it shall be the Contractor/Developer's responsibility to dispose of such material.
- C. The Contractor/Developer shall be responsible for scheduling all hydrostatic tests, initial connections and final connections. Should the Contractor/Developer cancel and reschedule these procedures and cause additional costs to the Utility in doing so, the Contractor/Developer shall be responsible for all corresponding costs.

9.24 Construction Record Measurements

Construction records of all water main installations and appurtenances shall be made during and after construction of the project and provided to the Utility.

Construction record measurements shall be made according to the following criteria:

- A. Offset measurements shall be made to all fittings, valves, blow-off assemblies, hydrants, and other appurtenances. The first measurement shall be made from the centerline of the nearest street running parallel to the installed water main, thence perpendicular to the centerline of the appurtenance on that water main. The second or cross-measurement shall be made from the nearest centerline of a street running in a perpendicular or near perpendicular direction to the water main, thence perpendicular to the centerline of the appurtenance. Should a nearby street not be available for reference measurement, a permanent structure may be used and referenced to another permanent structure or street intersection or centerline.
- B. All installed pipe sizes shall be listed, and the length measured along the centerline of the pipe.
- C. All materials manufacturer information shall be listed.
- D. All easement locations, types, and dimensions shall be included.
- E. Projects utilizing fusing, all Datalogger information in the correct format.
- F. Locations, material, and sizes of all service lines exposed during construction activities, including information upstream and downstream of any connection points.
- G. Location including length and width of contaminated soil shall be included.
- H. For GPS-related information, refer to Appendix B-Water Distribution Plans.
- I. All records to be submitted to: Citizens Water, 2150 Dr. Martin Luther King Jr. Drive, Indianapolis, IN 46202.

9.25 Dry Main Installation

The installation of a dry main shall adhere to all applicable subsections of Section 9.0-Construction Methods for Water Main Installation including the following requirements.

- A. A dry main installation project shall require a separate contract and maintenance bond.
- B. The Contractor/Developer must contact your respective Construction Inspector for the project to coordinate installation of the dry mains. In addition, please complete the "Request for Dry Main Installation Form (11-7-14)".
- C. All materials for the dry water main crossing must be onsite for a preconstruction meeting to be held onsite and shall be coordinated with the Construction Inspector.
- D. The Construction Inspector must be notified 24hrs in advance of the preconstruction meeting.
- E. All dry mains shall be subject to all applicable inspection fees.
- F. Dry mains shall be constructed with the same material designed for the rest of project.
- G. The start and ending points shall be closed using a mechanical joint plug or fusible mechanical joint connection (commonly referred to as a "Harvey Connection") if installing HDPE pipe.
- H. An access point shall be installed at the starting and ending points of the dry main to relieve possible pressure and for accessing of tracing wire (e.g., blow-off, flushing hydrant, etc.).
- I. All connections to a dry main shall be inspected by the Utility during the construction of the connection.
- J. The dry mains must always maintain proper cover.
- K. The Contractor/Developer must complete all remaining work to connecting water mains within 30 days of the installation of the dry water main crossing unless otherwise authorized.
- L. The Contractor/Developer must provide a copy of the most current project drawing depicting where dry main installations are requested and showing main size and fittings.
- M. The Contractor/Developer is responsible for all dry water main crossings installed prior to final approval of water main plans by the Utility.

9.26 Water Main/Service Line Repairs on Warranted Work

- A. Materials

The Contractor/Developer shall be responsible for repairing or replacing failed materials in accordance with the requirements of these Standards for a period of

three (3) years after the in-service date.

B. Workmanship

The Contractor/Developer shall be responsible for the repair of service line failures due to faulty workmanship in accordance with the requirements of these Standards including testing. There shall be no time constraint for repairs due to faulty workmanship.

When a customer is out-of-service due to a failure, the Contractor/Developer shall supply the customer with temporary water service until repairs are complete.

The repairs shall be completed within a 24-hour period, unless approved by Utility.

If the necessary repairs are not completed within 72 hours, the Utility shall make the repairs at the Contractor/Developer's cost.

9.27 Water Main/Service Line Safety Issues

The Contractor/Developer shall be required to comply with all applicable safety standards.

A. Traffic Control

The Contractor/Developer shall provide traffic control as required by Federal, State or Local authorities.

B. Support of Existing Utilities and Structures

The Contractor/Developer shall protect, support and adequately maintain all existing utilities, structures, drains, sewers and other obstructions encountered during project installation. The Contractor/Developer shall furnish these items at their own expense.

The Contractor/Developer shall immediately notify the owner of any damage made to their facilities. Such damage shall be repaired in accordance with the directive, and to the satisfaction, of the directing owner. All repairs shall be at the Contractor/Developer's expense.

C. Hazardous Atmosphere

It shall be the responsibility of the Contractor/Developer to comply with all Federal, State and Local requirements when working in environments that may expose them to hazardous atmospheres.

D. Safety Chains and Backhoe Hooks

All safety chains and backhoe hooks shall be OSHA approved.

E. Competent Person On-Site

The Contractor/Developer shall be responsible for having a competent person on-site for the duration of the work being performed.

- F. The Utility will not perform any required work, until all applicable safety conditions are met. The Utility shall be reimbursed for all costs corresponding to any additional work.

END OF SECTION

APPENDIX A- Abbreviations and Definitions

A. Abbreviations

A

ANSI - American National Standards Institute
ASTM - American Society of Testing and Materials
AWWA - American Water Works Association

B

B.O., Temporary - Blow-Off Assembly

C

CI - Cast Iron
CW- Citizens Water

D

DCA - Double Check Valve Assembly
DCDA- Double Check Detector Assembly
DI - Ductile Iron
DIPRA - Ductile Iron Pipe Research Association
DIPS- Ductile Iron Pipe Size
DPW – City of Indianapolis Department of Public Works
DR - Dimension Ratio

F

FIP - Female Iron Pipe

G

GPS – Global Positioning System
GIS– Geographic Information System

H

HDPE- High-Density Polyethylene

I

ID - Inside Diameter
IDNR - Indiana Department of Natural Resources
IDEM - Indiana Department of Environmental Management
ILC - Irrevocable Letter of Credit
INDOT - Indiana Department of Transportation
IURC - Indiana Utility Regulatory Commission

M

MJ - Mechanical Joint

N

NC - National Course Thread
NOI - Notice of Intent
NPT - National Pipe Thread
NSF - National Sanitation Foundation
NST - National Standard Thread

O

OD - Outside Diameter
OSHA - Occupational Safety and Health Administration

P

PDOP - Position Dilution of Precision
PE - Polyethylene
PE - Professional Engineer
PL - Property Line
PJ - Push-on Joint
PSF - pounds per square foot
PSI - pounds per square inch
PVC - Polyvinyl Chloride

R

RPDA - Reduced Pressure Zone Detector Assembly
RPZ – Reduced Pressure Zone Assembly
R/W - Right-of-Way

S

SDR - Standard Diameter Ratio

T

TPI- Threads per Inch

W

WOG - water, oil, gas

B. Definitions

C

Contractor - Any Contractor who meets the Utility's requirements to perform the work of installing water lines under the Utility's jurisdiction.

D

Design Engineer - The Professional Engineer licensed in the state of Indiana responsible for the engineering design of the proposed water main extension.

Developer - Any person, association, corporation, entity, or government agency desiring water service for premises under their control.

Disinfection- A process to eliminate the presence of coliform bacteria

Distribution System - The collection of water mains interconnected to form a system of pipes, valves, hydrants, and appurtenances that can safely transport potable water from the Company's treatment facilities to the individual customers throughout the service area.

I

Inspector - The authorized representative of Citizens Water.

M

Main Extension - extension of the distribution system that will serve new customers

O

Obstruction- An obstacle constructed, located, or positioned in such a way that it prohibits or impedes reasonable access, ingress and/or egress, to water system facilities.

S

Service Line – water line tapped into a Company water main to serve a customer of the Company, including private hydrants and other appurtenances.

T

Ten State Standards - The Recommended Standards for Water Works, most recent edition, as published by the Great Lakes Upper Mississippi River Board of State Public Health and Environmental Managers.

Transmission Main – Pipes together with all appurtenances, valves, fire hydrants, and associated materials designed to convey potable water from a treatment plant directly to a bleeder valve, booster pump station or similar facility. These mains are not directly connected to the distribution system and/or service lines.

U

Utility – Means Citizens Water and/or its contract operator.

W

Water Main - Pipes of 3-inch and larger diameter, together with all appurtenances, valves, fire hydrants, and associated materials designed to receive potable water and distribute it to individual customers of the Utility.

Well Lines – Pipes together with all appurtenances, valves, fire hydrants, and associated materials designed to convey non-potable water from a wellfield to treatment plant.

APPENDIX B- Water Distribution Plans

A. General

All required submittals must be delivered to the Utility as one (1) complete submittal package. If the submittals do not meet the specified requirements, the Developer or their subcontractors shall be required to pay any costs associated with the additional approval process. Said cost shall be on a time and material basis and shall be paid to the Utility's authorized representatives.

Also, if the Developer or their subcontractors submit changes to the already approved final project drawings or any part of the engineering submittal, the Developer or their subcontractors shall be required to pay any costs associated with the additional approval process. Said cost shall be on a time and material basis and shall be paid to the Utility.

B. Software Requirements

All listed drafting standards and parameters are based on AutoCAD. Regardless, if the Developer or Design Engineer uses different software to produce the submittals, a one- to-one conversion to AutoCAD must be submitted to the Utility.

C. Digital Registration

All drawing elements shall be submitted referencing Indiana East State Plane Coordinates, or as approved by the Utility. Elements referencing Indiana East State Plane Coordinates will utilize the North American Datum of 1983 (NAD83) for horizontal control and be measured in US Survey Foot Feed (not international Foot).

D. Department Standards

The Utility's authorized representative shall provide an AutoCAD drawing via email with submittal information that could be used by the Design Engineer. The following describes the contents of this template:

1. Blocks of various fittings, text blocks and appurtenances
2. Other parameters included and made specific to each drawing base:
 - a) Layer Control
 - b) Line Types
 - c) Text styles with appropriate text heights

E. Paper/Model Space

The "Paper Space/Model Space" shall be required on all digital drawing submittals.

F. *base100.dwg* (Overall Development Plan, Preliminary Plat and Final Plat)

The edges of the sheet are initially set at 24"x36" but may be manipulated (stretched) to adapt to a larger/smaller sheet size if so desired as long as the maximum/minimum sheet size allowances established in these standards is met. The base sheet is pre- scaled to 1"=100'.

G. base50.dwg (Plan Base Sheet)

The edges of the sheet are initially set at 24"x36" to satisfy the sheet size allowance as prescribed in these standards. The base sheet is pre-scaled to 1"=50'.

H. ppbase50.dwg (Plan and Profile Base Sheet)

The Plan and Profile Base Sheet, *ppbase50.dwg*, provided on the available CD and contains all the necessary items for the submittal of the Final Construction Plans where Plan and Profiles are required. This sheet could also be required where a stream crossing, excessive change in grade, or other project specific features necessitate the inclusion of a profile of the water main in the plans.

The edges of this sheet are currently set at 24"x36" to satisfy the sheet size allowance as prescribed in these standards. This base sheet is pre-scaled to 1"=50'. However, the horizontal scale in the profile is pre-scaled to 1"=50' horizontal and 1"=5' vertical.

I. Line Work

All line work associated with the water mains, rights-of-way, centerlines, and easements shall be performed using "POLYLINES". See "Layer Control" for additional detailed information.

Water main lines shall be drawn from the insertion point of a block (fitting, valve, or hydrant) to the insertion point of another block. Each segment between two (2) blocks must be a separate polyline and all blocks must be connected.

J. Blocks

All blocks shall be brought into the appropriate layers (see "Layer Control"). The blocks and associative information are as follows:

1. Blocks associated with piping shall be inserted on the proper layer, rotated to the correct position and left unexploded. The blocks listed below shall be placed in "Model Space".

| Description | Drawing File Name |
|--------------------|---------------------|
| Tee | <i>tee.dwg</i> |
| Cross | <i>cross.dwg</i> |
| Reducer | <i>reducer.dwg</i> |
| 90-Degree Bend | <i>bend90d.dwg</i> |
| 45-Degree Bend | <i>bend45.dwg</i> |
| 22 ½ - Degree Bend | <i>bend225.dwg</i> |
| 11 ¼ - Degree Bend | <i>bend1125.dwg</i> |
| Gate Valve | <i>valveg.dwg</i> |
| Butterfly Valve | <i>valveb.dwg</i> |
| Air Relief | <i>airrelf.dwg</i> |
| Hydrant | <i>hydrant.dwg</i> |
| Hydrant with Valve | <i>hydvlv.dwg</i> |
| Blow-Off Assembly | <i>blowoff.dwg</i> |
| Plug | <i>plug.dwg</i> |
| Kicker Block | <i>kicker.dwg</i> |
| Adapter | <i>adapter.dwg</i> |
| Tracing Station | <i>TracStat.dwg</i> |

2. Piping, Parcel and Easement Information

| Description | Drawing File Name |
|-----------------------|--------------------------|
| Pipe Job Notes | <i>PipeJobN.dwg</i> |
| Parcel Identification | <i>Parcelid_2009.dwg</i> |
| Easement Information | <i>Esmtinfo.dwg</i> |

Pipe Job Notes

- i. Project Number (Utility J-number)
- ii. Primary Street Name
- iii. Job Number
- iv. Pipe Material – include list of type
- v. Pipe Size
- vi. Length of Main

Parcel Information

- i. Project Number (Utility J-Number)
- ii. Lot Number
- iii. House Number
- iv. Direction
- v. Street Name
- vi. Street Suffix
- vii. Street Suffix Direction
- viii. Apt / Unit / Suite
- ix. Pipe Size
- x. Pipe Material
- xi. Key Number (Utility Assigned)
- xii. Second House Number (Corner Lots)
- xiii. Second Direction (Corner Lots)
- xiv. Second Street Name (Corner Lots)
- xv. Second Street Suffix (Corner Lots)
- xvi. Second Street Suffix Direction (Corner Lots)
- xvii. Second Pipe Size (Corner Lots)
- xviii. Second Pipe Material (Corner Lots)

Easement Information

- i. Easement Size
- ii. Easement Type (exclusive or non-exclusive)
- iii. If granted, Drawing Number

3. GPS System use provides additional information. Should the Developer/Engineer use GPS to capture locations of facilities, the Utility's data dictionary for Trimble equipment is available. The following blocks should be used:

| Description | Drawing File Name |
|--------------------|--------------------------|
| Hydrant | <i>GPS_FH.dwg</i> |
| Fitting | <i>GPS_F.dwg</i> |
| Valve | <i>GPS_V.dwg</i> |

In addition to the previously described attributes, GPS specific attributes will be associated with each of the above blocks for materials inventory/accounting and future Record Drawing information. The attributes will contain specific items, such as:

- i. Height
- ii. Date of Capture
- iii. Time of Capture
- iv. Maximum PDOP at time of Capture
- v. Vertical Precision
- vi. Horizontal Precision
- vii. Standard Deviation of Position
- viii. GPS Receive Type/Model
- ix. Correction Type

4. Information blocks not associated with piping shall be inserted on the “TITLE” layer in “Paper Space”, rotated to the correct position (if applicable). All information required in the blocks shall be completed by the Developer/Engineer.

| Description | Job Use | Drawing File Name |
|-------------------------|----------------|--------------------------|
| Project Information | | <i>ProjInfo.dwg</i> |
| Location Map | | <i>Locatmap.dwg</i> |
| CEG Project Legend | 'J' Jobs Only | <i>CEGProjLeg.dwg</i> |
| CEG Project Information | Non 'J' Jobs | <i>CEGProjInfo.dwg</i> |

Project Information – Unexploded

- i. Project Name
- ii. Project Number (Utility Assigned)
- iii. Distribution map No (Utility Assigned)
- iv. Meter Map No (Utility Assigned)
- v. Number of Lots
- vi. Tax Code (Utility Assigned)
- vii. County (Utility Assigned)
- viii. Township (Utility Assigned)
- ix. Sewer Provider (Utility Assigned)
- x. Pressure District (Utility Assigned)
- xi. Drafted By
- xii. Submittal Date, Revision History

Location Map – Unexploded

- i. The Project Name and Number shall be modified for the current project.
- ii. Each unique Street Name / Pipe Size / Pipe Type shall have its own row.
- iii. Project pipe length total shall be shown in the last row.
- iv. The CEG project legend can be lengthened as needed.
- v. The Project Number shall be modified for the current project.
- vi. Each unique Activity shall have its own row.
- vii. The CEG Project Information can be lengthened as needed.

5. Additional information blocks not associated with piping shall be inserted on the “TITLE” layer in “Paper Space”, rotated to the correct position (if applicable) and left unexploded.

| Description | Drawing File Name |
|--|--------------------------|
| North Arrow | <i>narrow.dwg</i> |
| Indiana Underground Protection Service (Holey Moley) | <i>moley.dwg</i> |
| Legend | <i>legend.dwg</i> |

6. Other blocks shall be inserted on their associative layers in “Model Space”, and rotated to the correct position (if applicable), and left unexploded. The Design Engineer shall add all information required in these blocks.

| Description | Drawing File Name |
|------------------|--------------------|
| Job No. Note | <i>jobnote.dwg</i> |
| Hydrant No. Note | <i>hydnote.dwg</i> |

The attributes associated with the above blocks require specific information provided by the Design Engineer.

K. Layer Control

The following layer control tables are included in the individual drawings on the provided CD. All items included in the proposed development shall be placed on the appropriate layer in the proposed layer table. The existing layer table is provided as a reference, and it is suggested that all items not pertaining to the proposed development be placed on these layers. Should an entity not be listed in the table below, do not assume that it belongs in the layers listed; a new layer for that entity should be created.

Proposed Layers

| Description | Layer Name | Preferred Color | Line Type | Entity Type | Tile Mode |
|-----------------------------------|-------------|-----------------|------------|------------------|-----------|
| Proposed 3” Pipe | P3IN | White | Hidden | Polyline | Model |
| Proposed 6” Pipe | P6IN | Yellow | Hidden | Polyline | Model |
| Proposed 8” Pipe | P8IN | Green | Hidden | Polyline | Model |
| Proposed 12” Pipe | P12IN | Red | Hidden | Polyline | Model |
| Proposed 16” Pipe | P16IN | 14 | Hidden | Polyline | Model |
| Proposed 20” Pipe | P20IN | Magenta | Hidden | Polyline | Model |
| Proposed 24” Pipe | P24IN | Cyan | Hidden | Polyline | Model |
| Proposed .75” Service Line | PS.75IN | White | Hidden | Polyline | Model |
| Proposed 1” Service Line | PS1IN | White | Hidden | Polyline | Model |
| Proposed 1.25” Service Line | PS1.25IN | White | Hidden | Polyline | Model |
| Proposed 1.5” Service Line | PS1.5IN | White | Hidden | Polyline | Model |
| Proposed 2” Service Line | PS2IN | White | Hidden | Polyline | Model |
| Proposed 4” Service Line | PS4IN | White | Hidden | Polyline | Model |
| Proposed 6” Service Line | PS6IN | Yellow | Hidden | Polyline | Model |
| Proposed 8” Service Line | PS8IN | Green | Hidden | Polyline | Model |
| Proposed 10” Service Line | PS10IN | Red | Hidden | Polyline | Model |
| Proposed 12” Service Line | PS12IN | Red/White | Hidden | Polyline | Model |
| Proposed 16” Service Line | PS16IN | 10White | Hidden | Polyline | Model |
| Pipe Job Notes | PipeJobN | | | Block | Model |
| Proposed Fittings | PFITTING | Green | Continuous | Block | Model |
| Proposed Valve | PV | Yellow | Continuous | Block | Model |
| Proposed Major Contours (5’, 10’) | PCONT_MAJOR | | | | |
| Proposed Minor Contours (1’, 2’) | PCONT_MINOR | | | | |
| Proposed Profile | PPROFILE | | | | |
| Proposed Service | PSERV | White | Continuous | Polyline or Line | Model |
| Proposed Hydrants | PFH | Red | Continuous | Block | Model |
| Proposed Casing/Boring | PCASING | Yellow | Continuous | Polyline | Model |
| Proposed D&U Easement | PESMT | | | Polyline | Model |
| Proposed Right-of-Way | PRW | | | Polyline | Model |
| Proposed Centerline | PWCL | | | Polyline | Model |
| Proposed Improved Roads | PRoad_I | | | Polyline or Line | Model |
| Proposed Back of Curb | PCurbB | | | Polyline or Line | Model |
| Proposed Front of Curb | PCurbF | | | Polyline or Line | Model |
| Proposed River | PRiver | | | Polyline or Line | Model |
| Proposed Pond | PPond | | | Polyline or Line | Model |

| | | | | | |
|---|-------------|---------|--|------------------|-------|
| Proposed Subdivision Boundary | PSub_B | | | Polyline | Model |
| Proposed Subdivision Name | PSub_N | | | N/A | Model |
| Proposed House Numbers | PHse_num | | | N/A | Model |
| Proposed Parcel Identification | PPID | | | Block | Model |
| Proposed Property Lines | PPL | | | Polyline or Line | Model |
| Proposed Lot Numbers | Plot | | | N/A | Model |
| Proposed Street Names | PSt_Name | | | N/A | Model |
| Proposed Bridge | PBridge | | | Polyline or Line | Model |
| Proposed Building | PBldg | | | Polyline or Line | Model |
| Proposed Paved Parking | PPrk_P | | | Polyline or Line | Model |
| Proposed Sanitary Sewers | PSan | | | Polyline | Model |
| Proposed Storm Sewers | Psew | | | Polyline | Model |
| Proposed Buried Gas Lines | PUGG | | | Polyline | Model |
| Proposed Buried Electric | PUGE | | | Polyline | Model |
| Proposed Buried Telephone | PUGT | | | Polyline | Model |
| Proposed Buried Fiber Optics | PUGF | | | Polyline | Model |
| Proposed Buried Cable TV | PUGCTV | | | Polyline | Model |
| Proposed Overhead Electric | POHE | | | Polyline | Model |
| Proposed Overhead Telephone | POHT | | | Polyline | Model |
| Proposed Overhead Fiber Optics | POHF | | | Polyline | Model |
| Proposed Overhead Cable TV | POHCTV | | | Polyline | Model |
| Hydrant No. Note, Job No. Note | JOBNOTES | (as is) | | Blocks | Model |
| North Arrow, Holey Moley, Project Description Note, Legend, Location Map, Title Block | TITLE | (as is) | | Blocks | Paper |
| IWCW Easement Boundary | ESMTIWCWC | | | Polyline | Model |
| IWCW Easement Tie | ESMTTIE | | | Polyline | Model |
| IWCW Easement Centerline | ESMTCL | | | Polyline | Model |
| IWCW Easement Chord | ESMTCHRD | | | Polyline | Model |
| IWCW Easement Text | ESMTTEXT | | | Text | Model |
| IWCW Easement Info (Block) | IWCWCESMTID | | | Block | Model |

Existing Layers

| Description | Layer Name | Preferred Color | Line Type | Entity Type | Tile Mode |
|------------------------|------------|-----------------|------------|-------------|-----------|
| Ex. 1" Pipe | E1IN | White | Continuous | Polyline | Model |
| Ex. 2" Pipe | E2IN | White | Continuous | Polyline | Model |
| Ex. 3" Pipe | E3IN | White | Continuous | Polyline | Model |
| Ex. 4" Pipe | E4IN | White | Continuous | Polyline | Model |
| Ex. 6" Pipe | E6IN | Yellow | Continuous | Polyline | Model |
| Ex. 8" Pipe | E8IN | Green | Continuous | Polyline | Model |
| Ex. 10" Pipe | E10IN | Red | Continuous | Polyline | Model |
| Ex. 12" Pipe | E12IN | Red | Continuous | Polyline | Model |
| Ex. 16" Pipe | E16IN | 14 | Continuous | Polyline | Model |
| Ex. 20" Pipe | E20IN | Magenta | Continuous | Polyline | Model |
| Ex. 24" Pipe | E24IN | Magenta | Continuous | Polyline | Model |
| Ex. 30" Pipe | E30IN | Magenta | Continuous | Polyline | Model |
| Ex. 36" Pipe | E36IN | Magenta | Continuous | Polyline | Model |
| Ex. 42" Pipe | E42IN | 20 | Continuous | Polyline | Model |
| Ex. 48" Pipe | E48IN | 20 | Continuous | Polyline | Model |
| Ex. .75" Service Line | ES.75IN | White | Continuous | Polyline | Model |
| Ex. 1" Service Line | ES1IN | White | Continuous | Polyline | Model |
| Ex. 1.25" Service Line | ES1.25IN | White | Continuous | Polyline | Model |
| Ex. 1.5" Service Line | ES1.5IN | White | Continuous | Polyline | Model |
| Ex. 2" Service Line | ES2IN | White | Continuous | Polyline | Model |
| Ex. 4" Service Line | ES4IN | White | Continuous | Polyline | Model |
| Ex. 6" Service Line | ES6IN | Yellow | Continuous | Polyline | Model |
| Ex. 8" Service Line | ES8IN | Green | Continuous | Polyline | Model |
| Ex. 10" Service Line | ES10IN | Red | Continuous | Polyline | Model |
| Ex. 12" Service Line | ES12IN | Red | Continuous | Polyline | Model |
| Ex. 16" Service Line | ES16IN | 10 | Continuous | Polyline | Model |

| | | | | | |
|--|-------------|----------|------------|------------------|-------|
| Ex. Fittings (bends, tees, reducers, etc.) | EFitting | White | Continuous | Block | Model |
| Ex. Valves | EV | White | Continuous | Block | Model |
| Ex. Hydrants | EFH | White | Continuous | Block | Model |
| Ex. Company Easement | EEsmtCWc | Green | Continuous | Polyline | Model |
| Ex. Major Contours (5', 10') | ECONT MAJOR | | | | |
| Ex. Minor Contours (1', 2') | ECONT MINOR | | | | |
| Ex. Profile Grade | EPGrade | 15 | Phantom | Polyline | Model |
| Ex. Easement (Drainage & Utility) | Eesmt | Blue | Dashed | Polyline | Model |
| Ex. Right-of-Way | ERW | White | Continuous | Polyline | Model |
| Ex. Centerline | EWCL | 14 | Centerline | Polyline | Model |
| Ex. Improved Roads | ERoad I | Blue | Continuous | Polyline or Line | Model |
| Ex. Back of Curb | ECurbB | | | Polyline or Line | Model |
| Ex. Front of Curb | ECurbF | | | Polyline or Line | Model |
| Ex. River | ERiver | Cyan | Phantom | Polyline or Line | Model |
| Ex. Pond | EPond | Cyan | Phantom | Polyline or Line | Model |
| Ex. Profile | EProfile | | | | |
| Ex. Lake | ELake | Cyan | Phantom | Polyline or Line | Model |
| Ex. Railroad | ERR | White | Dashed | Polyline or Line | Model |
| Ex. Subdivision Boundary | ESub_B | 15 | Border | Polyline | Model |
| Ex. Subdivision name | ESub_N | White | Continuous | N/A | Model |
| Ex. House Numbers | EHse_num | Lt. Gray | Continuous | N/A | Model |
| Ex. Property Lines | EPL | 15 | Phantom | Polyline or Line | Model |
| Ex. Lot Numbers | ELot | 12 | Continuous | N/A | Model |
| Ex. Street Names | Est_Name | Red | Continuous | N/A | Model |
| Ex. Bridge | EBridge | 12 | Continuous | Polyline or Line | Model |
| Ex. Building | EBldg | 12 | Continuous | Polyline or Line | Model |
| Ex. Paved Parking | EPrk_P | Blue | Dashed | Polyline or Line | Model |
| Ex. Sanitary Sewers | ESan | | | Polyline or Line | Model |
| Ex. Storm Sewers | ESew | | | Polyline or Line | Model |
| Ex. Buried Gas Lines | EUGG | | | Polyline | Model |
| Ex. Buried Electric | EUGE | | | Polyline | Model |
| Ex. Buried Telephone | EUGT | | | Polyline | Model |
| Ex. Buried Fiber Optics | EUGF | | | Polyline | Model |
| Ex. Buried Cable TV | EUGCTV | | | Polyline | Model |
| Ex. Overhead Gas Lines | EOHG | | | Polyline | Model |
| Ex. Overhead Electric | EOHE | | | Polyline | Model |
| Ex. Overhead Telephone | EOHT | | | Polyline | Model |
| Ex. Overhead Fiber Optics | EOHF | | | Polyline | Model |
| Ex. Overhead Cable TV | EOHCTV | | | Polyline | Model |

L. Record Drawings

The digital Record Drawing submittal should be modified to show “as-built” information. Please include a red line as-built in addition to the digital Record Drawing.

APPENDIX C- Construction Testing Methods

A. Contractor/Developer's Responsibility for Testing & Disinfection

It is the sole responsibility of Contractor/Developer to construct a water main capable of passing the hydrostatic and bacteriological tests. The fact that Citizens Energy Group provides inspection during the construction, sample collection and laboratory testing does not relieve Contractor/Developer's responsibilities in these regards.

It's the responsibility of Contractor/Developer to prevent the consumption of water from a main that has not been disinfected for any and all purposes by their workmen, subcontractors or any other person who may encounter it.

B. Disinfection of Water Mains

The Developer/Contractor will disinfect installed water mains based on the ANSI/AWWA C651 Disinfecting Water Mains and the requirements in this section.

C. Preventive and Corrective Measures During Construction

1. Keeping Pipe Clean and Dry

Precautions shall be taken to protect the interiors of pipes, fittings, and valves against contamination. Pipes delivered for construction shall be stored/strung to minimize the entrance of foreign material. All openings in the pipeline shall be closed with watertight plugs when pipe laying is stopped including at the end of each day, rest breaks or meal periods.

2. Joints

Joints of all pipes in the trench shall be completed before work is stopped. If water accumulates in the trench, the plugs shall remain in place until the trench is dry.

3. Lubricating and Sealing Materials

The lubricant used to seal gaskets shall be NSF 61 certified and suitable for use in potable water. It shall be kept in closed containers and free of foreign debris. Excessive amounts of lubricant may impact bacteriological testing and delay the approval of water mains for use.

4. Cleaning and Swabbing

The interior surface of the pipe shall be swabbed with a five (5) percent hypochlorite disinfection solution. If, in the opinion of the Utility, any dirt remains in the pipe that will not be removed by the flushing operation, then the interior of the pipe shall be cleaned by mechanical means as determined by the Utility in conjunction with the application of a five (5) percent hypochlorite disinfection solution to the interior pipe surface.

5. Wet Trench Construction

When working in a wet trench, calcium hypochlorite granules or tablets shall be added to each length of pipe before it is installed to reduce the risks of bacterial contamination.

6. **Flooding During Construction**
If the main is flooded during construction, the water shall be cleared before construction resumes. The Utility shall be informed of the flooding and the procedures used to remove the excess water before starting to disinfect the main.

7. **Backflow Protection**

New water main shall be kept isolated from the distribution system until satisfactory bacteriological testing are complete. Water required for testing, disinfection, and flushing shall be supplied through a temporary connection between the distribution system and the new main. The temporary connection shall include appropriate backflow device(s). During the hydrostatic pressure test, the temporary connection shall be disconnected creating a gap between the existing distribution system and the new main. After completion of this test, it will be reestablished to flush out the disinfectant water prior to final connection of the new main to the distribution system.

D. Sampling Assemblies

1. **Blow-offs**

Where required, temporary blow-off sampling assemblies shall be installed as indicated in Standard Practice Drawings J and K. Discharge from this assembly will be regulated through the control valve on the top of it. The blow-off valve cannot be used to throttle flow. A 1-inch ball valve must be installed on the assembly to facilitate chlorination of the new water main. Failure to assemble the blow-off apparatus correctly and keep it clean may result in contamination and cause delays.

2. **Hydrants**

Where required, temporary hydrant sampling assemblies need to be installed as indicated in Standard Practice Drawing L. Discharge from this assembly will be regulated through the control valve on the top of the assembly. The hydrant valve cannot be used to throttle flow. A 1" ball valve must be installed on the assembly to facilitate chlorination of the new water main. Failure to assemble the hydrant apparatus correctly and keep it clean may result in contamination and cause delays.

3. **Bleed (Discharge)**

If the new main is not isolated from the existing distribution system, at least one blow-off or hydrant will be turned opened to establish a bleed until satisfactory bacteriological test results are obtained. Sufficient hose should be attached to the end of this assembly to ensure that the area around the assembly is not flooded. During flushing and when the sterilization process is completed, de-chlorination may be necessary. Any bleed with detectable chlorine must be dechlorinated before reaching storm drains or drainage ditches that connect to ponds, lakes, or streams.

E. Hydrostatic Testing

1. All water mains shall be hydrostatically tested in accordance with applicable ANSI/AWWA Standards for the pipe material installed and the requirements in this section. The tests will be conducted in the presence of the Utility or their designated inspector who will verify the results. The hydrostatic testing for DI and PVC pipe shall be governed by the current ANSI/AWWA Standard C600 and C605, respectively.
2. The hydrostatic test shall maintain a pressure of 150 psi for an uninterrupted continuous period of two (2) hours. Test pressure shall not vary by more than ± 5 psi for the duration of the test.

NOTE: The testing methods described in this section are specific for water pressure testing. These procedures do not apply to air pressure testing because of the serious safety hazards involved.

3. Test pressure shall not exceed pipe or thrust-restraint design pressures.
4. All new installations will be disconnected from the main distribution system until hydrostatic testing has been successfully completed.
5. When hydrants are in the test section, the test shall be made against the operating valve in the hydrant. All hydrant branch valves shall be in the open position during this test phase.
6. Acceptance of installation - Acceptance shall be determined based on allowable leakage. If any test of laid pipe discloses leakage greater than the specified amount, repairs or replacements shall be accomplished in accordance with these Standards. Testing shall continue until pipe is accepted.
7. All visible leaks are to be repaired regardless of the amount of leakage.
8. Ductile Iron Pipe Requirement

- a. Valves

Valves shall not be operated in either direction at a differential pressure exceeding the rated valve working pressure. Use of a test pressure greater than the rated valve pressure can result in trapped test pressure between the gates of a double-disc gate valve. For tests at these pressures, the setup should include a provision, independent of the valve, to reduce the line pressure to the rated valve pressure on completion of the test. The valve can then be opened enough to equalize the trapped pressure with the line pressure, or fully opened if desired.

The test pressure shall not exceed the rated pressure of the valves when the pressure boundary of the test section includes closed, resilient-seated gate valves or butterfly valves.

- b. Pressurization

After the pipe has been installed, all newly installed pipe shall be subjected to a hydrostatic pressure of 150 PSI at lowest point of the line. Each section of pipe

shall be slowly filled with water, and the specified test pressure (based on the elevation of the lowest point of the line or section under test and corrected to the elevation of the test gauge) shall be applied by a pump connected to the pipe. Valves shall not be operated in either the opening or closing direction at differential pressures above the rated pressure. It is good practice to allow the system to stabilize at the test pressure before conducting the leakage test.

c. Air Removal

Before applying the specified test pressure, air shall be expelled completely from the section of piping. If permanent air vents are not located at all high points, corporation cocks shall be installed at these points to expel air as the line is filled with water. After all the air has been expelled, the corporation cocks shall be closed, and the test pressure applied. At the conclusion of the pressure test, the corporation cocks shall be removed and plugged or left in place as required by the specifications.

d. Examination

All exposed pipe, fittings, valves, hydrants, and joints shall be examined carefully during the test. Any damaged or defective pipe, fittings, valves, hydrants, or joints that are discovered following the pressure test shall be repaired or replaced with sound material, and the test shall be repeated until satisfactory results are obtained.

e. Leakage Defined

Leakage shall be defined as the quantity of water that must be supplied into the newly laid pipe or any isolated section thereof to maintain pressure within 5 psi of the specified test pressure after the pipe has been filled with water and air has been expelled. Leakage shall not be measured by pressure loss in the test section over a period of time.

f. Allowable Leakage

No pipe installation will be accepted if the leakage is greater than that determined by the following formula from ANSI/AWWA C600-17 Installation of Ductile-Iron Mains and Their Appurtenances (ANSI/AWWA C600-17):

In inch-pound units,
$$L = \frac{SD\sqrt{P}}{148,000}$$

Where:

L = allowable leakage, in gallons per hour

S = length of pipe tested, in feet

D = nominal diameter of pipe, in inches

P = average test pressure during the leakage test, in pounds per square inch (gauge)

Allowable leakage at various pressures is shown in Table 5A from ANSI/AWWA C600-17 (copied by permission. Copyright © 2017, American Water Works Association).

Table 5A Hydrostatic testing allowance per 1,000 ft of pipeline*—gph[†]

| Average Test Pressure, <i>psi</i> | Nominal Pipe Diameter, <i>in.</i> | | | | | | | | | | | | | | | | | |
|-----------------------------------|-----------------------------------|------|------|------|------|------|------|------|------|------|------|------|------|------|------|------|------|------|
| | 3 | 4 | 6 | 8 | 10 | 12 | 14 | 16 | 18 | 20 | 24 | 30 | 36 | 42 | 48 | 54 | 60 | 64 |
| 450 | 0.43 | 0.57 | 0.86 | 1.15 | 1.43 | 1.72 | 2.01 | 2.29 | 2.58 | 2.87 | 3.44 | 4.30 | 5.16 | 6.02 | 6.88 | 7.74 | 8.60 | 9.17 |
| 400 | 0.41 | 0.54 | 0.81 | 1.08 | 1.35 | 1.62 | 1.89 | 2.16 | 2.43 | 2.70 | 3.24 | 4.05 | 4.86 | 5.68 | 6.49 | 7.30 | 8.11 | 8.65 |
| 350 | 0.38 | 0.51 | 0.76 | 1.01 | 1.26 | 1.52 | 1.77 | 2.02 | 2.28 | 2.53 | 3.03 | 3.79 | 4.55 | 5.31 | 6.07 | 6.83 | 7.58 | 8.09 |
| 300 | 0.35 | 0.47 | 0.70 | 0.94 | 1.17 | 1.40 | 1.64 | 1.87 | 2.11 | 2.34 | 2.81 | 3.51 | 4.21 | 4.92 | 5.62 | 6.32 | 7.02 | 7.49 |
| 275 | 0.34 | 0.45 | 0.67 | 0.90 | 1.12 | 1.34 | 1.57 | 1.79 | 2.02 | 2.24 | 2.69 | 3.36 | 4.03 | 4.71 | 5.38 | 6.05 | 6.72 | 7.17 |
| 250 | 0.32 | 0.43 | 0.64 | 0.85 | 1.07 | 1.28 | 1.50 | 1.71 | 1.92 | 2.14 | 2.56 | 3.21 | 3.85 | 4.49 | 5.13 | 5.77 | 6.41 | 6.84 |
| 225 | 0.30 | 0.41 | 0.61 | 0.81 | 1.01 | 1.22 | 1.42 | 1.62 | 1.82 | 2.03 | 2.43 | 3.04 | 3.65 | 4.26 | 4.86 | 5.47 | 6.08 | 6.49 |
| 200 | 0.29 | 0.38 | 0.57 | 0.76 | 0.96 | 1.15 | 1.34 | 1.53 | 1.72 | 1.91 | 2.29 | 2.87 | 3.44 | 4.01 | 4.59 | 5.16 | 5.73 | 6.12 |
| 175 | 0.27 | 0.36 | 0.54 | 0.72 | 0.89 | 1.07 | 1.25 | 1.43 | 1.61 | 1.79 | 2.15 | 2.68 | 3.22 | 3.75 | 4.29 | 4.83 | 5.36 | 5.72 |
| 150 | 0.25 | 0.33 | 0.50 | 0.66 | 0.83 | 0.99 | 1.16 | 1.32 | 1.49 | 1.66 | 1.99 | 2.48 | 2.98 | 3.48 | 3.97 | 4.47 | 4.97 | 5.30 |
| 125 | 0.23 | 0.30 | 0.45 | 0.60 | 0.76 | 0.91 | 1.06 | 1.21 | 1.36 | 1.51 | 1.81 | 2.27 | 2.72 | 3.17 | 3.63 | 4.08 | 4.53 | 4.83 |
| 100 | 0.20 | 0.27 | 0.41 | 0.54 | 0.68 | 0.81 | 0.95 | 1.08 | 1.22 | 1.35 | 1.62 | 2.03 | 2.43 | 2.84 | 3.24 | 3.65 | 4.05 | 4.32 |

* If the pipeline under test contains sections of various diameters, the testing allowance will be the sum of the testing allowance for each size.
[†] Calculated on the basis of Eq 1.

9. PVC Pipe

In PVC pipe, a gross leak can usually be traced to a major problem (i.e., missing gasket, dislodged gasket, broken pipe, loose mechanical joint bolts, inadequate thrust block). Usually these problems are readily detected and quickly repaired.

A minor leak greater than allowable limits can be frustrating and difficult to find and repair. If dye is needed to find a leak, Developer/Contractor shall obtain approval from the Utility prior to use. The best ways to avoid this type of leak is to do the following during installation:

- a. Vent all high points - use a corporation stop if air release valves are not required.
- b. Double and triple check all mechanical joint bolted connections.
- c. Adequately cure thrust blocks before testing.
- d. Exercise care to clean out gasket groove if gaskets are not factory installed. Often rain and dust leave deposits, which must be removed, from exposed gasket grooves. Ensure that exposed gasket grooves are properly cleaned before inserting gaskets.
- e. Be sure when inserting pipe into a mechanical joint or gasket that the spigot end is squarely cut and beveled properly for that hub.

The main line shall be tested prior to installing services.

The following procedure is recommended to determine if air is entrapped in a pipe:

- a. Pressurize with water to desired test pressure.
- b. Allow pressure to drop to pre-determined level.
- c. Measure make-up water required to establish test pressure.
- d. Repeat steps b. and c.

No pipe installation will be accepted if the leakage is greater than that determined by the following formula from ANSI/AWWA C605-13 Underground Installation of Polyvinyl Chloride (PVC) and Molecularly Oriented Polyvinyl Chloride (PVCO) Pressure Pipe and Fittings (ANSI/AWWA C605-13):

In inch-pound units,
$$Q = \frac{LD\sqrt{P}}{148,000}$$

Where:

- Q = Quantity of makeup water (allowable leakage), in gallons per hour
- L = length of pipe tested, in feet
- D = nominal diameter of pipe, in inches
- P = average test pressure during the leakage test, in pounds per square inch (gauge)

Allowable leakage at various pressures is shown in Table 4a from ANSI/AWWA C605-13 (Copyright © 2013, American Water Works Association).

Copyright © 2013 American Water Works Association. All Rights Reserved.

Table 4a Hydrostatic test makeup water allowances per 1,000 ft (50 joints) of PVC pipe, (US gal/hr)

| Avg. Test Pressure | | Nominal Pipe Diameter, in. (mm) | | | | | | | | | | | | | |
|--------------------|---------|---------------------------------|------|------|------|------|------|------|------|------|------|------|------|------|------|
| psi | (kPa) | 4 | 6 | 8 | 10 | 12 | 14 | 16 | 18 | 20 | 24 | 30 | 36 | 42 | 48 |
| 300 | (2,070) | 0.47 | 0.70 | 0.94 | 1.17 | 1.40 | 1.64 | 1.87 | 2.11 | 2.34 | 2.81 | 3.51 | 4.21 | 4.92 | 5.62 |
| 275 | (1,900) | 0.45 | 0.67 | 0.90 | 1.12 | 1.34 | 1.57 | 1.79 | 2.02 | 2.24 | 2.69 | 3.36 | 4.03 | 4.71 | 5.38 |
| 250 | (1,720) | 0.43 | 0.64 | 0.85 | 1.07 | 1.28 | 1.50 | 1.71 | 1.92 | 2.14 | 2.56 | 3.21 | 3.85 | 4.49 | 5.13 |
| 225 | (1,550) | 0.41 | 0.61 | 0.81 | 1.01 | 1.22 | 1.42 | 1.62 | 1.82 | 2.03 | 2.43 | 3.04 | 3.65 | 4.26 | 4.86 |
| 200 | (1,380) | 0.38 | 0.57 | 0.76 | 0.96 | 1.15 | 1.34 | 1.53 | 1.72 | 1.91 | 2.29 | 2.87 | 3.44 | 4.01 | 4.59 |
| 175 | (1,210) | 0.36 | 0.54 | 0.72 | 0.89 | 1.07 | 1.25 | 1.43 | 1.61 | 1.79 | 2.15 | 2.68 | 3.22 | 3.75 | 4.29 |
| 150 | (1,030) | 0.33 | 0.50 | 0.66 | 0.83 | 0.99 | 1.16 | 1.32 | 1.49 | 1.66 | 1.99 | 2.48 | 2.98 | 3.48 | 3.97 |
| 125 | (860) | 0.30 | 0.45 | 0.60 | 0.76 | 0.91 | 1.06 | 1.21 | 1.36 | 1.51 | 1.81 | 2.27 | 2.72 | 3.17 | 3.63 |
| 100 | (690) | 0.27 | 0.41 | 0.54 | 0.68 | 0.81 | 0.95 | 1.08 | 1.22 | 1.35 | 1.62 | 2.03 | 2.43 | 2.84 | 3.24 |
| 75 | (520) | 0.23 | 0.35 | 0.47 | 0.59 | 0.70 | 0.82 | 0.94 | 1.05 | 1.17 | 1.40 | 1.76 | 2.11 | 2.46 | 2.81 |
| 50 | (340) | 0.19 | 0.29 | 0.38 | 0.48 | 0.57 | 0.67 | 0.76 | 0.86 | 0.96 | 1.15 | 1.43 | 1.72 | 2.01 | 2.29 |

Note: The above equation for a gasket joint pipe in 20-foot lengths results in a leakage of 10.5 gallons per inch diameter per mile per day when evaluated at a pressure of 150 psi.

10. Polyethylene Pipe (PE)

Suitable precautions should be taken to eliminate hazards to personnel in the proximity of lines being tested in the event of piping system rupture.

After the pipeline has been laid, it should be adequately anchored by placing initial backfill up to at least six (6) inches over the pipe. The joints and fittings, and particularly flanged connections may be left uncovered for visual leak inspection. The pipeline should be slowly filled with water, taking care to bleed off all trapped air. It should then be hydrostatically tested with a pressure of 150 psi at the lowest elevation in the system.

An alternate test procedure consists of two steps: An initial expansion phase and the test phase. When PE pipe is first pressurized, an initial gradual diametric expansion occurs which results in a drop-in test pressure that must be compensated by the addition of make-up water. In the first phase of this test procedure, sufficient make-up water is added four times to the system at approximately one-hour intervals to return to the test procedure.

At the completion of this first phase, approximately four hours after initially pressurizing the pipe under test, the actual test phase then commences. The test phase should not exceed three hours. At the end of the test phase, a measured amount of make-up water is added to return to the test pressure. Alternatively, testing for leakage can be done by maintaining the test pressure (described above)

over a period of four hours, and then dropping the pressure by 10 psi. If the pressure remains steady (i.e., within five percent of the target value) for an hour, this indicates that there is no leakage in the system.

Note: Under no circumstances shall the total time under test exceed eight (8) hours. If the test is not completed due to leakage, equipment failure, etc., the test section shall be permitted to “relax” for eight (8) hours prior to the next testing sequence.

Table E-4 - Allowance for Expansion Under Pressure¹ for Ambient Conditions

| Nominal Pipe Size | | Allowance for Expansion (U.S. Gal (L) per 100 ft (30.48 m) of Pipe) | | | | | |
|----------------------|---------|--|-----------|-------------|-----------|-------------|-----------|
| | | 1-Hour Test | | 2-Hour Test | | 3-Hour Test | |
| in. | (mm) | gal | (L) | gal | (L) | gal (L) | (L) |
| 4 | (100) | 0.13 | (0.49) | 0.25 | (0.95) | 0.40 | (1.51) |
| 6 | (150) | 0.30 | (1.14) | 0.60 | (2.27) | 0.90 | (3.41) |
| 8 | (200) | 0.50 | (1.89) | 1.00 | (3.78) | 1.50 | (5.68) |
| 10 | (250) | 0.75 | (2.84) | 1.30 | (4.92) | 2.10 | (7.95) |
| 12 | (300) | 1.10 | (4.16) | 2.30 | (8.71) | 3.40 | (12.87) |
| 14 | (350) | 1.40 | (5.30) | 2.80 | (10.60) | 4.20 | (15.90) |
| 16 | (400) | 1.70 | (6.44) | 3.30 | (12.49) | 5.00 | (18.93) |
| 18 | (450) | 2.20 | (8.33) | 4.30 | (16.28) | 6.50 | (24.61) |
| 20 | (500) | 2.80 | (10.60) | 5.50 | (20.82) | 8.00 | (30.28) |
| 22 | (550) | 3.50 | (13.25) | 7.00 | (26.50) | 10.50 | (39.75) |
| 24 | (600) | 4.50 | (17.03) | 8.90 | (33.69) | 13.30 | (50.35) |
| 28 | (650) | 5.50 | (20.82) | 11.10 | (42.02) | 16.80 | (63.59) |
| 32 | (800) | 7.00 | (26.50) | 14.30 | (54.13) | 21.50 | (81.39) |
| 36 | (900) | 9.00 | (34.07) | 18.00 | (68.14) | 27.00 | (102.21) |
| 42 | (1050) | 12.00 | (45.42) | 22.50 | (85.17) | 35.00 | (132.49) |
| 48 | (1200) | 15.00 | (56.78) | 27.00 | (102.21) | 43.00 | (162.77) |
| 54 | (1350) | 18.00 | (68.14) | 30.00 | (113.56) | 50.00 | (189.27) |
| 63 | (1575) | 27.00 | (102.21) | 54.00 | (204.41) | 81.00 | (306.61) |

¹These allowances only apply to the test phase and not the initial expansion phase. In addition, they assume that the pipe is being tested for a system design pressure equal to the pipe's pressure class. If the pipe is being tested to a lower system design pressure, the above allowances should be reduced by the ratio of the system design pressure to the pipe's pressure class.

F. Flushing

All water utilized for testing and flushing is to be at the Contractor/Developer's expense. The new mains shall be flushed prior to chlorination. The flushing velocity to be obtained for pipes 12 inches and smaller in diameter shall not be less than 2.5 ft/sec. The Contractor/Developer shall make necessary arrangements to attain the minimum velocity. The Contractor/Developer shall take due precaution in providing for adequate drainage from the site. The minimum volume of water to be flushed, at required velocity, shall be not less than the 1.5 times the volume of the pipeline from the point of filling to the point of blow-off. The Contractor/Developer should verify that proposed hydrants to be used have adequate pressure. A metered bleed shall be set up and allowed to flow at a minimum of 50 gallons per minute for a minimum of 16 hours prior to bacteriological sampling at each dead-end location.

Flushing is no substitute for preventive measures.

It is the responsibility of the Contractor/Developer to remove the flushing water or the chlorinated water from the project area. The Contractor/Developer is responsible for any damage as a result of flushing operations.

Table E-5 Flow Required (GPM) for Given Velocity

| Pipe Size (in.) | Pipe Area (sq. ft.) | 1 ft/sec | 2.5 ft/sec | 5 ft/sec | 10 ft/sec |
|-----------------|---------------------|----------|------------|----------|-----------|
| 2 | 0.02 | 10 | 25 | 50 | - |
| 4 | 0.09 | 40 | 100 | 200 | 390 |
| 6 | 0.20 | 90 | 200 | 440 | 880 |
| 8 | 0.35 | 155 | 400 | 780 | 1560 |
| 10 | 0.55 | 245 | 600 | 1220 | 2240 |
| 12 | 0.79 | 350 | 900 | 1760 | 3520 |
| 14 | 1.07 | 480 | 1200 | 2400 | - |
| 16 | 1.40 | 625 | 1600 | 3140 | - |

G. Bacteriological Tests

1. Standard conditions:
After final flushing and before the new water main is connected to the distribution system, two consecutive sets of acceptable samples, taken at least 24 hr. apart, shall be collected from the new main. (NOTE: The pipe, the water loaded into the pipe, and any debris exert a chlorine demand that can interfere with disinfection.) At least one set of samples shall be collected from the end of the line and at least one set from each branch. Samples shall be tested for bacteriological and chemical quality in accordance with *Standard Methods for the Examination of Water and Wastewater*. Bacteriological sample results must indicate the absence of coliform organisms and the chemical sample results must indicate the presence of chlorine residual, a low turbidity, and no unusual odors.
2. Special conditions:
If trench water has entered the new main during construction or if, in the opinion of the purchaser, excessive quantities of dirt or debris have entered the new main, the main must be disinfected with a high chlorine residual and held for a 16-hour minimum. The main must be dechlorinated appropriately prior to bacteriological sampling.
3. Sampling procedure:
Samples for bacteriological analysis shall be collected in sterile bottles treated with sodium thiosulfate, as required by *Standard Methods for the Examination of Water and Wastewater*. No hoses or fire hydrant shall be used in the collection of samples unless otherwise approved by the Utility. For pipe repairs, if no other sampling ports are available, cleaned and well-flushed fire hydrants may be used with the understanding that they do not represent optimum sampling conditions. A suggested combination blowoff and sampling tap used for mains up to and including 8-in. diameter is shown in ANSI/AWWA C651 Figure 2. There should be no water in the trench up to or around the connection for sampling. Citizens personnel will collect bacteria and chemistry samples from the sample port and deliver them to the laboratory for analysis. Chlorine residual shall be tested in the field at the time of sample collection.
4. Sample results:
If testing results indicate a total coliform positive result or an odor consistent with pipe lubricant, the sample has failed and additional samples will be required. Citizens personnel will collect a second set of samples (typically the next day) and deliver them to the laboratory. If samples fail bacteria tests again, corrective measures must be taken before any additional sampling.
5. Record of compliance:
The record of compliance shall be the bacteriological test results certifying that the water sampled from the new water main is free of coliform bacteria contamination.
6. Connection with Existing Distribution System:
If final connection has not been completed and all documents are not received within 60 days, the main shall be retested as described herein before final connection will be authorized by the Utility.

| Standard Practice Drawings | | |
|----------------------------|--|------------------|
| Drawing | Title | Status |
| A | Water and Sewer Main Separation Detail | Active |
| A.1 | Water Main and Service Backfill Requirements | Active |
| A.2 | Thrust Blocking | Active |
| B | Standard Hydrant Setting | Active |
| C | Standard Hydrant Setting for 6" and 8" Water Main Sizes | Archived in 2020 |
| D | Cul-De-Sac Water Main and Hydrant Installation | Active |
| E | Cul-De-Sac Water Main and Hydrant at Intersection | Active |
| F | Typical Valve Placement | Active |
| G | Standard 8" Valve Box and Cover | Active |
| H | Typical Channel Crossing | Active |
| H.1 | Not Used | Active |
| H.2 | Water Main Lowering | Active |
| I | Typical Boring Casing Pipe | Active |
| J | 2" Blow-off Assembly for 3" Through 8" Main | Active |
| K | 2" Blow-off Assembly for 12", 16", 20" and 24" Main | Active |
| L | Standard Hydrant/Blowoff Bleed | Active |
| L.1 | Standard Hydrant to Blowoff Bleed | Active |
| L.2 | Blowoff Feed to Blowoff Bleed | Active |
| L.3 | Standard Flushing | Active |
| L.4 | Universal Hydrant Meter Setup | Active |
| M | Air relief Apparatus for Water Mains | Active |
| N | 1-1/2" & 2" Service Line Swing Joint | Active |
| O | Installation of Restraints | Active |
| O.1 | Vehicle Impact Protection for Hydrants | Active |
| P | Sampling Station Standard Arrangement | Active |
| Q | Main Installation Between Properties | Active |
| R | Tracing Station | Active |
| S | Standard Installation for Multiple Meter Settings | Active |
| T | Standard Service Line Installation and Setting for 5/8", 3/4" and 1" Meter in Single Pit | Active |
| T.1 | STANDARD SERVICE LINE INSTALLATION AND SETTING FOR TWO (2) 5/8" METERS IN SINGLE PIT | Archived in 2020 |
| T.2 | ACCEPTABLE DUAL METER PIT LOCATION | Archived in 2020 |
| T.3 | Split Service Line in Common Areas | Active |
| T.4 | Dual Meter Connection With dual RPZ | Active |
| T.5 | Irrigation System Disconnection Detail | Active |
| T.WF1 | Standard 3/4" Water Meter and Pit Details | Active |
| T.WF2 | 3/4" Dual Water Meter and Pit Details (for Residential) | Archived in 2020 |
| T.WF3 | 1" Water Meter and Pit Details | Active |
| T.WF4 | | |
| T.WF5 | Irrigation System Connection Detail (Residential) | Active |
| T.WF6 | Standard Fire Service and Meter Vault | Active |
| T.WF7 | Dual Meter Connection with Dual RPZ | Active |

| | | |
|-------|---|------------------|
| T.WF8 | Duel Meter Connection with Duel RPZ | Archived in 2020 |
| U | Minimum Requirements for Water Stop Installation | Active |
| V | 6'x6'x6' Meter Vault | Archived in 2019 |
| W | 8'-6"x 5'-6"x7' Meter Vault | Archived in 2019 |
| X | 4'x8'x7' Meter Vault | Archived in 2019 |
| Y.1 | 4'x8'x7' Meter Vault for 1 ½" Domestic Meters | Active |
| Y.2 | 4'x8'x7' Meter Vault for 2" Domestic Meters | Active |
| Y.3 | 4'x8'x7' Vault for backflow Prevention with F.D.C. and P.I.V. | Active |
| Y.4 | 4'x8'x7' vault for Backflow Prevention | Active |
| Y.5 | 6'x10'x7' Vault for 3" Domestic Meters | Active |
| Y.6 | 6'x10'x7' Vault for 4" Domestic Meters | Active |
| Y.7 | 6'x10'x7' Vault for Fire Meters | Active |
| Y.8 | 6'x10'x7' Vault for combination Fire and Domestic Services | Active |
| Z | Polyethylene Service Line Meter Support | Active |

CITIZENS WATER
STANDARD PRACTICE

A

REVISION DATE: 09/29/2021

ISSUE DATE: 6/8/2009

WATER MAIN SEPARATION FROM OTHER UTILITIES

NOTE:

WATER MAIN AND SANITARY SEWERS
SHALL BE PLACED IN SEPARATE
TRENCHES.

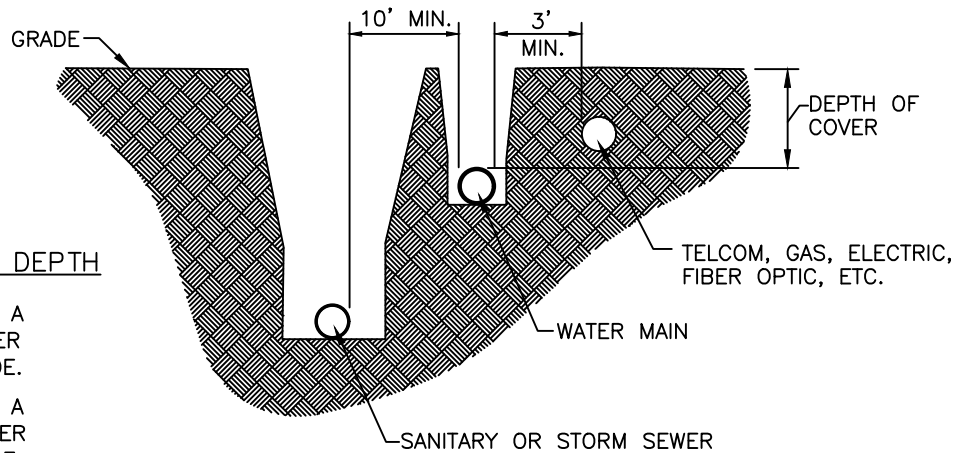

TYPICAL WATER MAIN DEPTH

1. ALL PIPE SHALL HAVE A MINIMUM OF 54" COVER BELOW FINISHED GRADE.
2. ALL PIPE SHALL HAVE A MAXIMUM OF 82" COVER BELOW FINISHED GRADE. DEPTHS GREATER THAN 82" COVER WILL REQUIRE A LOWERING

WATER MAIN LAYING PARALLEL
TO OTHER UTILITIES
SECTION VIEW

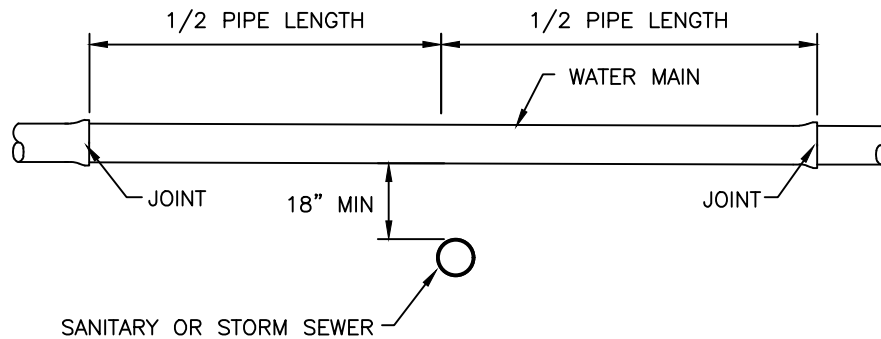

WATER MAIN CROSSING SEWER
SECTION VIEW

CITIZENS WATER
STANDARD PRACTICE

A.1

REVISION DATE: 9/20/2018

ISSUE DATE: 7/17/2013

WATER MAIN AND SERVICE BACKFILL
REQUIREMENTS

SURFACE RESTORATION TO BE COMPLETED
PER LOCAL STANDARDS OR CITIZENS WATER
SPECIFICATIONS, WHICH EVER IS GREATER

WITHIN 5' OF PAVEMENT:
B-BORROW COMPACTED TO 95%
MAXIMUM DENSITY, OR PER LOCAL
SPECIFICATIONS. 5' OR GREATER
FROM PAVEMENT: CLEAN BACKFILL,
PER SPECIFICATIONS

GRANULAR BACKFILL,
SAND OR B-BORROW,
COMPACTED TO 95%
MAXIMUM DENSITY

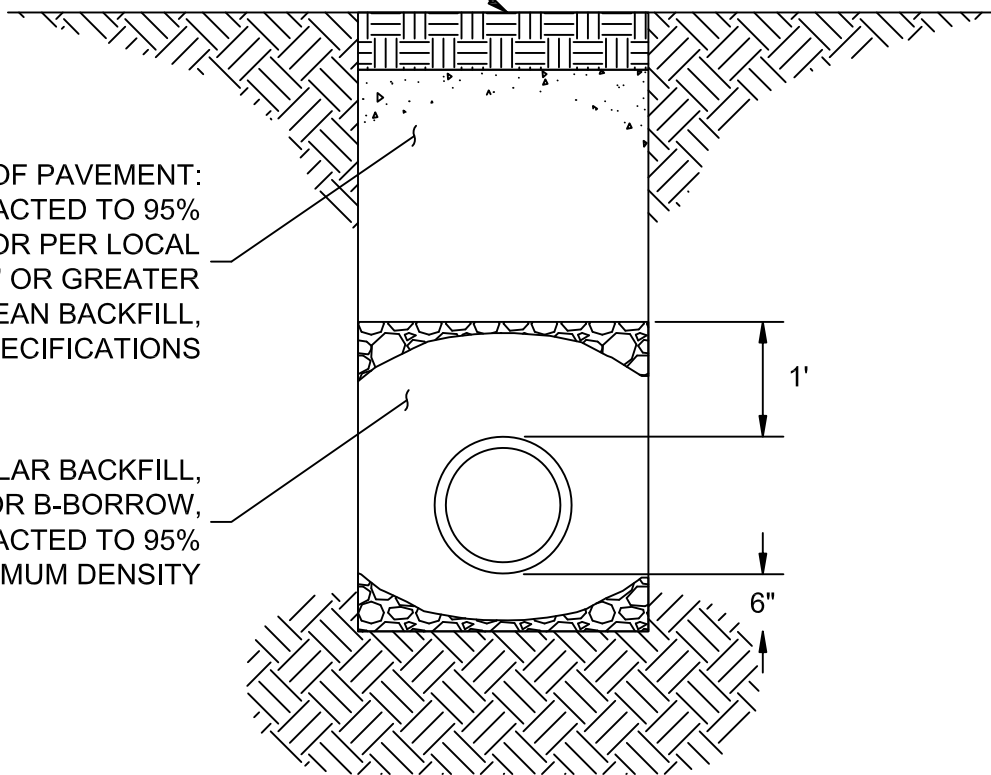

SCALE: NTS

NOTE:
COMPACTED BACKFILL IN LIFTS OF
12" MAXIMUM. TRENCH EXCAVATION
SHALL CONFORM TO LOCAL
STANDARDS.

CITIZENS WATER
STANDARD PRACTICE

A.2

REVISION DATE: 10/02/2019

ISSUE DATE: 12/31/2019

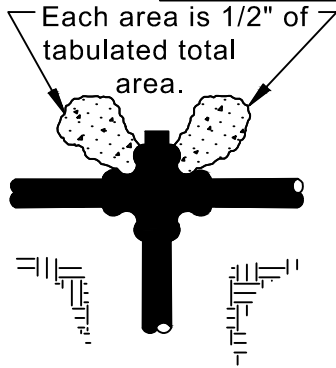

PLUGGED CROSS

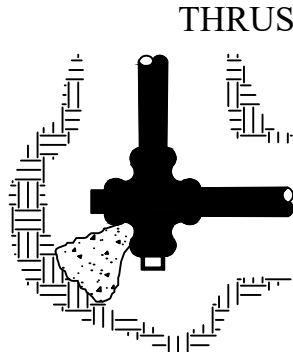

PLUGGED CROSS

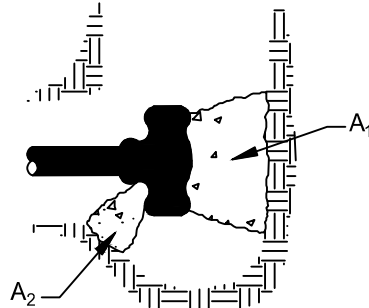

TEE

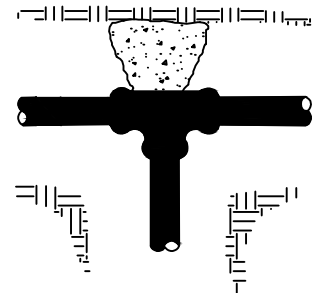

TEE

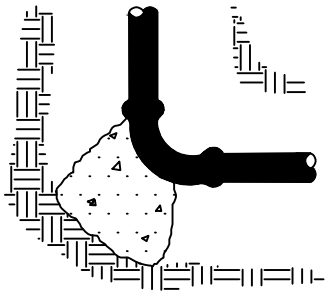

BEND

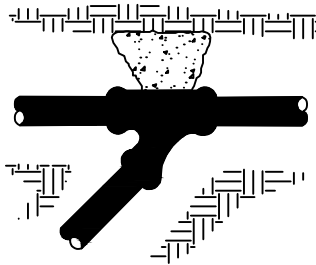

WYE

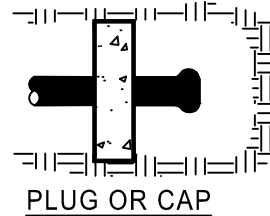

PLUG OR CAP

Notes:

- 1) CONCRETE THRUST BLOCKING TO BE POURED AGAINST UNDISTURBED EARTH.
- 2) KEEP CONCRETE CLEAR OF JOINT AND ACCESSORIES.
- 3) POLYETHYLENE ENCASUREMENT SHALL BE PLACED BETWEEN CONCRETE AND FITTINGS.
- 4) ALL POURED IN PLACE CONCRETE SHALL HAVE A 28 DAY STRENGTH OF 3,000 P.S.I., 2" TO 4" SLUMP AND INCLUDE WIRE MESH FOR REINFORCEMENT.
- 5) MINIMUM SOIL BEARING SURFACE AREA REQUIREMENTS ARE PROVIDED BELOW BASED ON 150 P.S.I. WATER PRESSURE PLUS 100 P.S.I. WATER HAMMER AND SOIL BEARING CAPACITY OF 3,000 POUNDS PER SQUARE FOOT.

| Minimum Soil Bearing Surface Area (ft ²) (Assuming 3,000 psf Soil Bearing Capacity) | | | | |
|--|------------------|-----|-----|----------------------------|
| Pipe Size | Horizontal Bends | | | Tee or Dead End (Plug/Cap) |
| | 22-1/2° | 45° | 90° | |
| 6" | | 6 | 8 | 6 |
| 8" | | 6 | 8 | 6 |
| 12" | 4 | 6 | 11 | 8 |
| 16" | 6 | 11 | 22 | 15 |
| 20" | 9 | 18 | 36 | 24 |
| 24" | 13 | 27 | 50 | 36 |
| 30" | 20 | 45 | 76 | 57 |
| 36" | 31 | 59 | 115 | 80 |

CITIZENS WATER
STANDARD PRACTICE

B

REVISION DATE: 10/02/2019

ISSUE DATE: 12/31/2019

STANDARD HYDRANT SETTING

NOTES:

1. ALL HYDRANTS SHALL BE RESTRAINED TO THE HYDRANT TEE WITH DUCTILE IRON BRANCH PIPING ENCASED IN POLYETHYLENE WRAP.
2. SWIVEL 90° BEND MAY BE USED TO INSTALL HYDRANT AND VALVE IN GRASS STRIP BETWEEN CURB & SIDEWALK.
3. A MANUFACTURED "OUT OF SERVICE" SIGN WILL BE REQUIRED ON HYDRANTS UNTIL MAIN HAS BEEN PLACED "IN SERVICE" BY THE INSPECTOR.
4. FOR BRANCH PIPE LONGER THAN 10', INSTALL TRACING WIRE THROUGH TEST STATION.

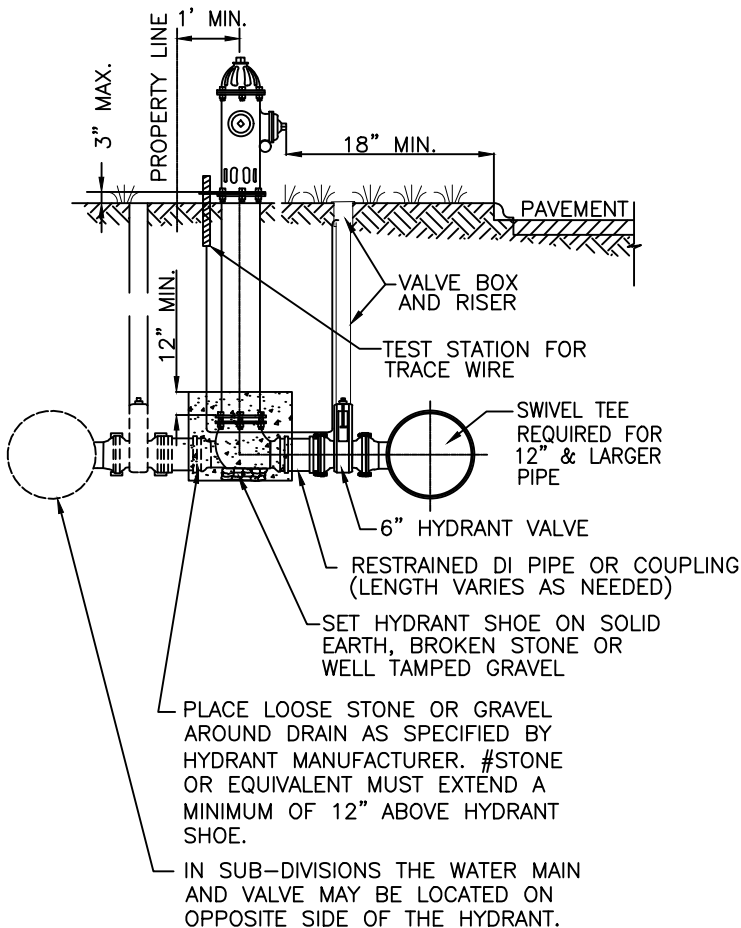

SECTION VIEW
(WITHOUT SIDEWALK)

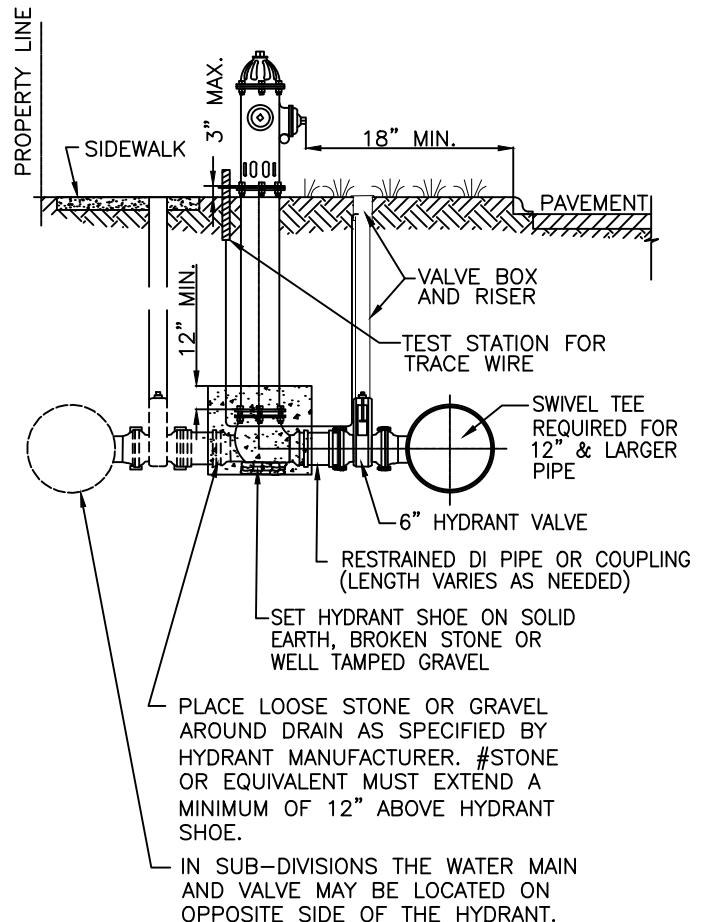

SECTION VIEW
(WITH SIDEWALK)

CITIZENS WATER
STANDARD PRACTICE

D

REVISION DATE: 10/20/2020

ISSUE DATE: 6/8/2009

**CUL-DE-SAC WATER MAIN AND
 HYDRANT INSTALLATION**

NOTES:

1. VALVE REQUIRED AT EACH CUL-DE-SAC. VALVE SHALL BE INSTALLED TO AVOID CURBS & SIDEWALKS.
2. HYDRANT SHALL BE INSTALLED WITHIN 150' OF THE BACK EDGE OF PAVEMENT OF CUL-DE-SAC.
3. WATER MAINS SHALL BE INSTALLED ON OPPOSITE SIDE OF STREET FROM SANITARY SEWER.

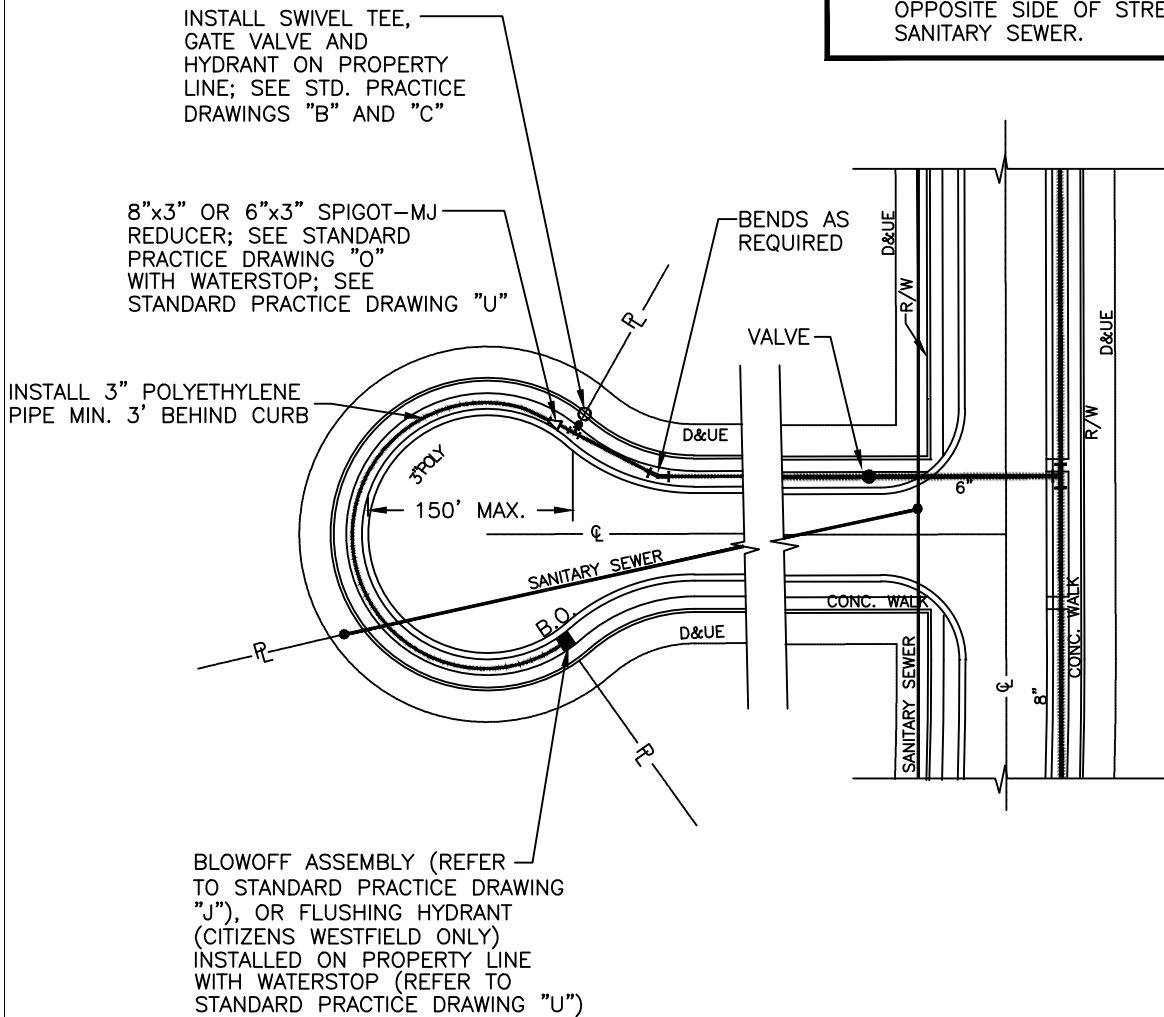

PLAN VIEW

CITIZENS WATER
STANDARD PRACTICE

E

REVISION DATE: 10/20/2020

ISSUE DATE: 6/8/2009

**CUL-DE-SAC WATER MAIN WITH
 HYDRANT AT INTERSECTION**

NOTES:

1. VALVE REQUIRED AT EACH CUL-DE-SAC. VALVE SHALL BE INSTALLED TO AVOID CURBS & SIDEWALKS.
2. HYDRANT SHALL BE INSTALLED WITHIN 150' OF THE BACK EDGE OF PAVEMENT OF CUL-DE-SAC.
3. WATER MAINS SHALL BE INSTALLED ON OPPOSITE SIDE OF STREET FROM SANITARY SEWER.

8"x3" OR 6"x3" SPIGOT-MJ REDUCER; SEE STANDARD PRACTICE DRAWING "O" WITH WATERSTOP; SEE STANDARD PRACTICE DRAWING "U"

INSTALL 3" POLYETHYLENE PIPE MIN. OF 3' BEHIND CURB

BLOWOFF ASSEMBLY (REFER TO STANDARD PRACTICE DRAWING "J"), OR FLUSHING HYDRANT (CITIZENS WESTFIELD ONLY) INSTALLED ON PROPERTY LINE WITH WATERSTOP (REFER TO STANDARD PRACTICE DRAWING "U")

INSTALL SWIVEL TEE, GATE VALVE AND HYDRANT ON PROPERTY LINE; SEE STD. PRACTICE DRAWINGS "B" AND "C"

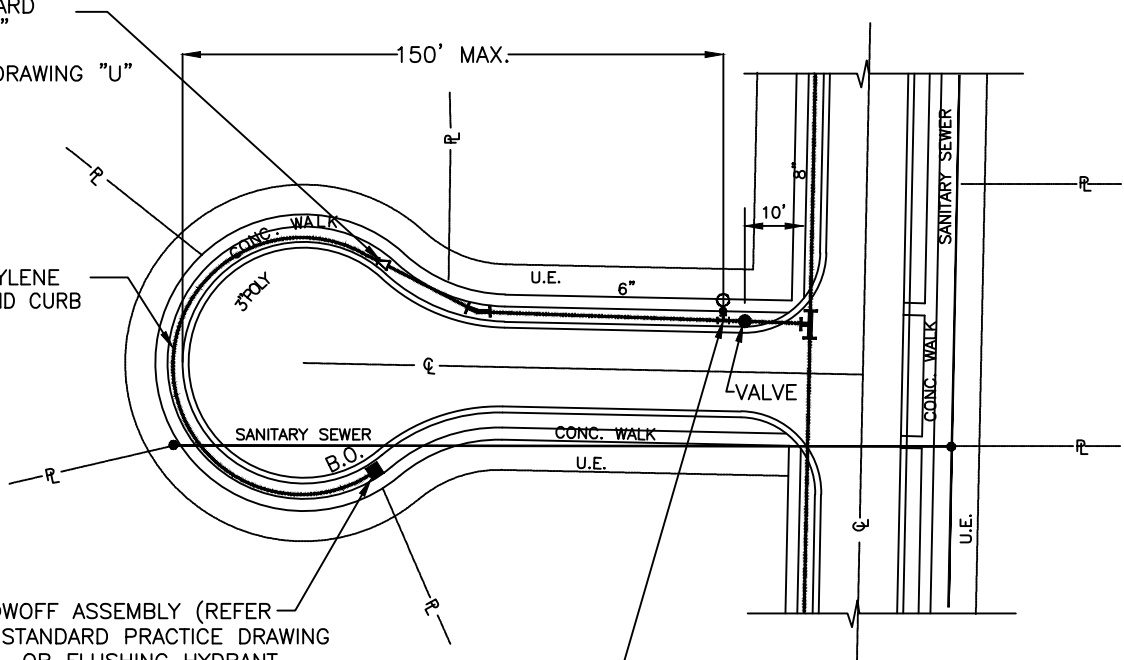

PLAN VIEW

CITIZENS WATER
STANDARD PRACTICE

F

REVISION DATE: 10/20/2020

ISSUE DATE: 6/8/2009

TYPICAL VALVE PLACEMENT

VALVE DESIGN AT INTERSECTION

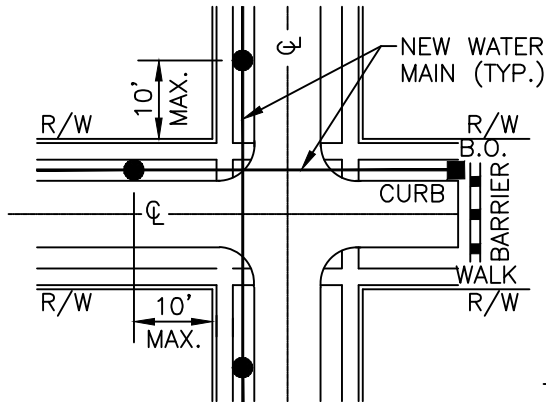

VALVE DESIGN AT TEE INTERSECTION

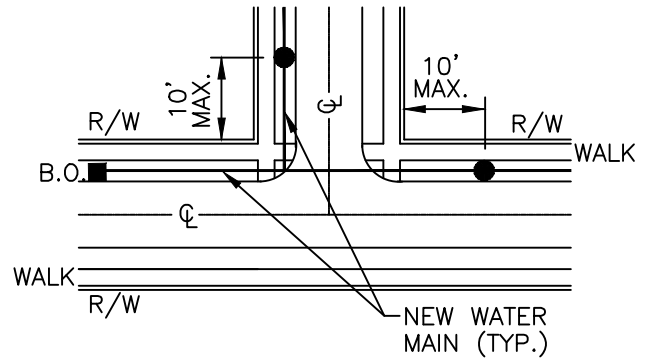

PLAN VIEWS

CONTINUOUS RUNS

VALVE SEPARATION: 6" THROUGH 12" VALVES, INSTALLATION EVERY 1000' TO 1200'
16" THROUGH 24" VALVES, INSTALLATION EVERY 1200' TO 1800'
30" OR LARGER VALVES, MAXIMUM 1800'

FOR LARGER MAINS THE VALVE SEPARATION MAY BE REDUCED WITHIN A DEVELOPMENT,
AS APPROVED BY THE UTILITY.

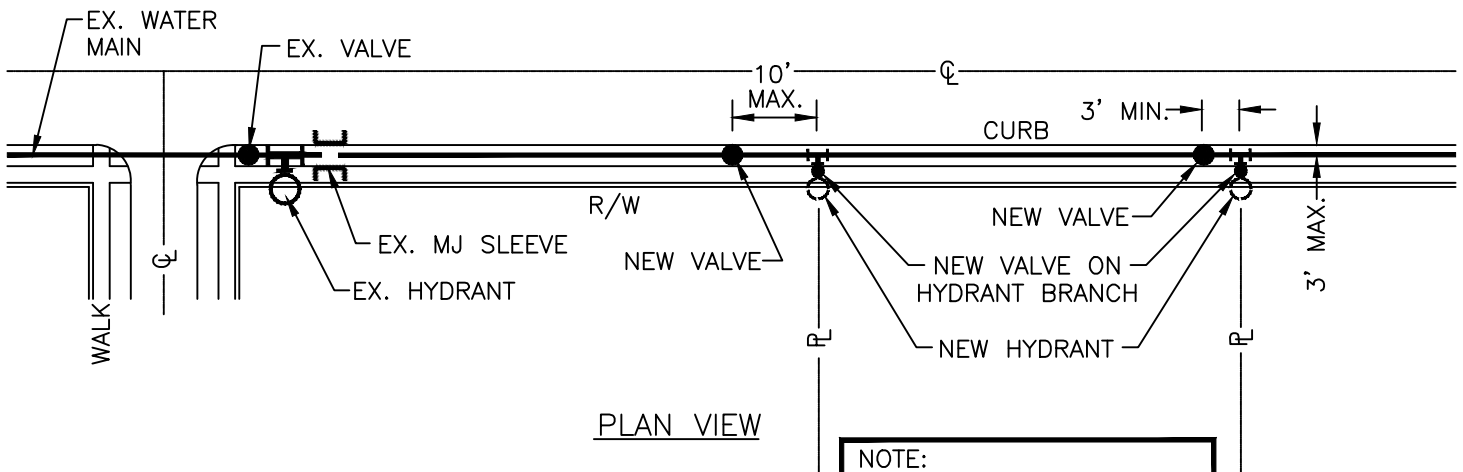

PLAN VIEW

NOTES:
SEE SEC. 2.03-C FOR VALVE
INSTALLATION INFORMATION

SEE SEC. 7.05 FOR VALVE
OPENING INFORMATION

NOTE:
ALL VALVES ARE TO BE
INSTALLED WITHIN 10'
OF AN INTERSECTION
OR NEAR A FIRE HYDRANT.

CITIZENS WATER
STANDARD PRACTICE

G

REVISION DATE: 10/11/2021

ISSUE DATE: 6/8/2009

STANDARD 8" VALVE BOX AND COVER

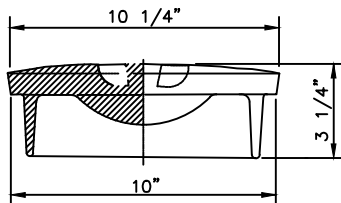
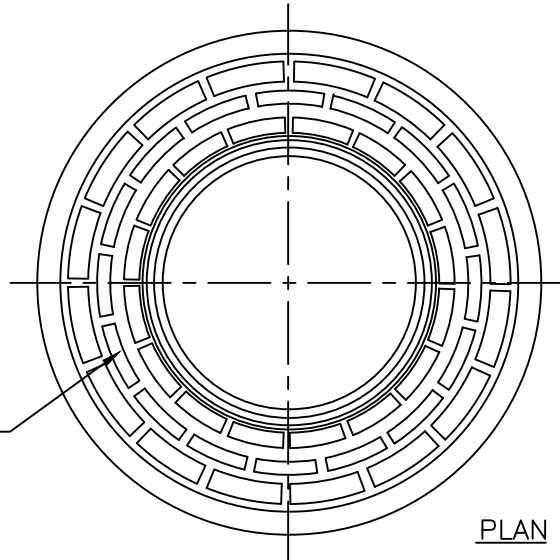
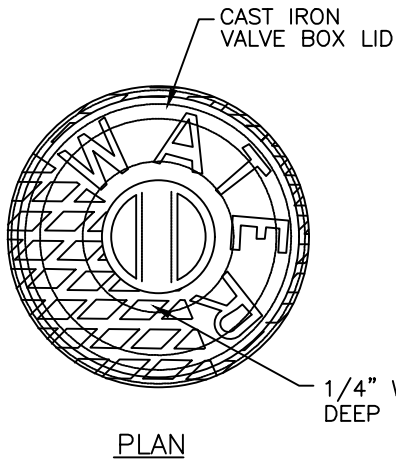

SECTION
VALVE BOX LID

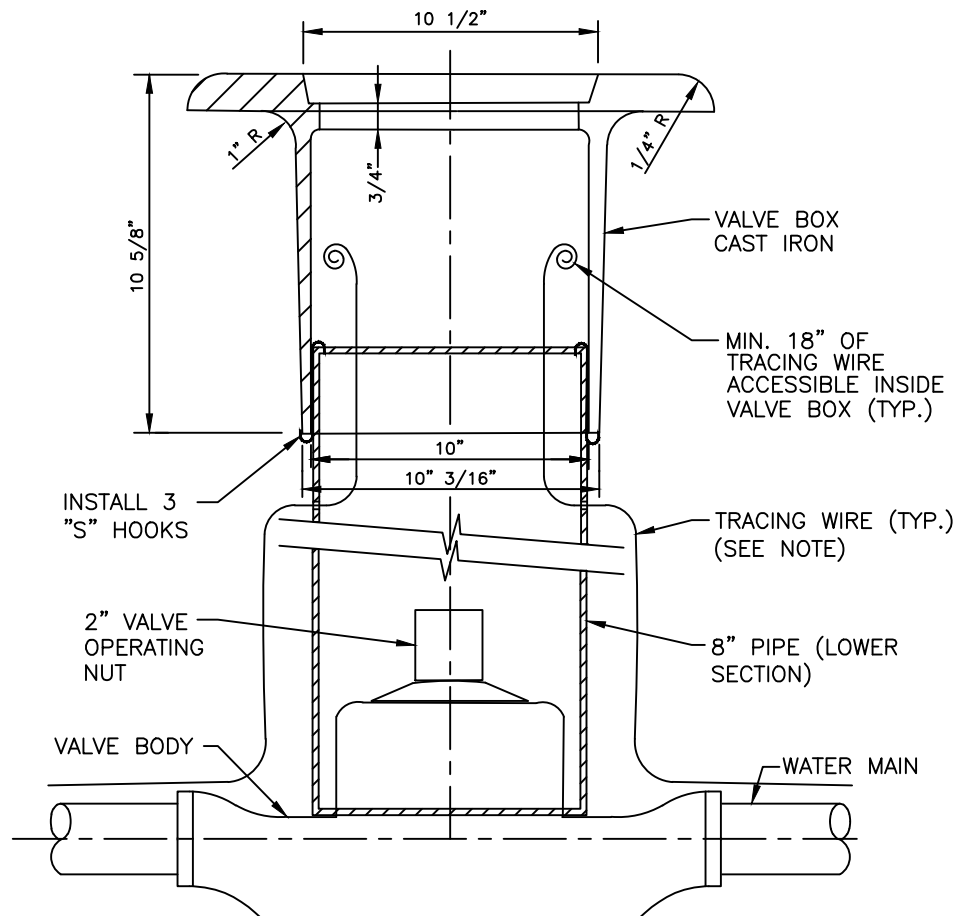

SECTION
VALVE BOX

NOTE:
 TRACING WIRE SHOULD
 RUN ON OUTSIDE OF
 RISER UNTIL IT REACHES A
 POINT 10" BELOW TOP OF
 RISER, THEN ENTER RISER
 THRU DRILLED HOLE.

CITIZENS WATER STANDARD PRACTICE

H

REVISION DATE: 10/20/2020

ISSUE DATE: 3/1/2010

TYPICAL CHANNEL CROSSING

NOTES:

1. ALL PIPE USED IN CHANNEL CROSSING SHALL BE POLYETHYLENE PIPE OR DUCTILE IRON WITH RESTRAINED BENDS. (SEE STANDARD PRACTICE DRAWING "O" FOR RESTRAINED JOINT)
2. EXCAVATION WITHIN STREAM BED TO BE BACKFILLED WITH APPROVED MATERIAL AND COMPACTED.

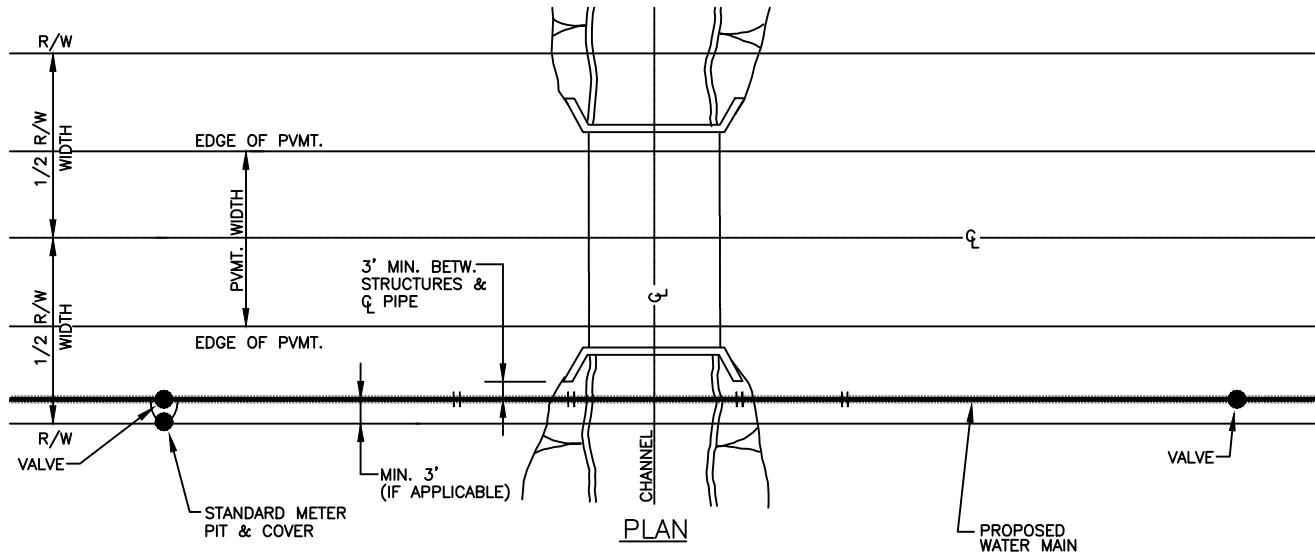
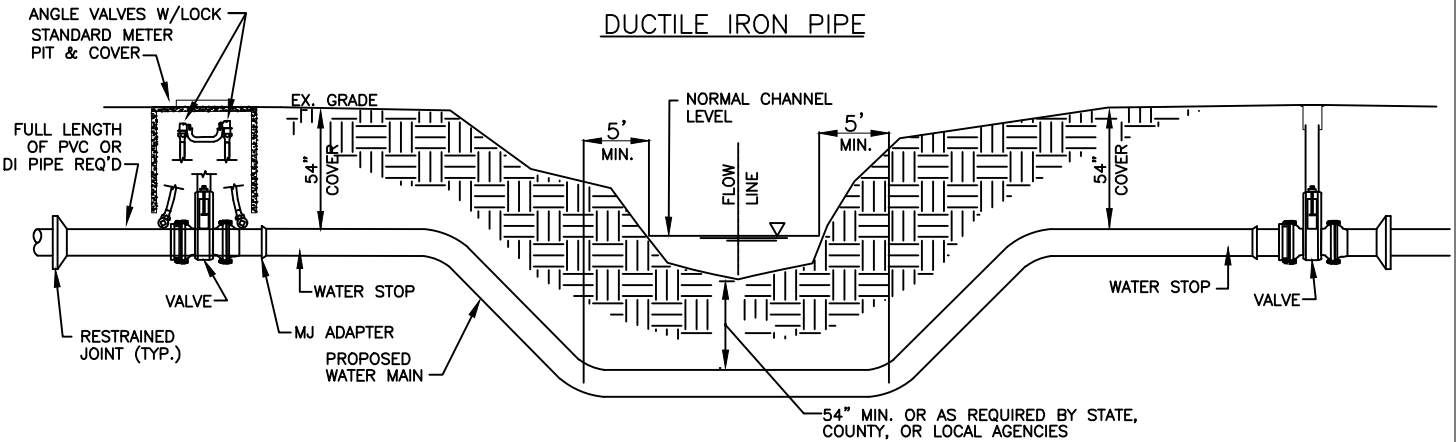
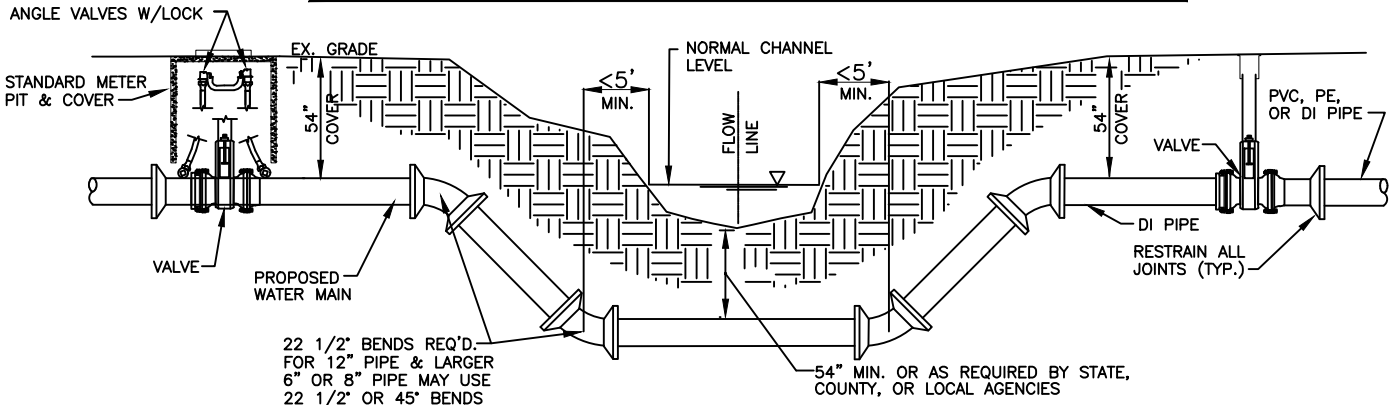

CITIZENS WATER
STANDARD PRACTICE

H.2

REVISION DATE: 10/02/2019

ISSUE DATE: 12/31/2019

WATER MAIN LOWERING

NOTES:

- ALL PIPE USED IN WATER MAIN LOWERING SHALL BE POLYETHYLENE PIPE OR DUCTILE IRON WITH RESTRAINED BENDS. (SEE STANDARD PRACTICE DRAWING "O" FOR RESTRAINED JOINT)

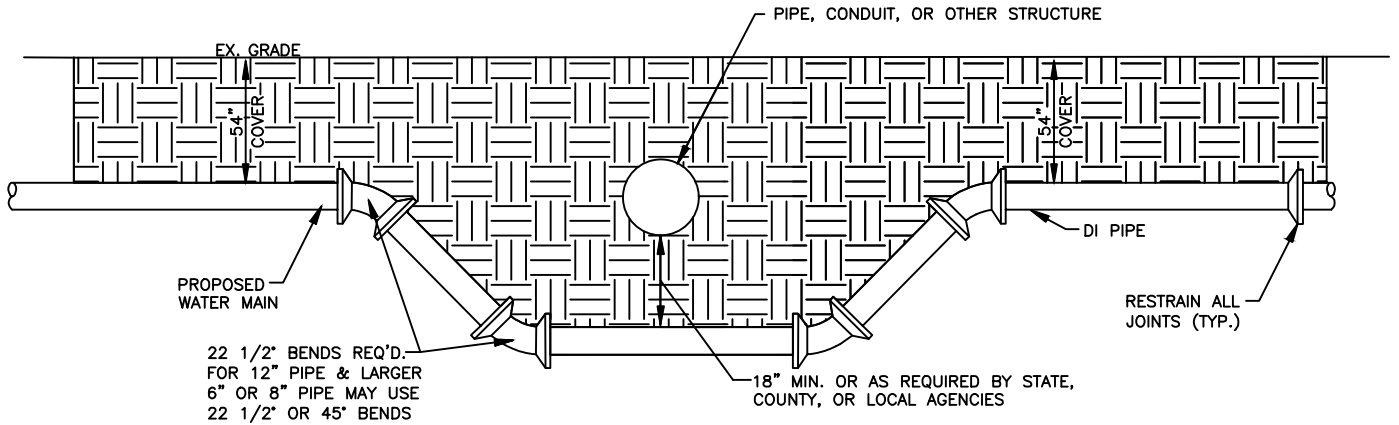

DUCTILE IRON PIPE

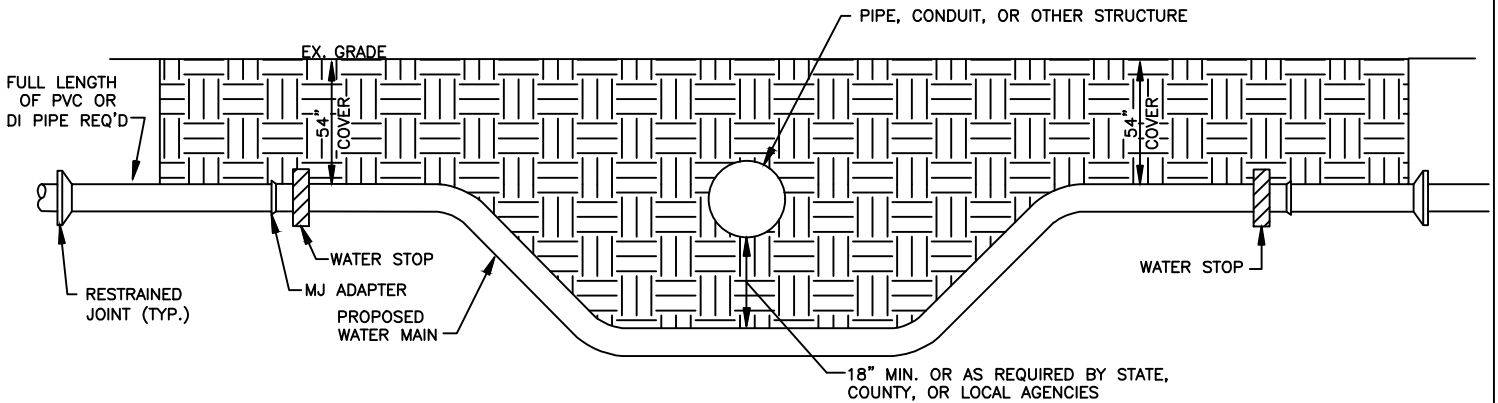

POLYETHYLENE PIPE

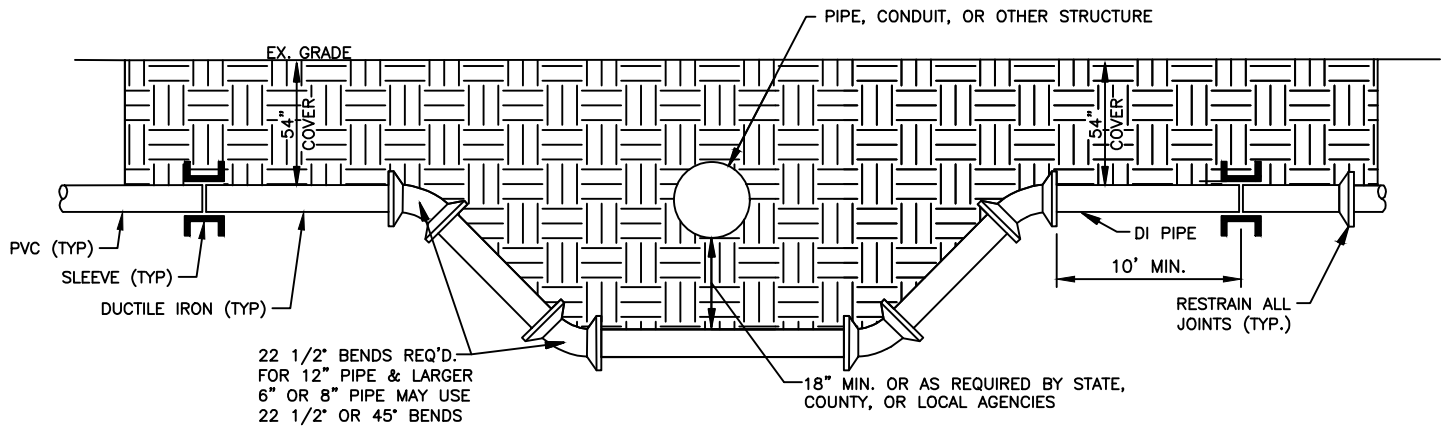

PVC PIPE WITH DUCTILE IRON PIPE

CITIZENS WATER
STANDARD PRACTICE

REVISION DATE: 3/1/2010

ISSUE DATE: 3/1/2010

TYPICAL BORING CASING PIPE

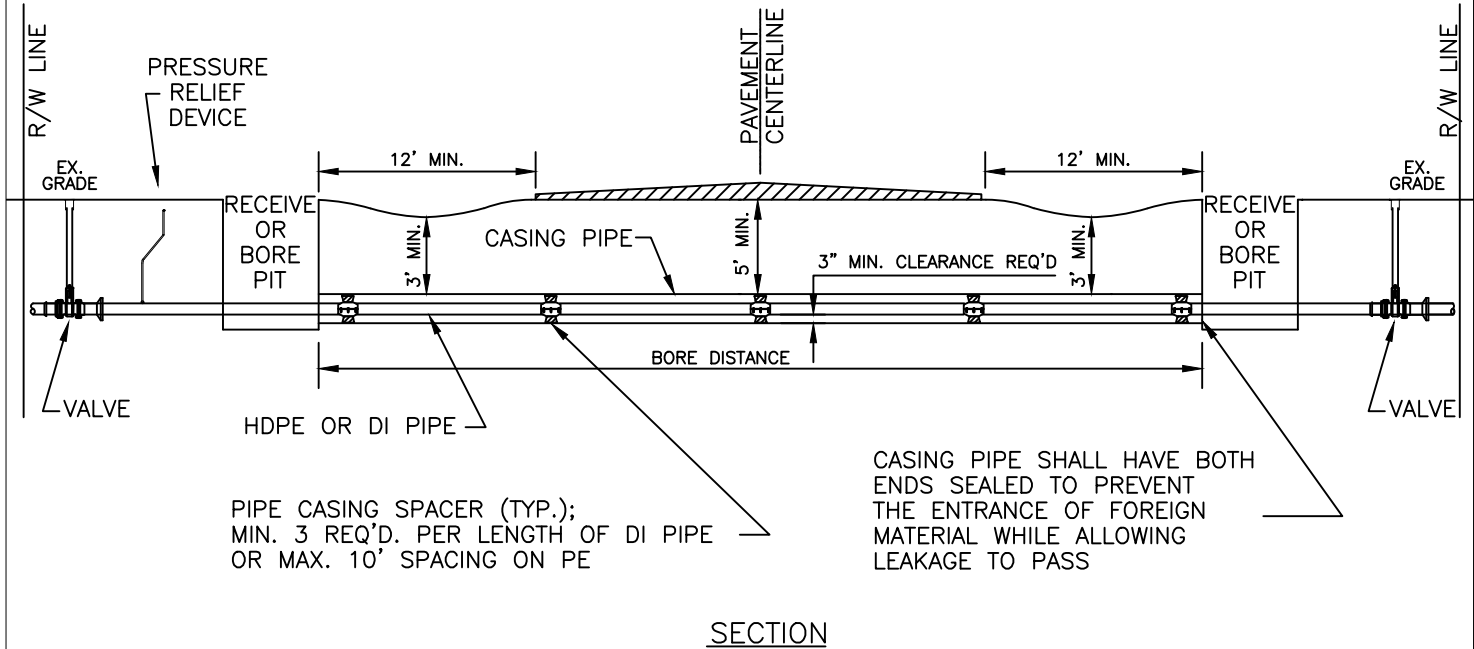

- NOTES:
1. ALL JOINTS IN CASING PIPE SHALL BE RESTRAINED.
 2. STEEL CASING SECTIONS SHALL BE CONNECTED BY WELDING. WELD SHALL BE IN ACCORDANCE WITH AWWA C206.
 3. POLYETHYLENE CASING SHALL BE CONNECTED BY WELDING.
 4. TRACING STATIONS SHALL BE INSTALLED ON EACH END OF CASING
 4. LOCATION & TYPE OF PRESSURE RELIEF DEVICE TO BE DETERMINED BY THE UTILITY.

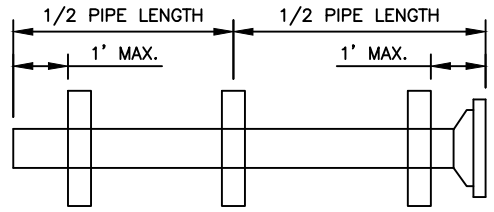

DI PIPE CASING SPACER DETAIL

CITIZENS WATER STANDARD PRACTICE

J

REVISION DATE: 4/24/2008

ISSUE DATE: 6/8/2009

2" BLOW-OFF ASSEMBLY FOR 3" THROUGH 8" MAIN

NOTE: DECHLORINATION BAG & TABLETS REQUIRED WHILE FLUSHING

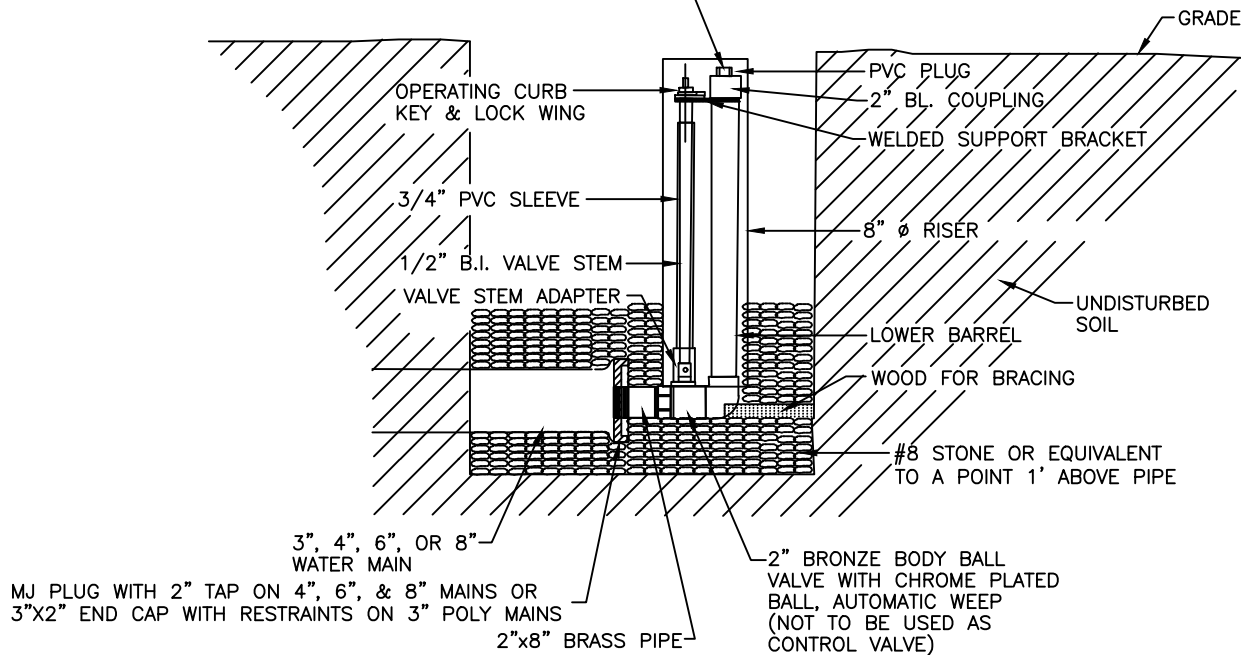
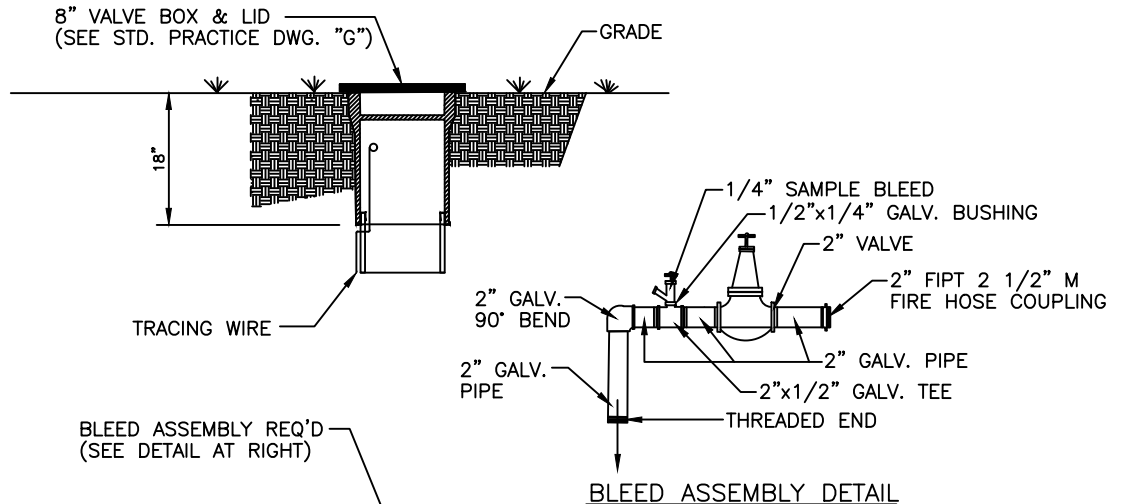

SECTION

CITIZENS WATER
STANDARD PRACTICE

K

REVISION DATE: 4/24/2008

ISSUE DATE: 6/8/2009

2" BLOW-OFF ASSEMBLY FOR 12", 16", 20", and 24" MAIN

NOTE: DECHLORINATION BAG & TABLETS REQUIRED WHILE FLUSHING

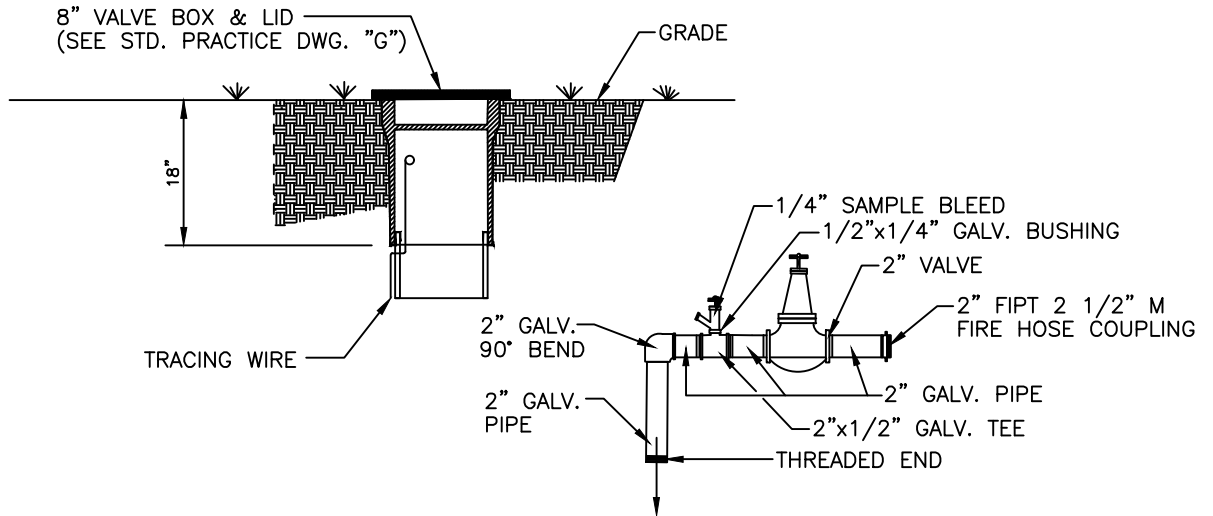

BLEED ASSEMBLY DETAIL

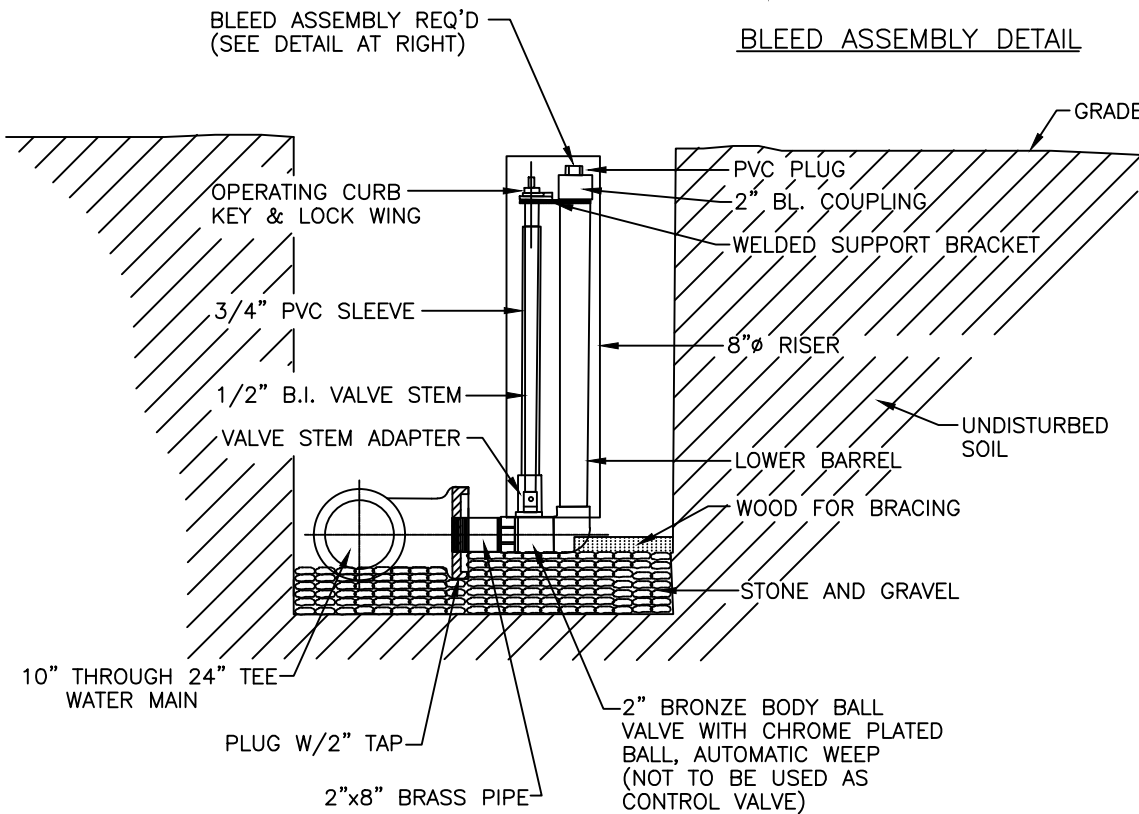

SECTION

CITIZENS WATER
STANDARD PRACTICE



REVISION DATE: 3/2/2016

ISSUE DATE: 6/8/2009

STANDARD HYDRANT/BLOW OFF BLEED

NOTE: SECURE APPARATUS & FULLY OPEN HYDRANT, USE 2" VALVE AS THE CONTROL VALVE. A MANUFACTURED "OUT OF SERVICE" SIGN WILL BE REQUIRED ON HYDRANTS UNTIL MAIN HAS BEEN PLACED "IN SERVICE" BY THE INSPECTOR. DECHLORINATION BAG & TABLETS REQUIRED WHILE FLUSHING.

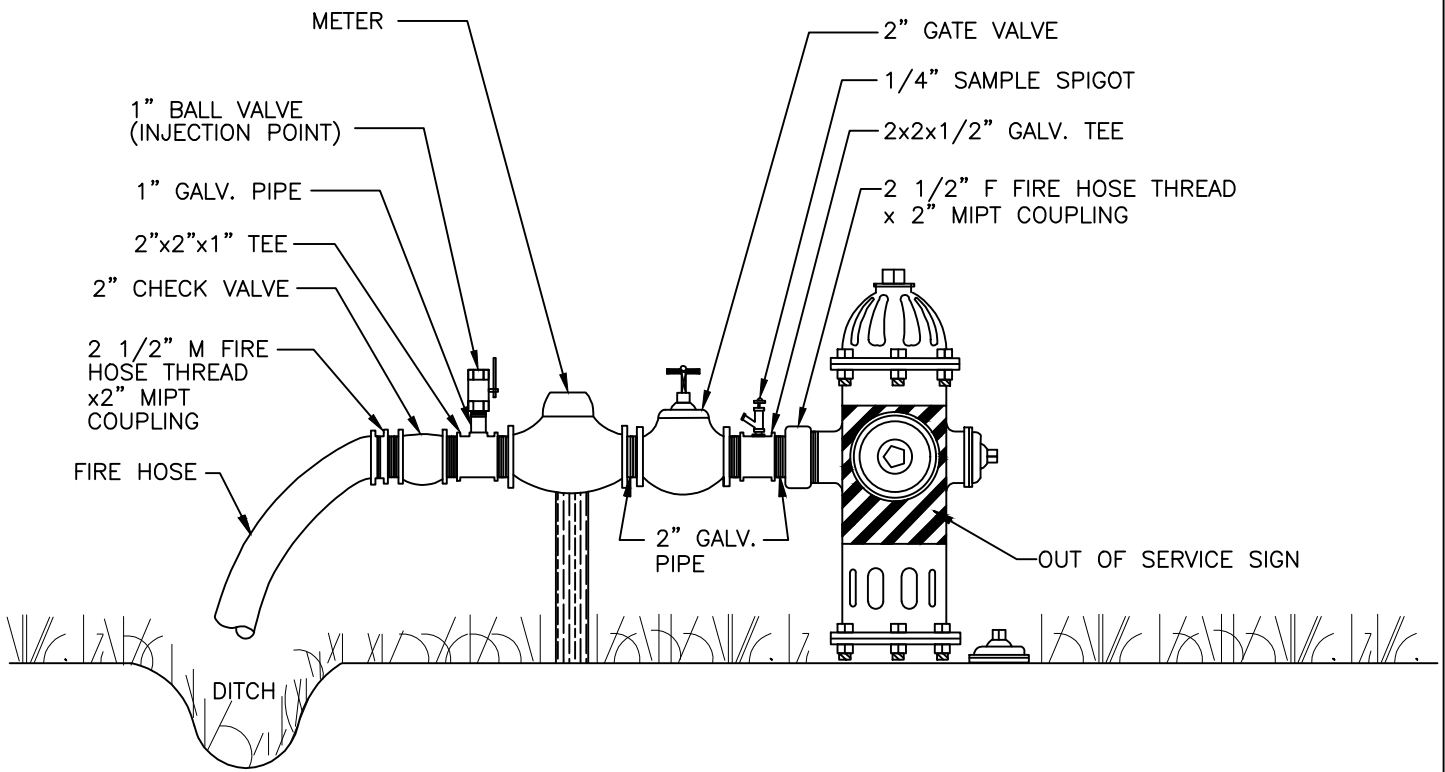

ELEVATION

CITIZENS WATER
STANDARD PRACTICE

L.1

REVISION DATE:

ISSUE DATE: 1/4/2012

STANDARD HYDRANT TO BLOW-OFF BLEED

****NOT REQUIRED FOR CITIZENS WESTFIELD****

NOTE: SECURE APPARATUS & FULLY OPEN HYDRANT, USE 2" VALVE AS THE CONTROL VALVE. A MANUFACTURED "OUT OF SERVICE" SIGN WILL BE REQUIRED ON HYDRANTS UNTIL MAIN HAS BEEN PLACED "IN SERVICE" BY THE INSPECTOR. DECHLORINATION BAG & TABLETS REQUIRED WHILE FLUSHING.

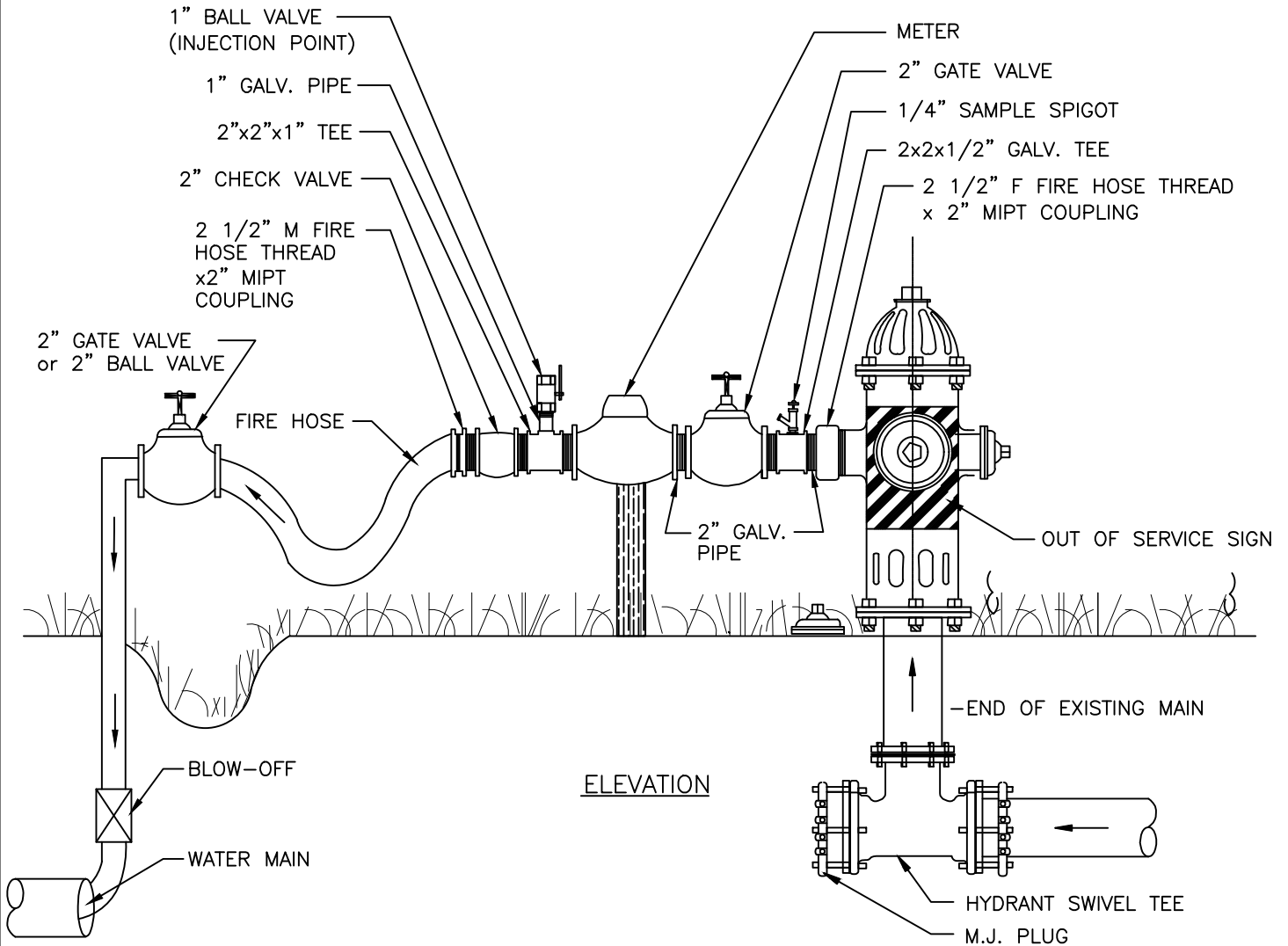

CITIZENS WATER
STANDARD PRACTICE

L.2

REVISION DATE:

ISSUE DATE: 1/4/2012

BLOW-OFF FEED TO BLOW-OFF BLEED

****NOT REQUIRED FOR CITIZENS WESTFIELD****

NOTE: ALL MAINS 12" OR LARGER REQUIRE CHLORINATION. A 2"x1" GALVANIZED TEE AND 1" PLUG IS REQUIRED FOR THE UTILITY TO CHLORINATE MAIN(S).

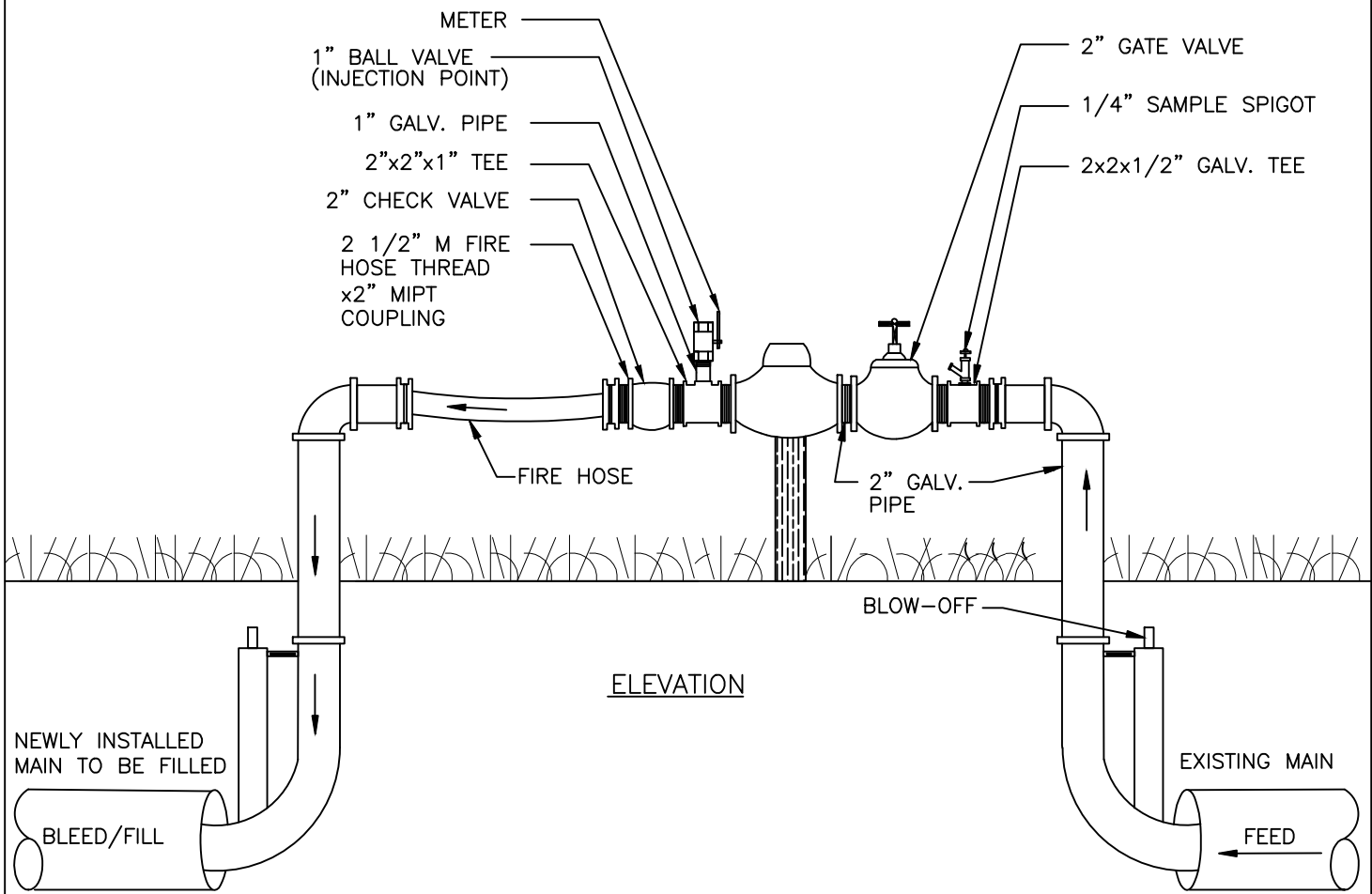

CITIZENS WATER
STANDARD PRACTICE

L.3

REVISION DATE: 11/6/2018

ISSUE DATE: 1/1/2015

STANDARD FLUSHING

NOTES:

1. THIS STANDARD IS TO BE USED IN WESTFIELD SERVICE TERRITORY. IT MAY BE UTILIZED IN CITIZENS WATER TERRITORY WITH APPROVAL DURING PLAN REVIEW.
2. WATER MUST BE METERED DURING FLUSHING.

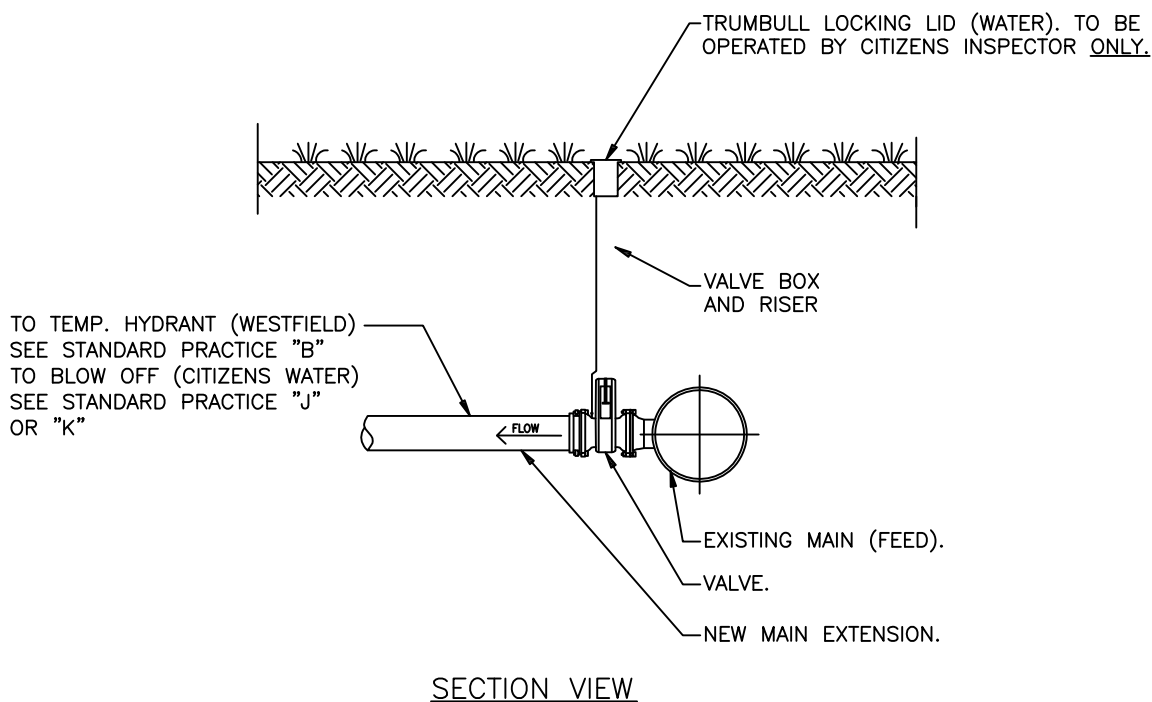

CITIZENS WATER
STANDARD PRACTICE

L.4

REVISION DATE:

ISSUE DATE: 3/2/2016

UNIVERSAL HYDRANT METER SET UP

NOTE: SECURE APPARATUS & FULLY OPEN HYDRANT, USE 2" VALVE AS THE CONTROL VALVE.
A MANUFACTURED "OUT OF SERVICE" SIGN WILL BE REQUIRED ON HYDRANTS UNTIL MAIN HAS BEEN PLACED "IN SERVICE" BY THE INSPECTOR.
DECHLORINATION BAG & TABLETS REQUIRED WHILE FLUSHING.

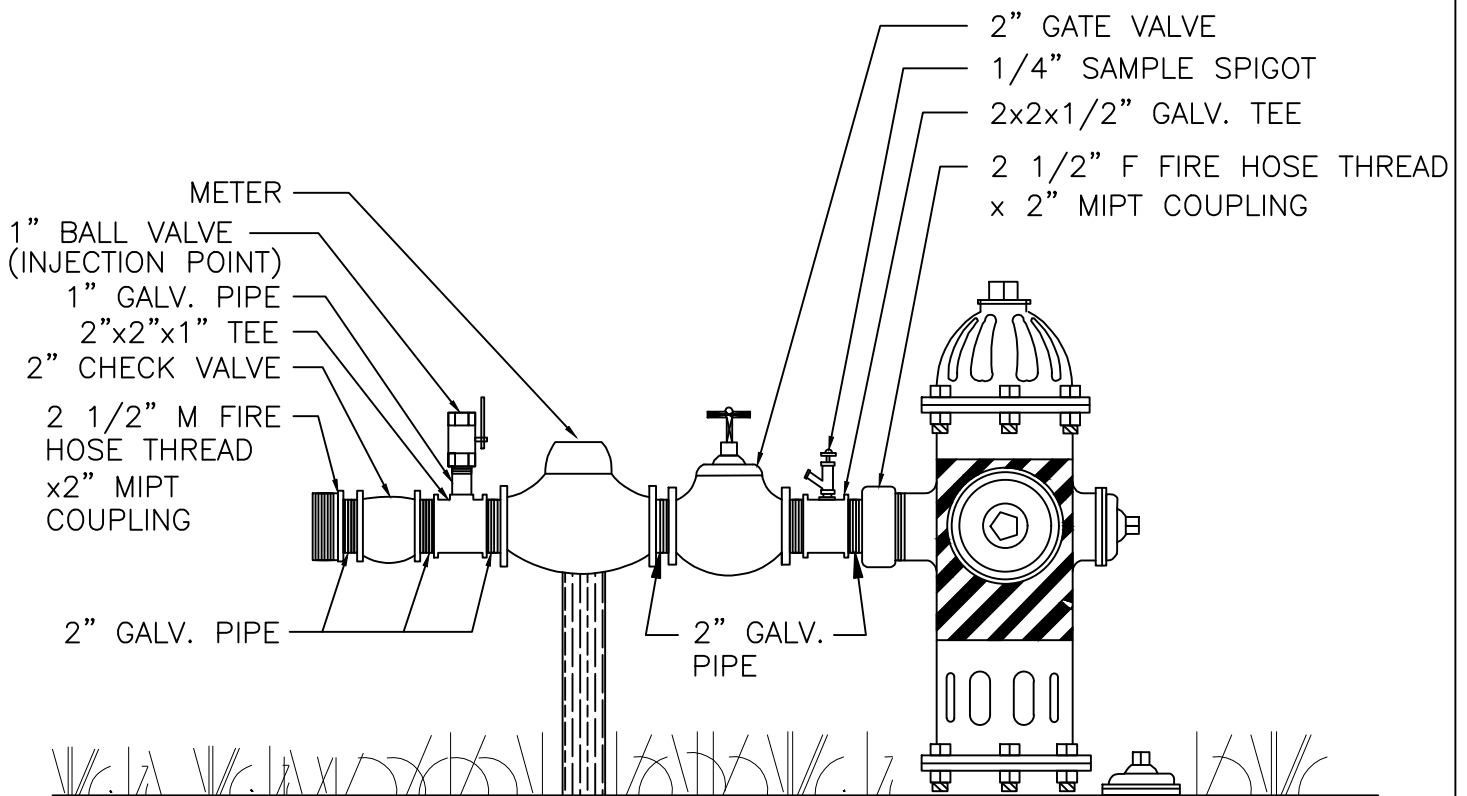

ELEVATION

CITIZENS WATER STANDARD PRACTICE

M

REVISION DATE: 10/20/2020

ISSUE DATE: 6/8/2009

AIR RELIEF APPARATUS FOR WATER MAINS

| TYPICAL MATERIAL LIST | | |
|---------------------------------|---------|--------------|
| MATERIAL | SIZE | QTY |
| METER PIT RISER | 20"x48" | 1 |
| STANDARD METER PIT COMPLETE | | 1 |
| PVC TUBING | 1/2" | 10' |
| 90° ELL PVC | 1/2" | 4 |
| FUSE-A-CORP | VAR x1" | 1 |
| AIR RELIEF VALVE (AS SPECIFIED) | | 1 |
| CHECK VALVE | 1/2" | 1 |
| AUTO DRAIN | 1/2" | 1 |
| POLYETHYLENE TUBING | 1" | FEILD VERIFY |
| COPPER TUBING | 1" | FEILD VERIFY |
| CURB STOP COPPER | 1" | 1 |
| BRASS BUSHING | 1" x 1" | 2 |
| BRASS NIPPLE | 1/2" | 1 |
| PVC TO MI CPLG | 1/2" | 1 |
| PVC PIPE | 4"x72" | 2 |
| ROAD BOX & LID | 5 1/4" | 1 |

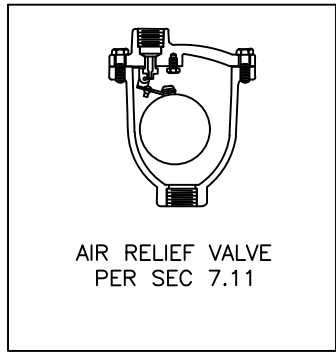
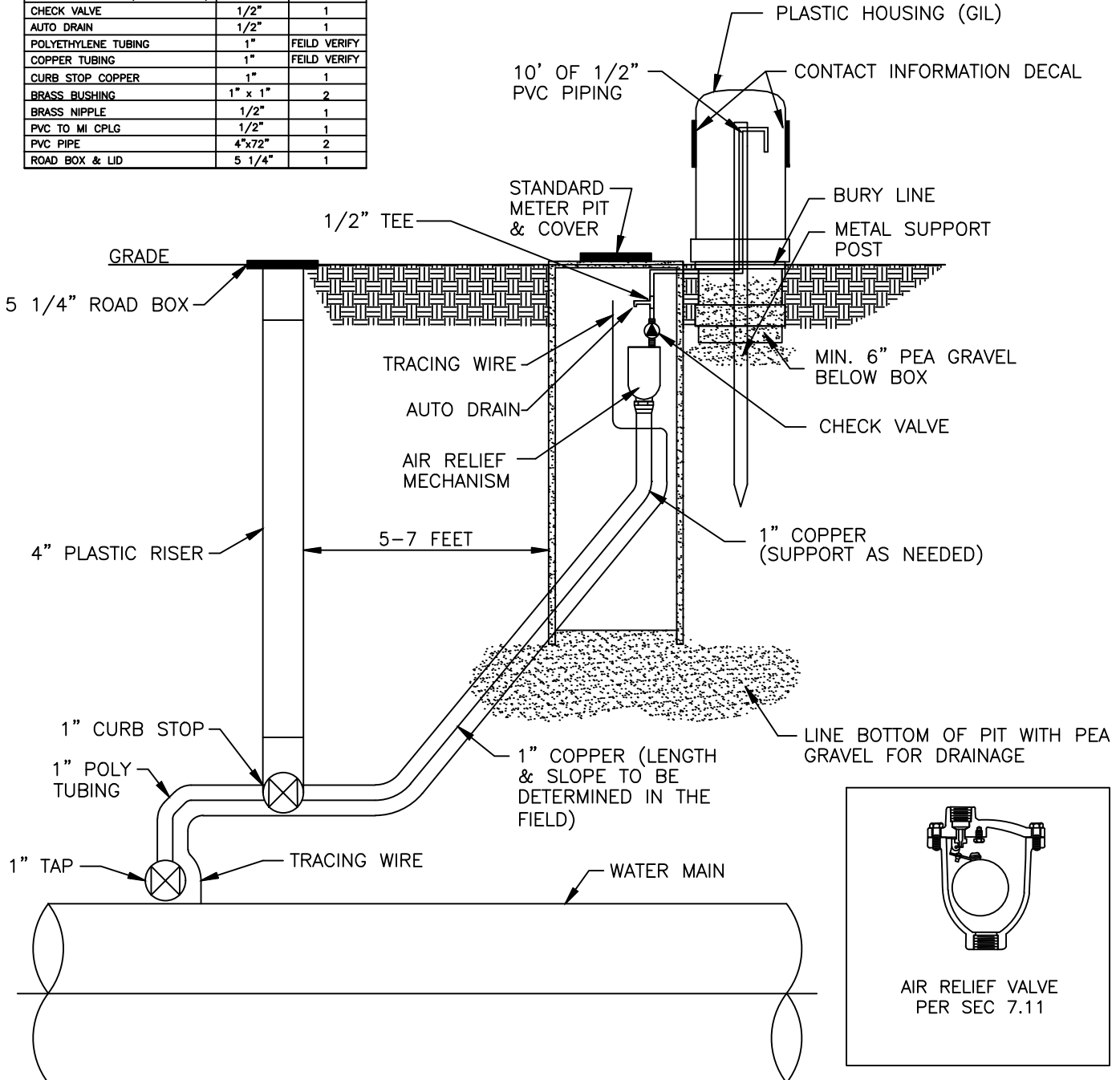

CITIZENS WATER
STANDARD PRACTICE

N

REVISION DATE: 7/25/2018

ISSUE DATE: 6/8/2009

1-1/2" & 2" SERVICE LINE
SWING JOINT

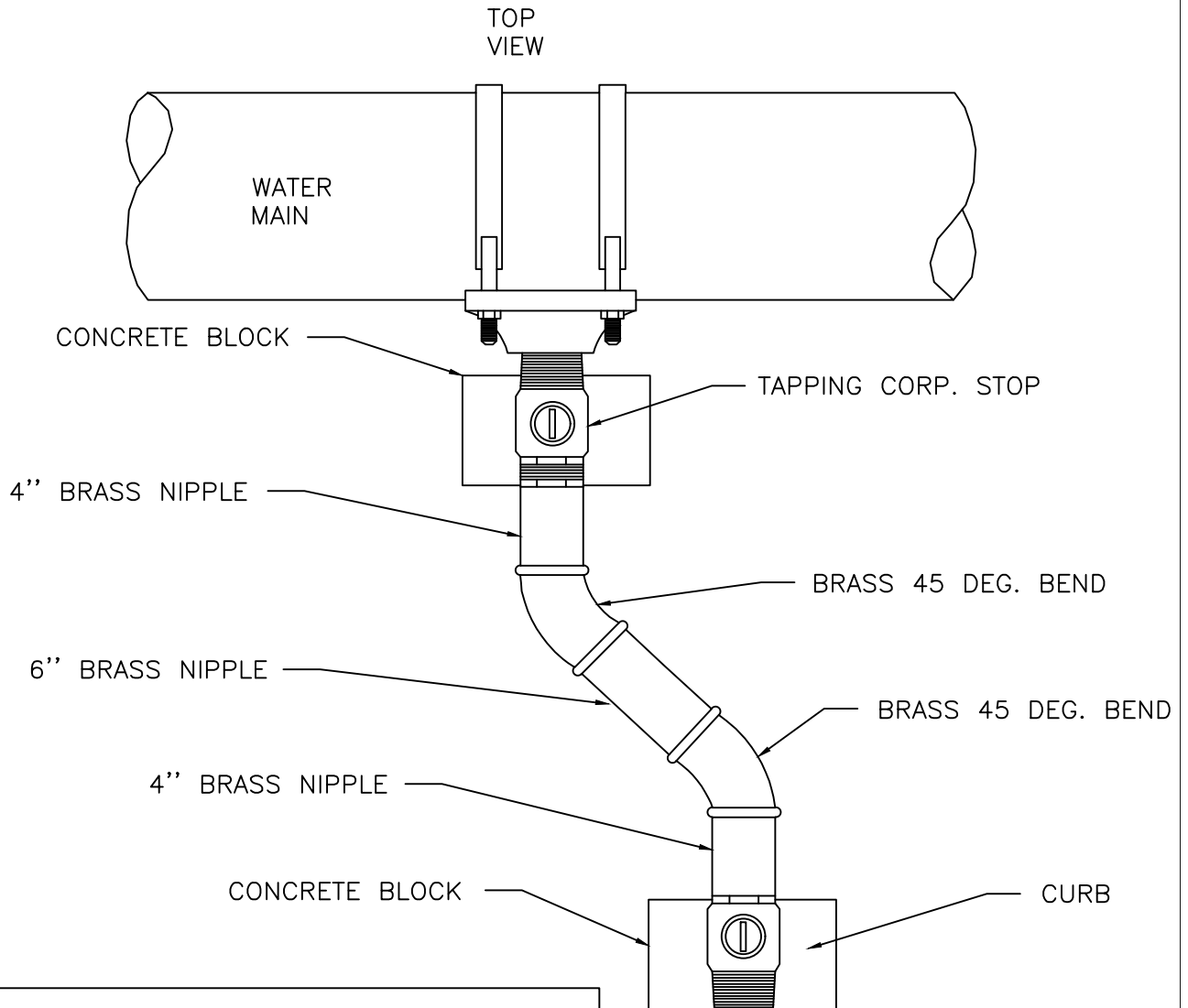

NOTES:

- 1) ALL SIZE DI, CI, AND PVC MAINS REQUIRE A TAPPING SADDLE
- 2) ALL SIZE POLY MAINS REQUIRE A FUSED ON TAPPING SADDLE FOR 1-1/2" AND 2" SERVICE LINES
- 3) SADDLE AND TAPPING CORP. STOP SUPPLIED & INSTALLED BY CEG. THIS MATERIAL WILL NOT BE SUPPLIED ON DEVELOPER PROJECTS.
- 4) ALL TAP EXCAVATIONS ARE REQUIRED TO BE BACKFILLED WITH GRANULAR OR FLOWABLE FILL TO A POINT 1'-0" ABOVE WATER MAIN
- 5) SWING JOINT DIRECTION MUST NOT DEVIATE FROM DRAWING
- 6) A COMPRESSION FITTING MUST BE USED OUT OF CURB STOP TO SERVICE LINE
- 7) STIFFENERS MUST BE USED ON ALL POLY SERVICES
- 8) 4" PLASTIC RISER W/ 5-1/4" VALVE BOX MUST BE INSTALLED OVER CURB STOP AND RESTING ON CONCRETE BLOCK
- 9) POLY SERVICES REQUIRE A TRACER WIRE WHICH SHOULD BE ROUTED ON THE OUTSIDE OF THE 4" RISER THEN STUBBED INSIDE THE RISER AT THE TOP. VERIFY THIS WIRE DOES NOT INTERFERE WITH THE OPERATION OF THE CURB STOP.

CITIZENS WATER STANDARD PRACTICE



REVISION DATE: 3/20/2014

ISSUE DATE: 6/8/2009

INSTALLATION OF RESTRAINTS

MAIN ENDING WITH BLOW-OFF ASSEMBLY OR HYDRANT

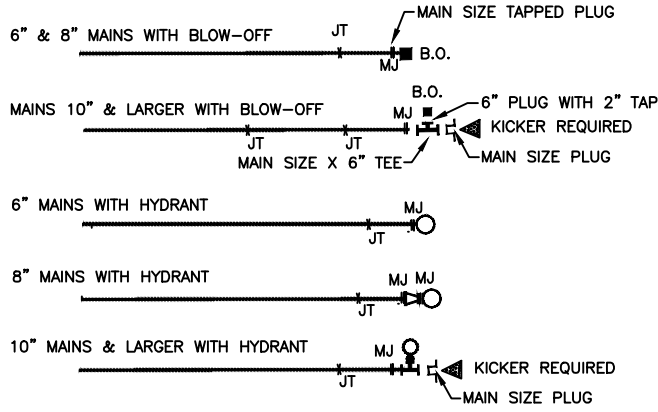

1 JOINT RESTRAINT & 1 MECHANICAL JOINT RESTRAINT
MIN. 30'

IN-LINE FITTINGS

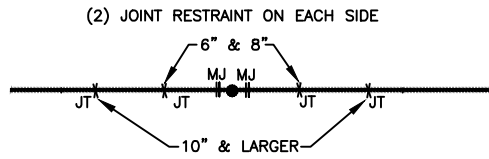

(2) JOINT RESTRAINTS AND (1) MECH. JOINT RESTRAINT ON EACH SIDE

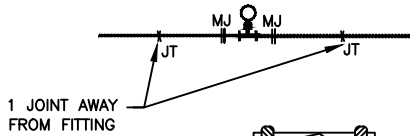

DUCTILE IRON JOINT RESTRAINT DETAIL

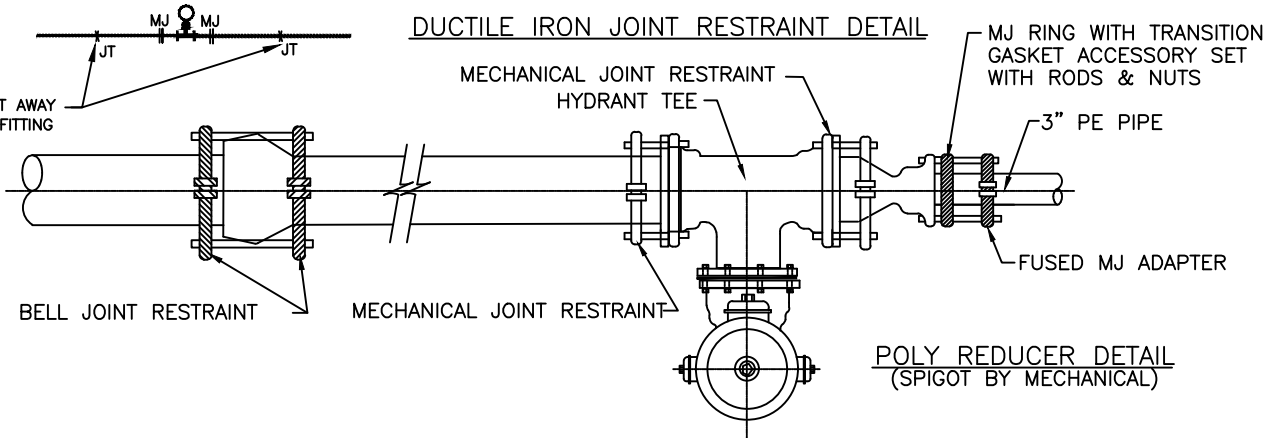

POLY REDUCER DETAIL (SPIGOT BY MECHANICAL)

PVC JOINT RESTRAINT DETAIL

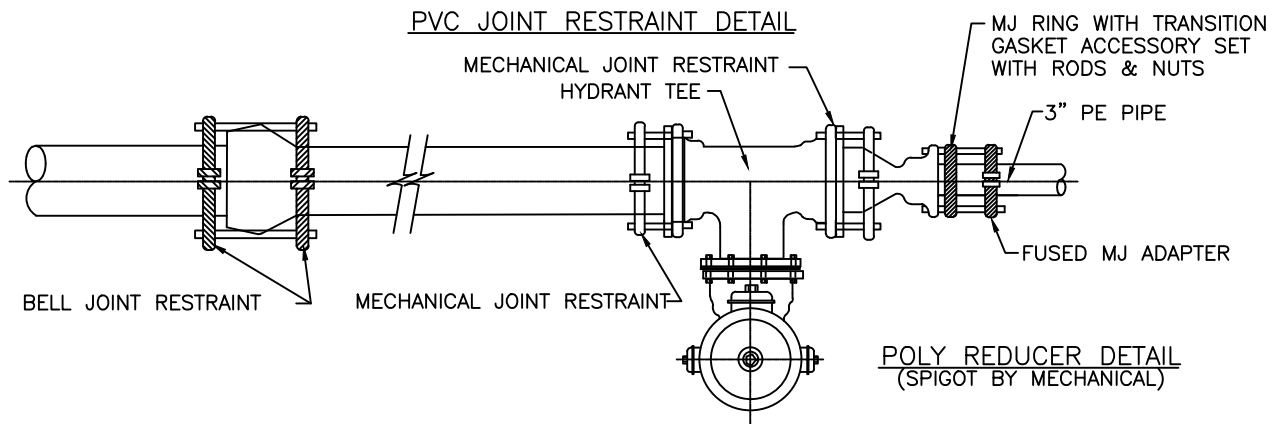

POLY REDUCER DETAIL (SPIGOT BY MECHANICAL)

BEND RESTRAINT

1. ALL BENDS REQUIRE RESTRAINERS.
2. ALL BENDS ARE DUCTILE IRON AND REQUIRE (1) MECHANICAL JOINT RESTRAINT ON EACH SIDE OF THE FITTING.
3. 22 1/2° BENDS REQUIRE ONLY MECHANICAL JOINT RESTRAINTS AND 45° BENDS REQUIRE MECHANICAL JOINT RESTRAINTS AND A SET OF JOINT RESTRAINTS 40° EACH SIDE OF THE FITTING.
4. THRUST BLOCK REQUIRED ON ALL 45° & 90° BENDS.

MAIN LINE REDUCER

- 6" & 8": USE 1 MECHANICAL JOINT RESTRAINT & 1 JOINT RESTRAINER
⊙ MIN. 20' ON EACH SIDE OF REDUCER.



- 10" & LARGER: USE 2 JOINT RESTRAINERS ON THE LARGER SIDE
⊙ MIN. 20' ON THE SMALL SIDE ⊙ MIN. 20'.

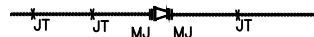

FITTING RESTRAINT WITH PE PIPE

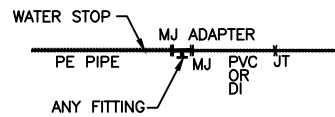

VEHICLE IMPACT PROTECTION FOR HYDRANTS

ADOPTED CODE FOR THE STATE OF INDIANA, TAKEN FROM THE 2006 INTERNATIONAL FIRE CODE.

SECTION 312 VEHICLE IMPACT PROTECTION

312.1 GENERAL. VEHICLE IMPACT PROTECTION REQUIRED BY THIS CODE SHALL BE PROVIDED BY POSTS THAT COMPLY WITH SECTION 312.2 OR BY OTHER APPROVED PHYSICAL BARRIERS THAT COMPLY WITH SECTION 312.3.

312.2 POSTS. GUARD POSTS SHALL COMPLY WITH ALL OF THE FOLLOWING REQUIREMENTS:

1. CONSTRUCTED OF STEEL NOT LESS THAN 4 INCHES (102 MM) IN DIAMETER AND CONCRETE FILLED.
2. SPACED NOT MORE THAN 4 FEET (1219 MM) BETWEEN POSTS ON CENTER.
3. SET NOT LESS THAN 3 FEET (914 MM) DEEP IN A CONCRETE FOOTING OF NOT LESS THAN A 15-INCH (381 MM) DIAMETER.
4. SET WITH THE TOP OF THE POSTS NOT LESS THAN 3 FEET (914 MM) ABOVE GROUND.
5. LOCATED NOT LESS THAN 3 FEET (914 MM) FROM THE PROTECTED OBJECT

312.3 OTHER BARRIERS. PHYSICAL BARRIERS SHALL BE A MINIMUM OF 36 INCHES (914 MM) IN HEIGHT AND SHALL RESIST A FORCE OF 12,000 POUNDS (53 375 N) APPLIED 36 INCHES (914 MM) ABOVE ADJACENT GROUND SURFACE.

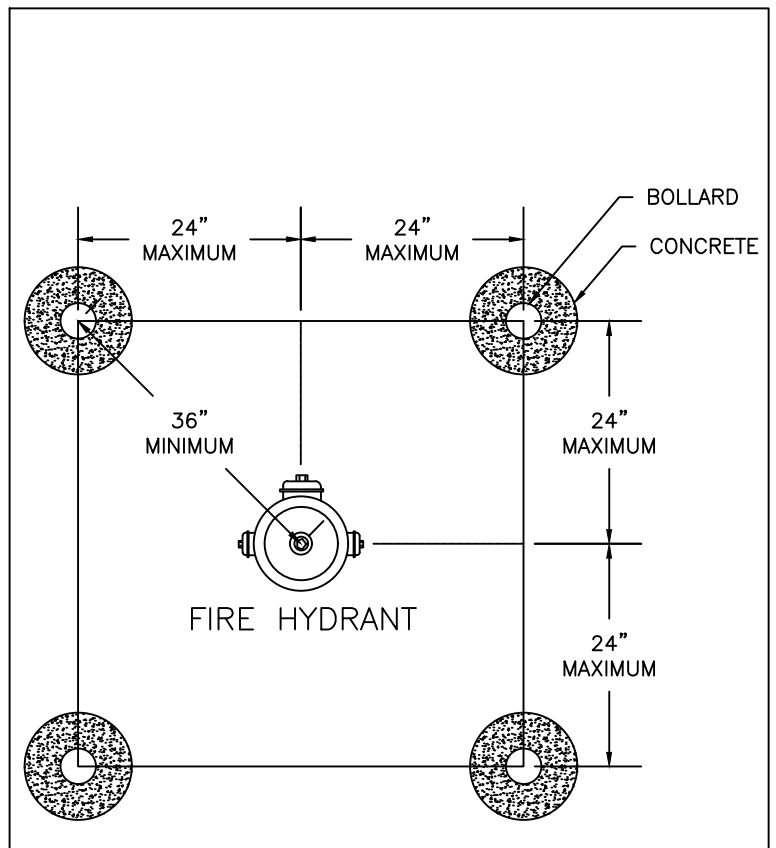
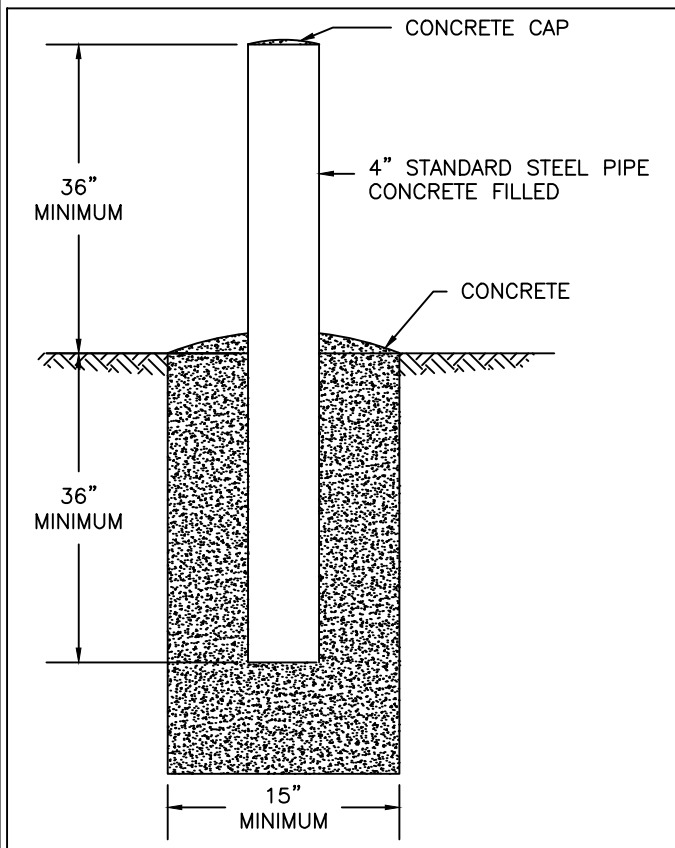

CITIZENS WATER
STANDARD PRACTICE

P

REVISION DATE: 10/20/2020

ISSUE DATE: 6/8/2009

SAMPLING STATION STANDARD ARRANGEMENT

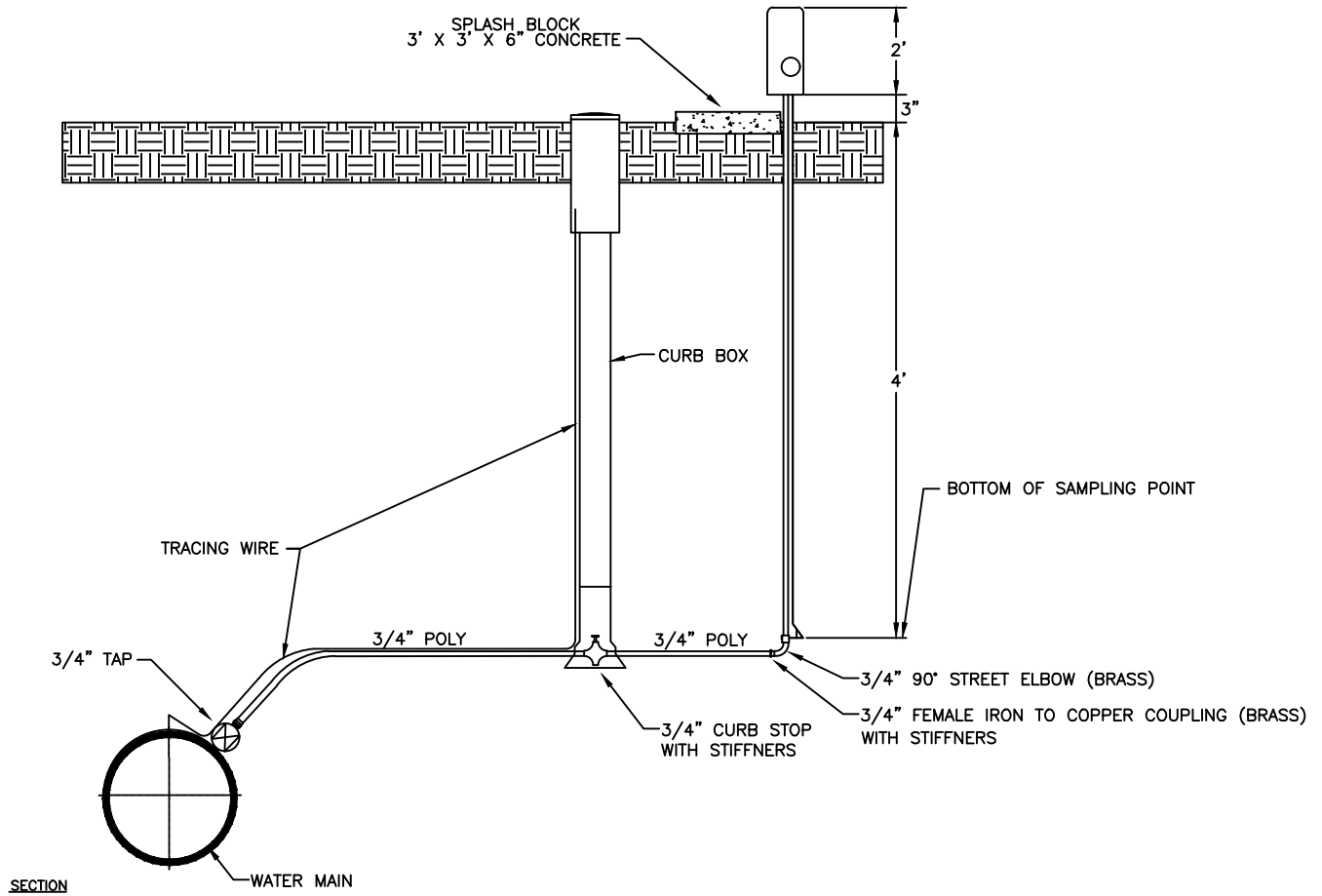

CITIZENS WATER
STANDARD PRACTICE

Q

REVISION DATE: 1/15/2007

ISSUE DATE: 6/8/2009

MAIN INSTALLATION BETWEEN PROPERTIES

IN AREAS WHERE A MAIN MUST BE INSTALLED IN AN EASEMENT OR COMMON AREA THAT RUNS BETWEEN TWO OR MORE PROPERTIES, WELDED HIGH DENSITY POLYETHYLENE PIPE IS REQUIRED. THE INSTALLATION MUST TRAVERSE THE ENTIRE EASEMENT, COMMON AREA OR LOT AND SHALL BE INSTALLED AS ON CONTINUOUS PIPE WITH A VALVE LOCATED AT EACH END. THIS INSTALLATION WILL TYPICALLY GO FROM RIGHT-OF-WAY TO RIGHT-OF-WAY. NO TAPS WILL BE PERMITTED ON THIS SECTION OF MAIN. ALL TAPS MUST OCCUR WITHIN THE LIMITS OF THE RIGHT-OF-WAY AND NOT BETWEEN THE PROPERTIES. A MINIMUM 15' EXCLUSIVE CITIZENS WATER EASEMENT OR 30' NON-EXCLUSIVE EASEMENT WILL BE REQUIRED FOR INSTALLATION. NOTE ADDITIONAL VALVES MAY BE REQUIRED TO ISOLATE SECTION.



CITIZENS WATER
STANDARD PRACTICE

R

REVISION DATE: 1/15/2007

ISSUE DATE: 6/8/2009

TRACING STATION

5-INCH CAST IRON VALVE BOX COVER

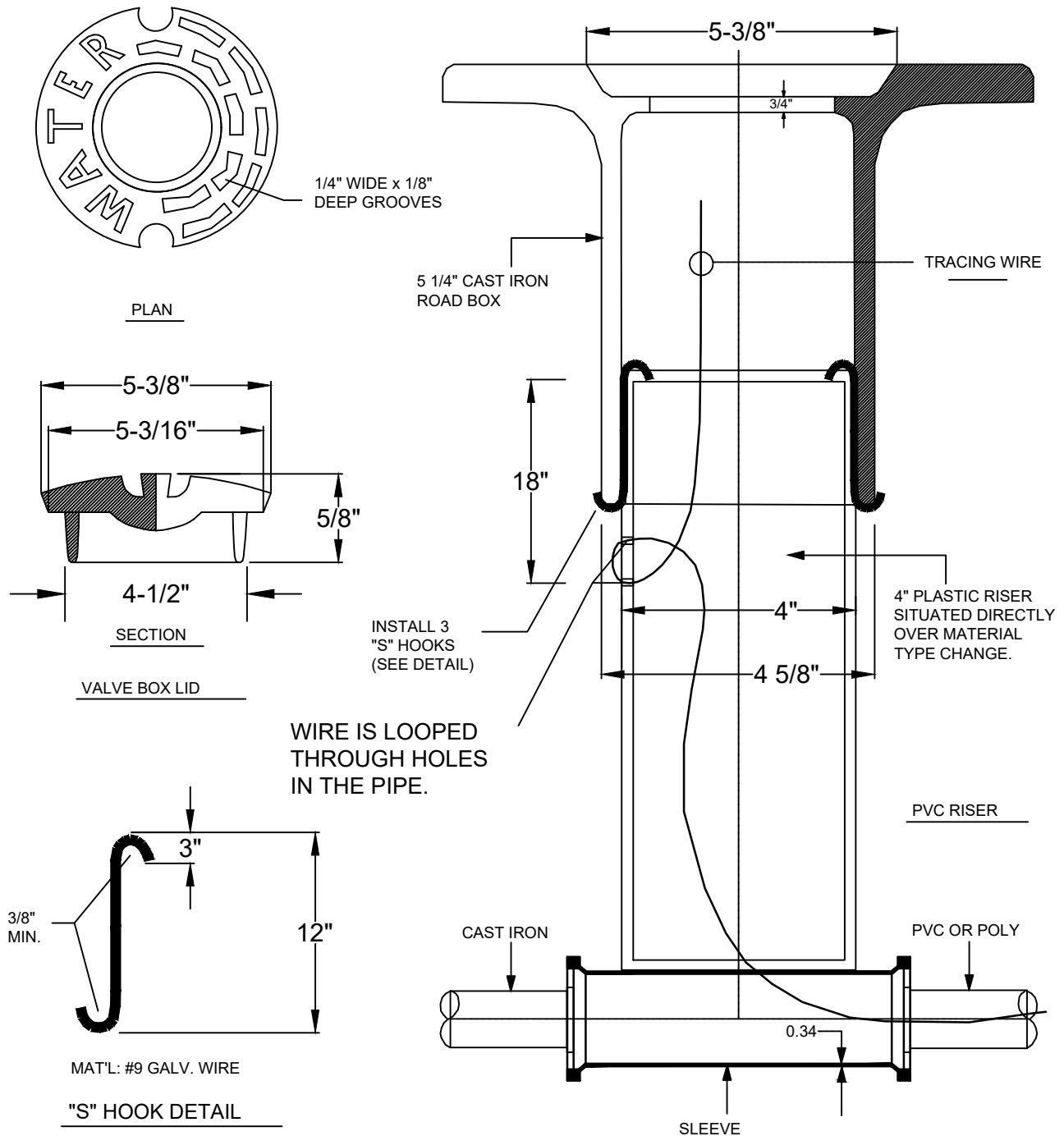

CITIZENS WATER STANDARD PRACTICE

S

REVISION DATE: 01/15/2007

ISSUE DATE: 6/8/2009

STANDARD INSTALLATION FOR MULTIPLE METER SETTINGS

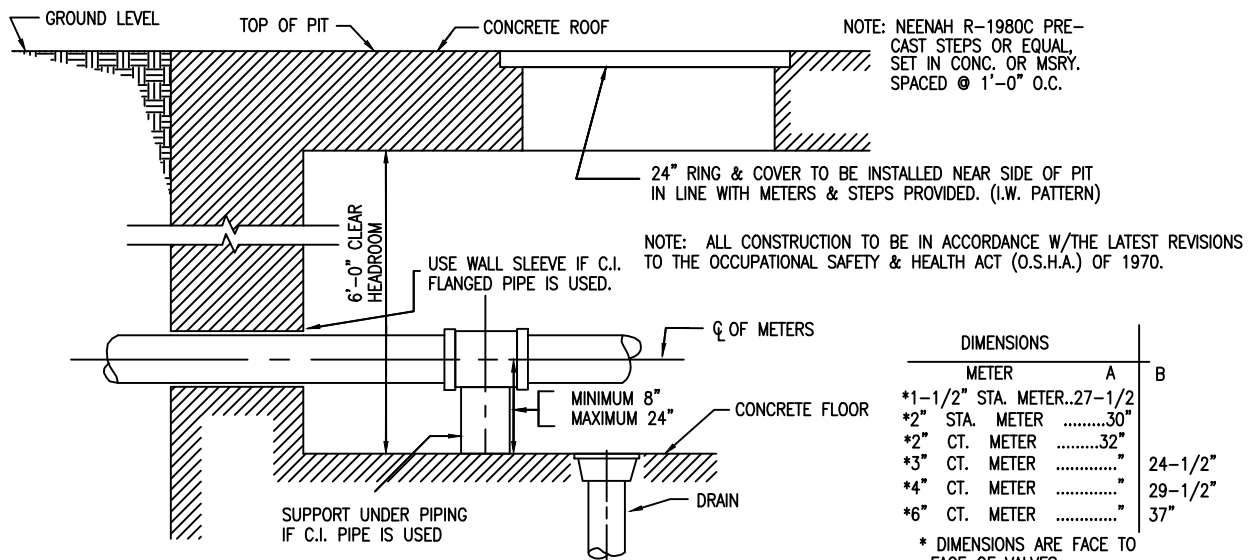
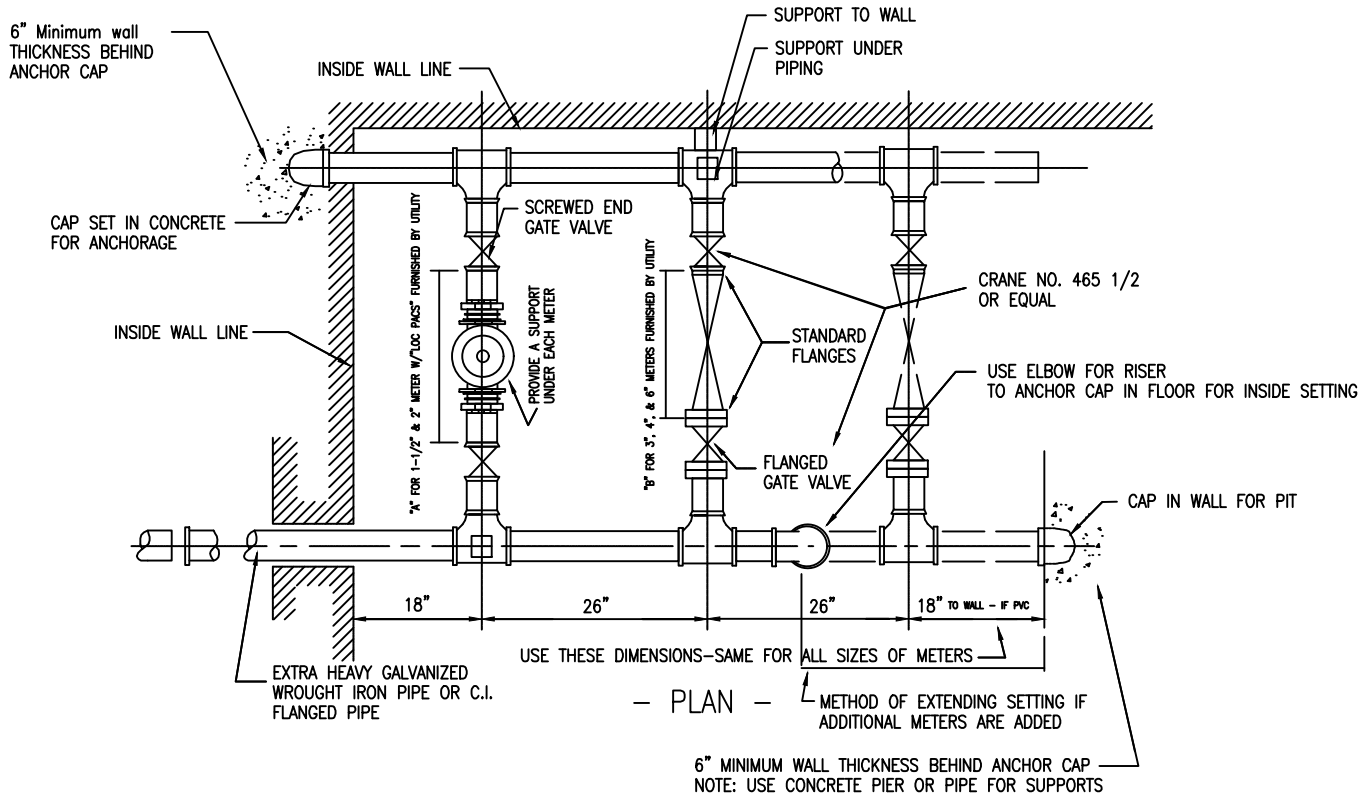

| DIMENSIONS | | |
|----------------------|---------|---------|
| METER | A | B |
| *1-1/2" STA. METER.. | 27-1/2" | |
| *2" STA. METER | 30" | |
| *2" CT. METER | 32" | 24-1/2" |
| *3" CT. METER | " | 29-1/2" |
| *4" CT. METER | " | 37" |
| *6" CT. METER | " | |

* DIMENSIONS ARE FACE TO FACE OF VALVES.

THE METER PIT, PIPING, VALVES, AND FITTINGS ARE FURNISHED AND INSTALLED BY THE CUSTOMER. THE METER ONLY IS FURNISHED & SET BY CITIZENS WATER.

CITIZENS WATER STANDARD PRACTICE

T

REVISION DATE: 10/20/2020

ISSUE DATE: 12/31/2019

STANDARD SERVICE LINE INSTALLATION AND SETTING FOR 5/8", 3/4", AND 1" METER IN SINGLE PIT

| ITEM | 5/8" & 3/4" METERS | 1" METERS |
|--------------------------------|---|--|
| METER PIT COVER | DFW PLASTICS, INC. PART #DFW12FTV-1WLA-LID w/ FORD METER BOX, INC. 20" x 24" METAL EXPANSION RING AND 20" LINER, OR APPROVED EQUAL. 11.5" DIA. LID w/ LG. PENT OPENING NUT. | DFW PLASTICS, INC. PART #DFW12FTV-1WLA-LID w/ FORD METER BOX, INC. 20" x 24" METAL EXPANSION RING AND 24" PIT LINER, OR APPROVED EQUAL. 4" DEPTH, 11.50" DIA. LID w/ LG. PENT OPENING NUT. |
| PIT | 20X48" PLASTIC RISER: MIDSTATES PLASTICS, FRANCISVILLE TILE (FRATCO) OR APPROVED EQUAL | 24X48" PLASTIC RISER: MIDSTATES PLASTICS, FRANCISVILLE TILE (FRATCO) OR APPROVED EQUAL |
| SUPPORT | SINGLE METER SUPPORT PER STANDARD PRACTICE Z. | SINGLE METER SUPPORT PER STANDARD PRACTICE Z. |
| YOKE | FORD 501-P PRONGED YOKE FOR 5/8" METERS OR APPROVED EQUAL, FORD 503-P PRONGED YOKE FOR 3/4" METERS OR APPROVED EQUAL. | FORD 504P PRONGED YOKE FOR 1" METERS OR APPROVED EQUAL. |
| VALVES: INLET SIDE (FROM MAIN) | [5/8"]: 5/8" ANGLE VALVE w/LOCK & 3/4" COMPRESSION CONNECTION FOR CTS POLY TUBING. FORD #AV94-313WG OR APPROVED EQUAL. [3/4"]: 3/4" ANGLE VALVE w/LOCK & 1" COMPRESSION CONNECTION FOR CTS POLY TUBING. FORD #AV94-324W-G OR APPROVED EQUAL. | [1"]: 1" ANGLE VALVE w/ LOCK & 1 1/4" COMPRESSION CONNECTION FOR CTS POLY TUBING—A.Y. MCDONALD #4602YT 1-1/4 X 04 OR APPROVED EQUAL. |

| ITEM | 5/8" & 3/4" METERS | 1" METERS |
|---|---|---|
| VALVES: OUTLET SIDE (TO CUSTOMER) | [5/8"]: 5/8" GLOBE STYLE COMPRESSION VALVE w/ "T" OPERATING HANDLE & 3/4" COMPRESSION CONNECTION FOR CTS POLY TUBING —**FORD ONLY #GA94-313-G [3/4"]: 3/4" GLOBE STYLE COMPRESSION VALVE w/ "T" OPERATING HANDLE & 1" COMPRESSION CONNECTION FOR CTS POLY TUBING —**FORD ONLY #GA94-324-AWT-G | [1"]: 1" GLOBE STYLE COMPRESSION VALVE w/ "T" OPERATING HANDLE & 1 1/4" COMPRESSION CONNECTION FOR CTS POLY TUBING —**FORD ONLY #GA94-445-AWT-G |
| RISER SIZE & SERVICE LINE SIZE (TUBING LEADING TO AND FROM YOKE VALVES) | [5/8"]: 3/4" CTS SDR9 AWWA POLY TUBING [3/4"]: 1" CTS SDR 9 AWWA POLY TUBING ***MUST UTILIZE A STAINLESS STEEL INSERT STIFFENER AT ALL COMPRESSION CONNECTIONS WHEN USING CTS POLY TUBING IN ALL CASES 10 GA. SOLID THHN, BLUE SHELL TRACING WIRE MUST BE INSTALLED WITH THE POLY SERVICE LINE. | [1"]: 1 1/4" CTS SDR9 AWWA POLY TUBING ***MUST UTILIZE A STAINLESS STEEL INSERT STIFFENER AT ALL COMPRESSION CONNECTIONS IN ALL CASES 10 GA. SOLID THHN, BLUE SHELL TRACING WIRE MUST BE INSTALLED WITH THE POLY SERVICE LINE. |

NOTES:

1. METER FURNISHED & SET BY CITIZENS
2. YOKE INCLUDING ANGLE & COMPRESSION VALVES FURNISHED TO PLUMBER BY CITIZENS
3. ALL SERVICE LINES MUST HAVE 4' 1/2" OF COVER REGARDLESS OF THE WATER MAIN DEPTH. AT LEAST 2' OF FLOW, SAND OR PEA GRAVEL REQUIRED AT EACH TAP AND SERVICE LOCATION.
4. LOCATE METER PIT WITHIN 1'-3' OF ROW LINE ON CUSTOMER PROPERTY. THE LOCATION MUST BE ACCESSIBLE AND IN A LEVEL PLACE. THE PIT SHALL NOT BE LOCATED IN DRIVEWAYS.
5. SEE STANDARD PRACTICE DRAWING Z – POLYETHYLENE SERVICE LINE METER SUPPORT (SINGLE METER SET) FOR METER SUPPORT INFORMATION.

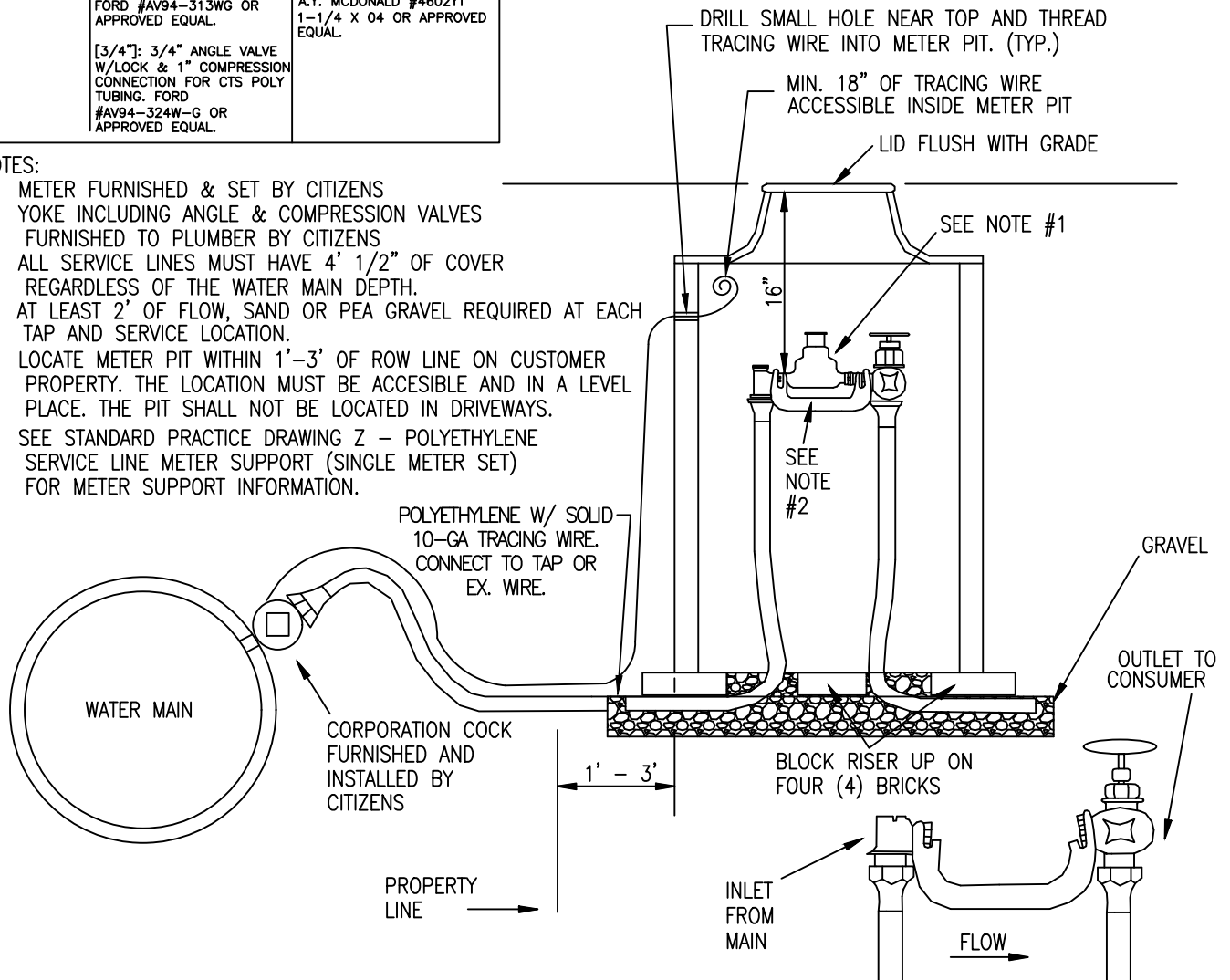

CITIZENS WATER
STANDARD PRACTICE

T.3

REVISION DATE: 05/19/2015

ISSUE DATE: 05/19/2015

SPLIT SERVICE LINE IN COMMON AREAS

IN COMMON AREAS OUTSIDE OF RIGHT-OF-WAY WHERE A SERVICE LINE MAY BE SPLIT OFF FROM A SINGLE METER PIT FOR THE PURPOSES OF IRRIGATION ONLY.

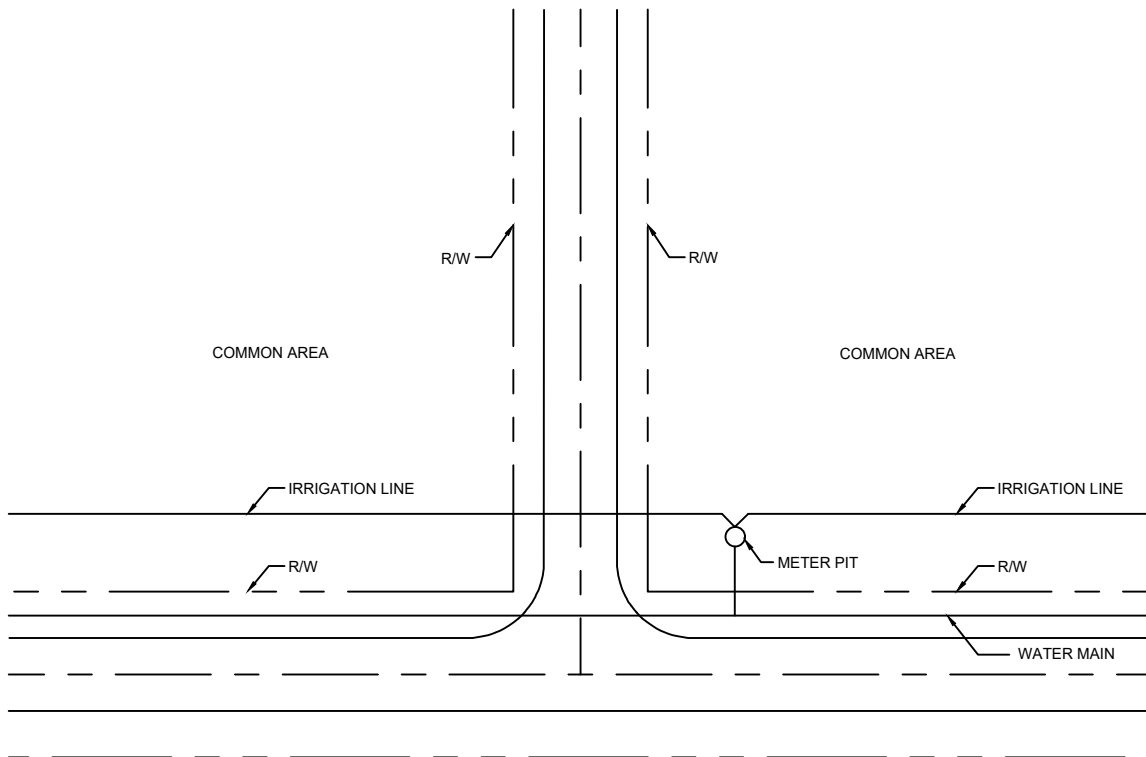

DUAL METER CONNECTION
WITH DUAL RPZ

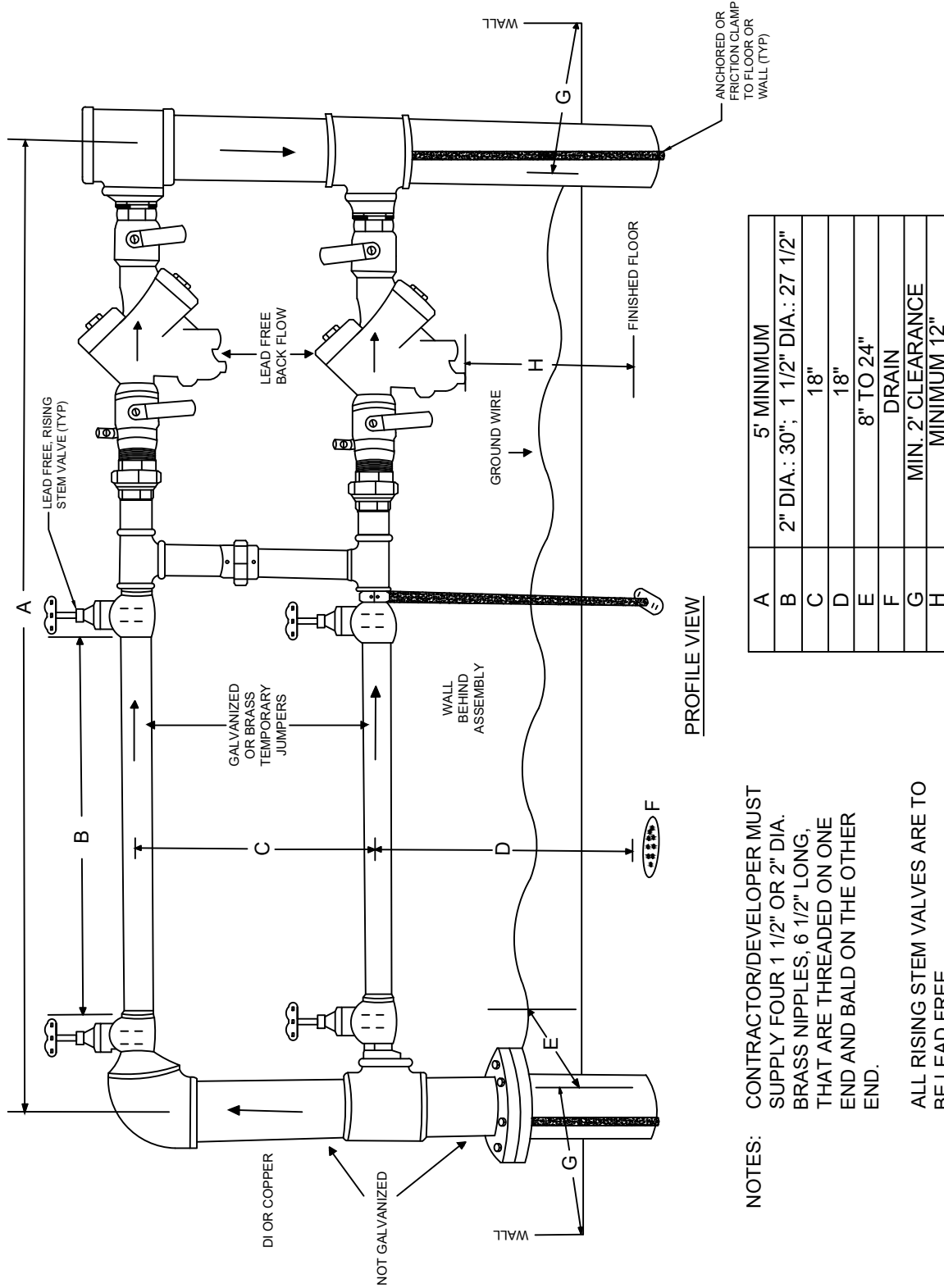

NOTES:

CONTRACTOR/DEVELOPER MUST SUPPLY FOUR 1 1/2" OR 2" DIA. BRASS NIPPLES, 6 1/2" LONG, THAT ARE THREADED ON ONE END AND BALD ON THE OTHER END.

ALL RISING STEM VALVES ARE TO BE LEAD FREE.

| | |
|---|------------------------------------|
| A | 5' MINIMUM |
| B | 2" DIA.: 30"; 1 1/2" DIA.: 27 1/2" |
| C | 18" |
| D | 18" |
| E | 8" TO 24" |
| F | DRAIN |
| G | MIN. 2' CLEARANCE |
| H | MINIMUM 12" |

IRRIGATION SYSTEM DISCONNECTION DETAIL

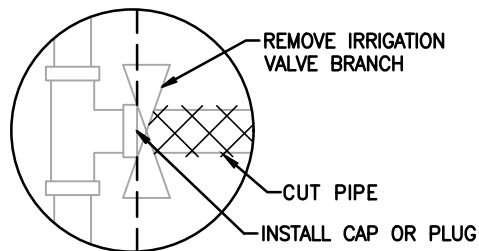
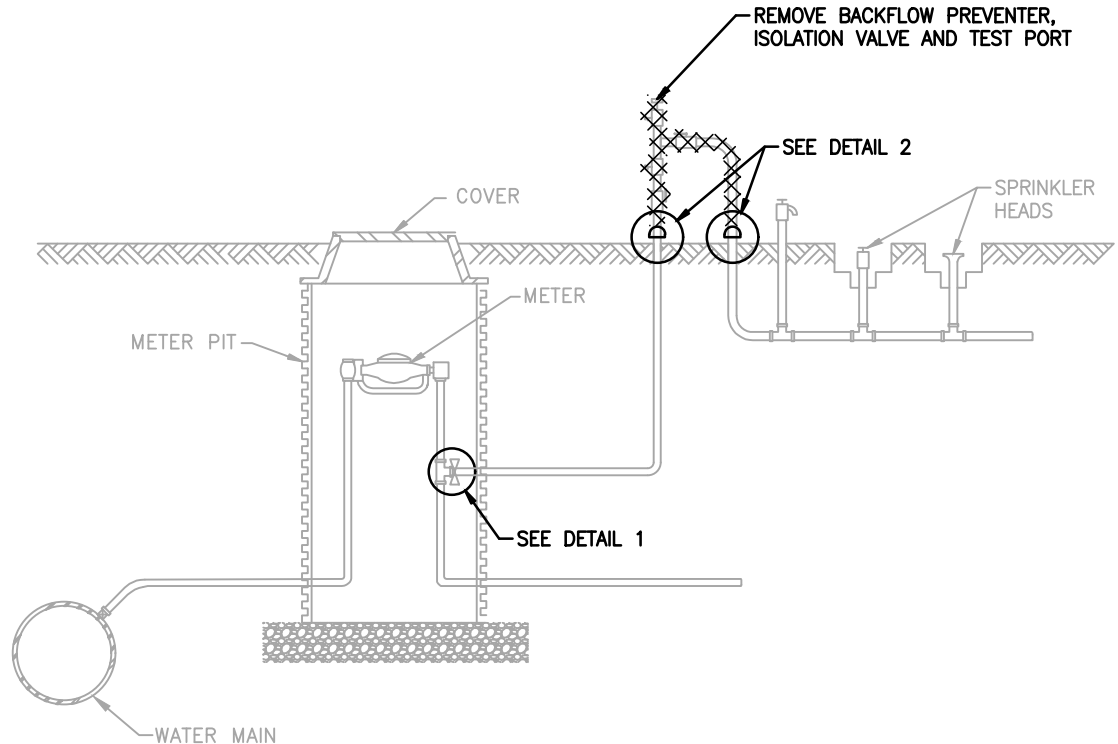

DETAIL 1

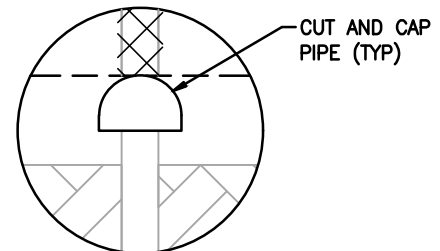

DETAIL 2

NOTES:

1. COMBINATION LINES SHALL BE CUT AND CAPPED AT THE BRANCH POINT (TYPICALLY IN THE WATER METER PIT) AND IRRIGATION BRANCH VALVE SHALL BE REMOVED.
2. IRRIGATION LINES THAT ARE BRANCHED INSIDE A STRUCTURE SHALL BE CUT AND CAPPED AT THE BRANCH POINT AND IRRIGATION BRANCH VALVE SHALL BE REMOVED, IF PRESENT.
3. DEDICATED IRRIGATION LINES SHALL BE CUT AND CAPPED AT THE BACKFLOW DEVICE.
4. ALL OTHER IRRIGATION CUT AND CAP SCENARIOS WILL BE EVALUATED ON A CASE BY CASE BASIS.
5. IN ALL CASES, THE BACKFLOW DEVICE AND IRRIGATION BRANCH VALVE (WHEN APPLICABLE) SHALL BE REMOVED.

CITIZENS WESTFIELD
STANDARD PRACTICE

T.WF1

REVISION DATE: 01/12/2022

ISSUE DATE: 1/1/2015

STANDARD 3/4" WATER METER AND PIT DETAILS
(FOR RESIDENTIAL)

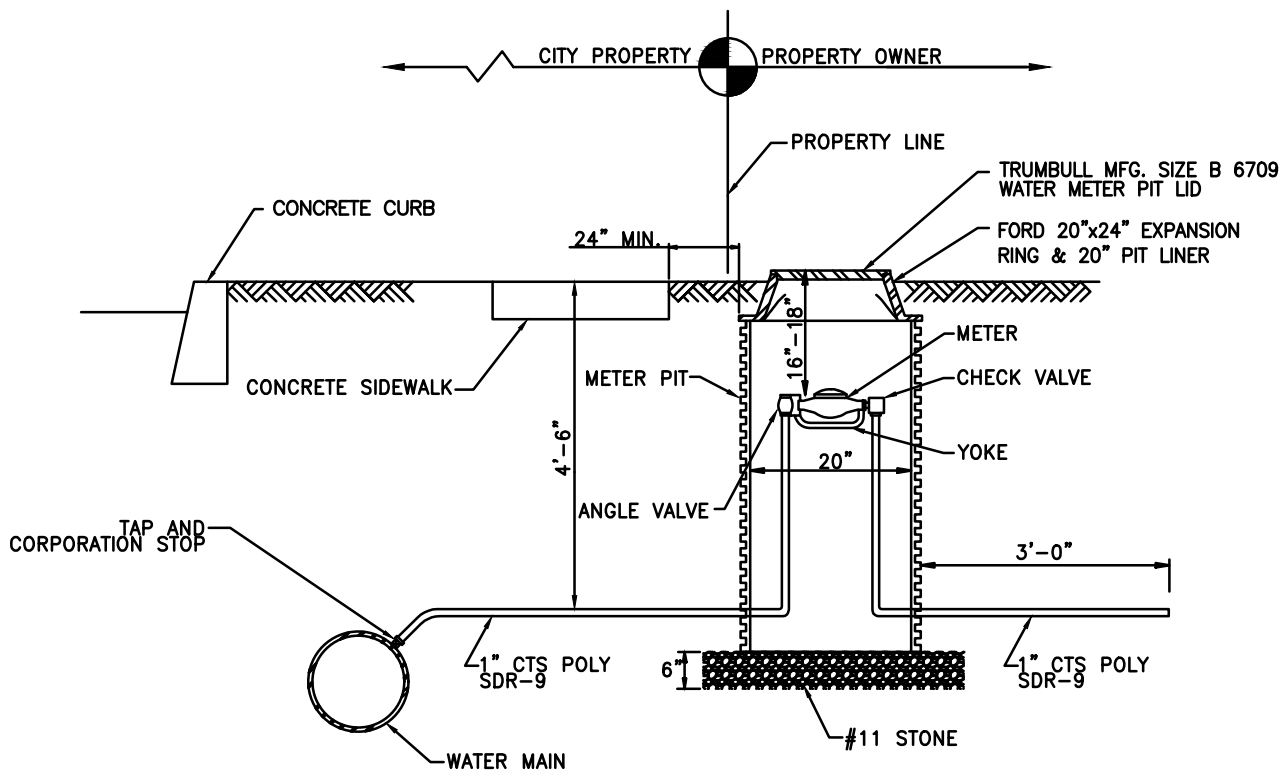

NOTE:

1. CONTRACTOR SHALL FURNISH AND INSTALL ALL NECESSARY MATERIALS TO PROVIDE A NEW WATER SERVICE METER PIT (EXCEPT FOR THE WATER METER) AS SHOWN IN THIS DETAIL.
2. SEE STANDARD PRACTICE DRAWING 'Z' - POLYETHYLENE SERVICE LINE METER SUPPORT (SINGLE METER SET) FOR METER SUPPORT INFORMATION

| ITEMS | FORD PART NUMBERS* |
|-------------|--------------------|
| YOKE | Y502 |
| ANGLE VALVE | AV94-324W-G-NL |
| CHECK VALVE | HA94-324-G-NL |

* OR APPROVED EQUAL

CITIZENS WESTFIELD
STANDARD PRACTICE

T.WF3

REVISION DATE: 01/12/2022

ISSUE DATE: 1/1/2015

1" WATER METER AND PIT DETAILS

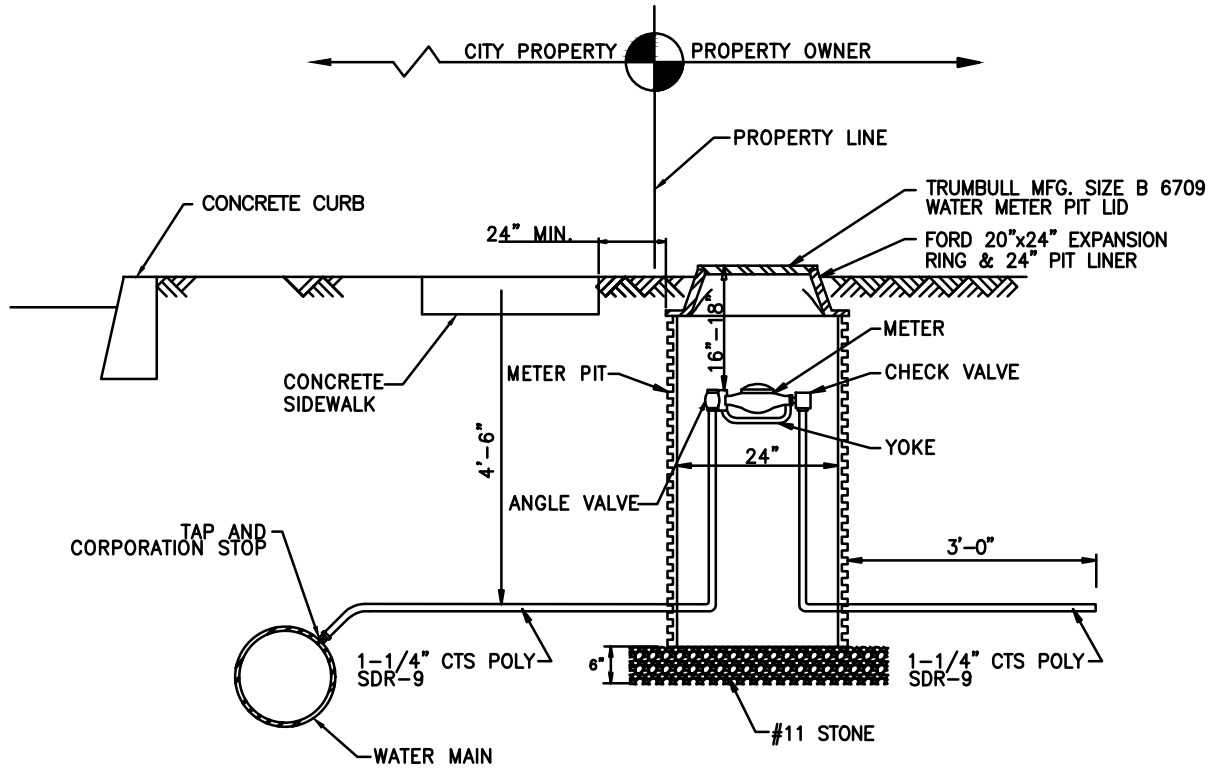

NOTE:

1. CONTRACTOR SHALL FURNISH AND INSTALL ALL NECESSARY MATERIALS TO PROVIDE A NEW WATER SERVICE METER PIT (EXCEPT FOR THE WATER METER) AS SHOWN IN THIS DETAIL.
2. SEE STANDARD PRACTICE DRAWING 'Z' - POLYETHYLENE SERVICE LINE METER SUPPORT (SINGLE METER SET) FOR METER SUPPORT INFORMATION.

| ITEMS | FORD PART NUMBERS* |
|-------------|--------------------|
| YOKE | Y504 |
| ANGLE VALVE | AV94-445W-G-NL |
| CHECK VALVE | HA94-445-AWT-G-NL |

* OR APPROVED EQUAL

IRRIGATION SYSTEM CONNECTION DETAIL
(RESIDENTIAL)

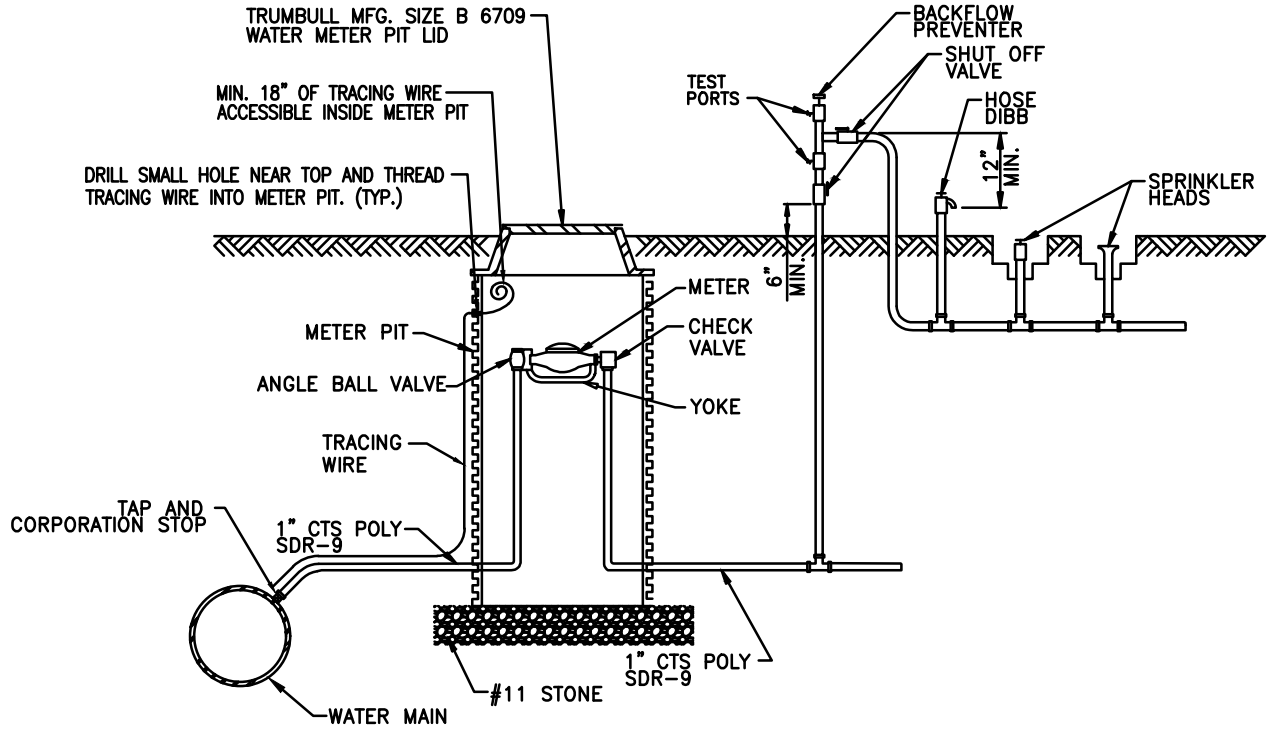

CITIZENS WESTFIELD
STANDARD PRACTICE

T.WF6

REVISION DATE: 11/6/2018

ISSUE DATE: 1/1/2015

STANDARD FIRE SERVICE
AND METER VAULT

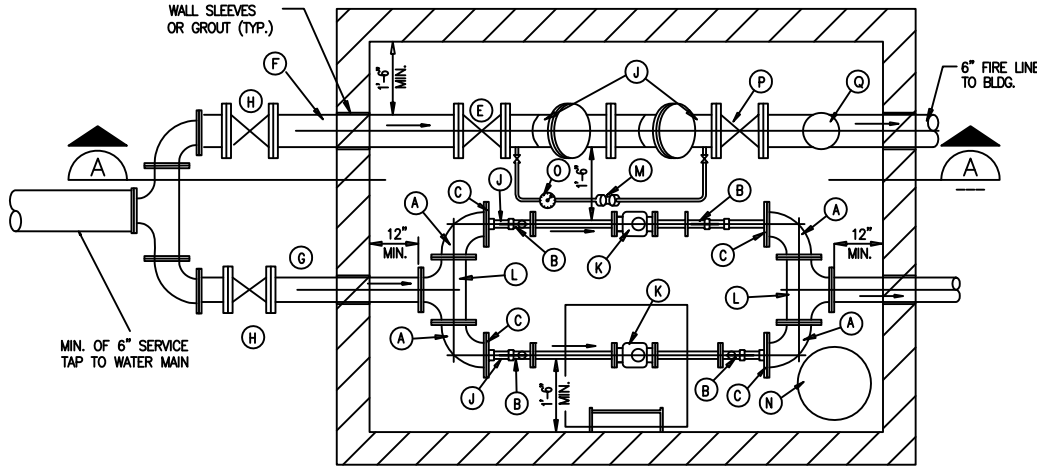

PLAN

SCALE: " = 1'-0"

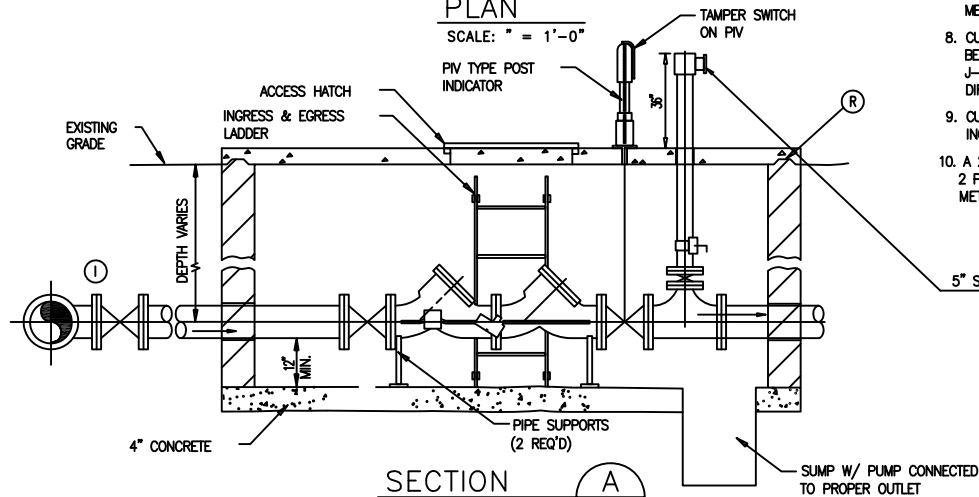

SECTION

SCALE: " = 1'-0"

LEGEND

- | | |
|--|--|
| (A) 90° FLANGED BEND | (H) MECHANICAL JOINT GATE VALVE & BOX |
| (B) BALL VALVE W/ FLANGED END | (I) TAPPING SLEEVE W/ TAPPING VALVE & BOX |
| (C) REDUCING FLANGE | (J) LOK-PAK |
| (D) DOUBLE DETECTOR CHECK VALVE ASSEMBLY | (K) TURBINE METER-FLANGED BOTH ENDS (BY UTILITY) |
| (E) FLANGED OS & Y VALVE | (L) FLANGED TEE |
| (F) FIRE LINE | (M) DOUBLE CHECK VALVE |
| (G) DOMESTIC SERVICE | (N) SUMP WITH PUMP |
| | (O) 3/4"x5/8" METER |
| | (P) POST INDICATOR VALVE |
| | (Q) FIRE DEPARTMENT CONNECTION |
| | (R) O-RING GASKETED JOINT W/ LAYERS OF KENTSEAL MASTIC |

NOTES:

- CUSTOMER SHALL CONSTRUCT METER VAULT
- CONSTRUCTION MATERIALS: CONCRETE, 8"x8"x16" CONCRETE BLOCKS AND MORTAR, OR PRECAST/CAST-IN-PLACE AS DIRECTED BY WATER COMPANY.
- INSIDE DIMENSIONS PER DRAWING NOTES. VAULT TOP BE SET LENGTHWISE WITH SERVICE.
- TOP OF VAULT TO BE CONCRETE, AT LEAST 4" THICK WITH REINFORCING. WHEN VAULT IS CONSTRUCTED IN PAVED AREAS, PAVEMENT IS TO BE LEVEL WITH TOP OF VAULT, AND THE TOP REINFORCED AS REQUIRED TO SUPPORT TRAFFIC LOADS. WHEN VAULT IS CONSTRUCTED IN GRASS PLOT, TOP OF VAULT SHALL CORRESPOND WITH FINISHED GRADE LEVEL OF SURROUNDING AREA.
- BOTTOM OF VAULT TO BE MINIMUM OF 4" CONCRETE AS DIRECTED BY WATER COMPANY, WITH MINIMUM CLEARANCE OF 12" BELOW BOTTOM OF FIRE/SERVICE LINE.
- CUSTOMER SHALL FURNISH 2" BALL VALVES ON OUTLET SIDE OF THE 2" METER SETTING.
- CUSTOMER SHALL FURNISH DOUBLE DETECTOR CHECK VALVE AS APPROVED BY THE INDIANA DEPARTMENT OF ENVIRONMENTAL MANAGEMENT, WITH RESILIENT SEAL GATE VALVE ON OUTLET SIDE OF CHECK VALVE. METER IS FURNISHED BY WATER COMPANY.
- CUSTOMER SHALL FURNISH VAULT FRAME AND LID TO BE INSTALLED IN TOP OF VAULT BY CUSTOMER (BILCO J-24L OR 30"x30" ALUMINUM FOM) WITH HOLES PER THE DIRECTION OF WPMO.
- CUSTOMER SHALL FURNISH A LADDER IN PIT FOR INGRESS AND EGRESS, AS PER OSHA REQUIREMENTS.
- A 2" TEST PLUG SHALL BE INSTALLED AT LEAST 2 PIPE DIAMETERS DOWNSTREAM OF 2" OR LARGER METERS.

5" STORZ CONNECTION FOR HOSE CONNECTION

DUAL METER CONNECTION
WITH DUAL RPZ

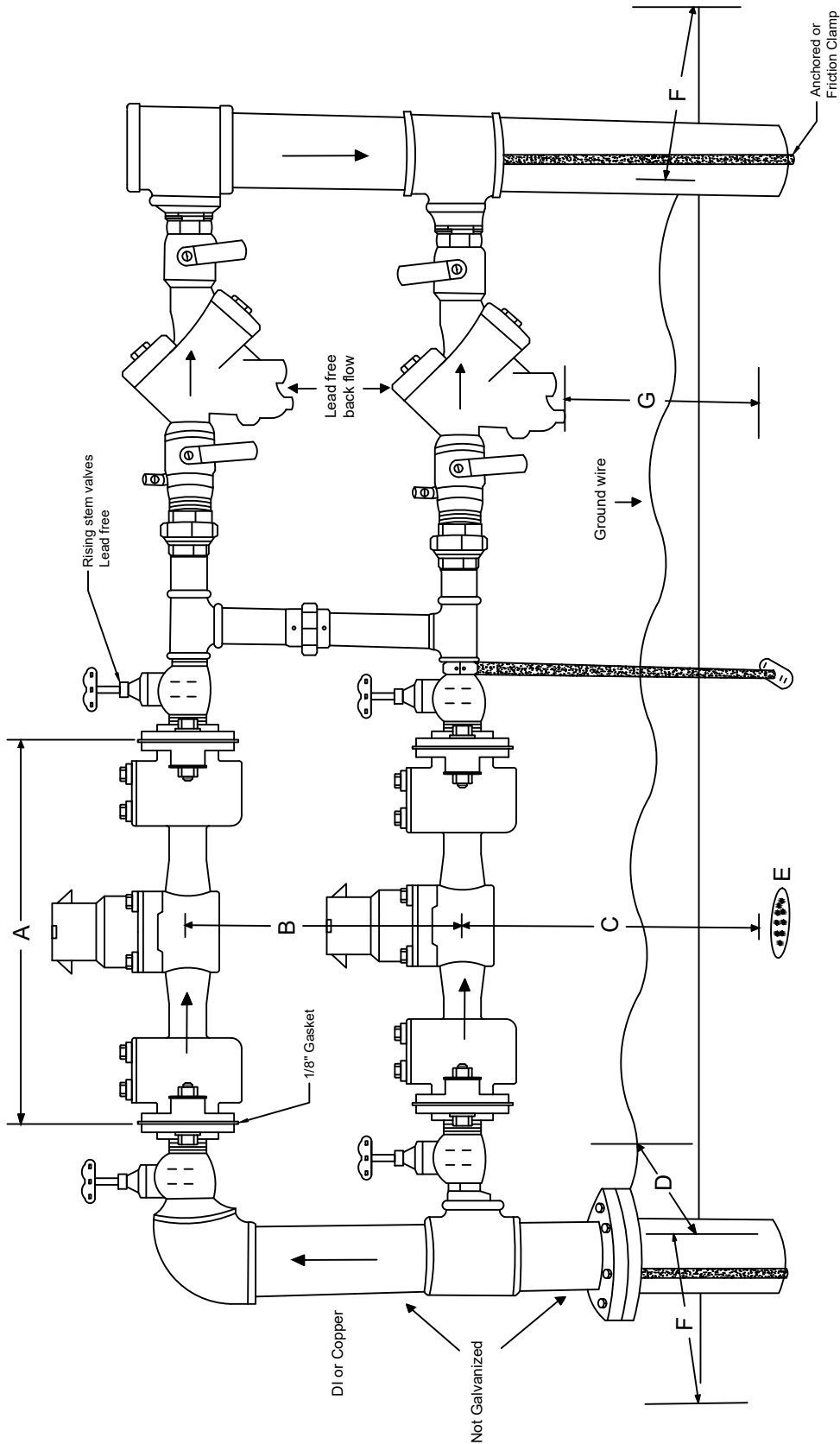

| | |
|---|--|
| A | 2" - 17 3/8" 1 1/2" - 13 3/8" FLANGE TO FLANGE |
| B | 18" |
| C | 18" |
| D | 8" TO 24" |
| E | DRAIN |
| F | MIN. 2' CLEARANCE |
| G | MINIMUM 12" |

NOTE: CEG responsible for meter, gasket, and bolt kit installation
Contractor responsible for all other structures
All rising stem valves are to be lead free

CITIZENS WATER STANDARD PRACTICE

U

REVISION DATE: 10/03/2019

ISSUE DATE: 12/31/2019

MINIMUM REQUIREMENTS FOR WATER STOP INSTALLATION

| |
|--|
| <p>WATER STOP WILL BE FUSED INLINE INTO P.E. PIPE.</p> <p>CONCRETE <u>WILL NOT</u> BE CLOSER THAN 3 FEET AND <u>NO FURTHER</u> THAN 8 FEET TO THE END OF PIPE THAT TRANSITIONS TO THE MECHANICAL JOINT OR PUSH ON JOINT PIPE.</p> <p>CONCRETE IS TO BE POURED OVER THE ANCHOR RING IN A MANNER TO KEY INTO UNDISTURBED SOIL <u>NO LESS</u> THAN 18 INCHES BELOW BOTTOM OF DITCH AND WILL EXTEND A MINIMUM OF 6" BEYOND THE WIDTH OF THE DITCH ON EACH SIDE.</p> <p>WATER STOPS ARE REQUIRED WHEN THERE IS A TRANSITION TO DISSIMILAR MATERIALS REGARDLESS OF LENGTH OF POLY MATERIAL.</p> <p>CONCRETE SHOULD EXTEND <u>NO LESS</u> THAN 12 INCHES TO EACH SIDE AND ABOVE THE PIPE.</p> <p>POURED IN PLACE CONCRETE SHALL HAVE A 28 DAY STRENGTH OF 3,000 P.S.I., 2 IN. TO 4 IN. SLUMP AND INCLUDE WIRE MESH FOR REINFORCEMENT.</p> |
| <p>1 1/2 IN. TO 2 IN. P.E. PIPE MINIMUM ONE 80 LB. BAG OF QUICK SET CONCRETE AROUND ANCHOR RING.</p> |
| <p>3 TO 6 IN. P.E. PIPE MINIMUM 1/2 YARD CONCRETE INSTALLED AROUND ANCHOR RING OF WATER STOP.</p> |
| <p>8 TO 12 IN. P.E. PIPE MINIMUM 1 YARD OF CONCRETE INSTALLED AROUND ANCHOR RING OF WATER STOP.</p> |
| <p>16 TO 20 IN. P.E. PIPE MINIMUM 2 YARDS OF CONCRETE INSTALLED AROUND ANCHOR RING OF WATER STOP.</p> |
| <p>24 TO 30 IN. P.E. PIPE MINIMUM 3 YARDS OF CONCRETE INSTALLED AROUND ANCHOR RING OF WATER STOP.</p> |
| <p>36 IN. P.E. PIPE MINIMUM 4 FOUR YARDS OF CONCRETE INSTALLED AROUND ANCHOR RING OF WATER STOP.</p> |

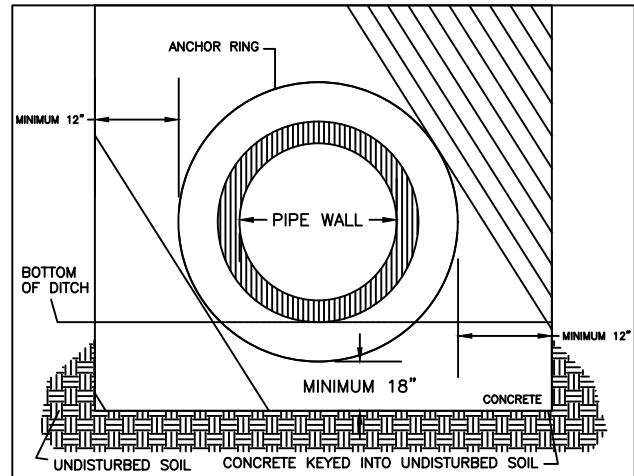

FRONT VIEW (END)

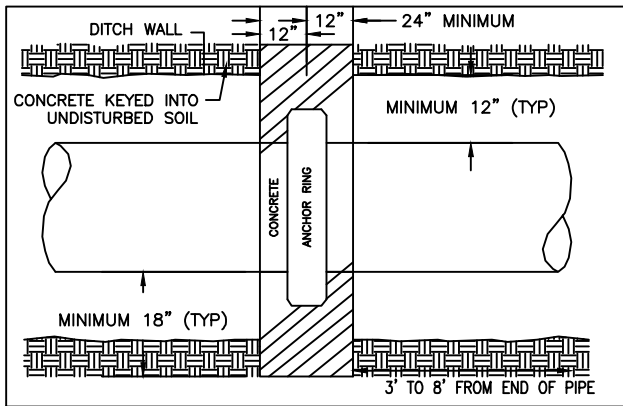

TOP VIEW

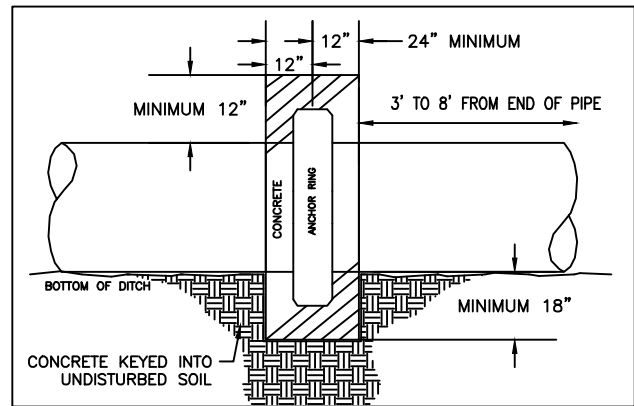

SIDE VIEW (PROFILE)

NOTE:

THIS WATER STOP SERVES TO RESTRAIN AN ANCHOR AGAINST THERMAL EXPANSION AND CONTRACTION. IT IS DESIGNED TO HOLD THE PIPE IN PLACE BY TRANSFERRING THE THERMAL FORCE FROM THE PIPE TO THE SOIL VIA A LARGE AREA OF REINFORCED CONCRETE. CONTRACTOR/DEVELOPER SHALL CONFIRM THE SOIL BEARING LOAD AREA, AS WELL AS THE THICKNESS AND STRENGTH OF THE CONCRETE ARE SUFFICIENT PER THE MINIMUM REQUIREMENTS ABOVE.

FLEXIBLE RESTRAINT SADDLES

Electrofusion Fittings: Flex Restraint

Size Range: Works on solid wall pipe 6" IPS & larger

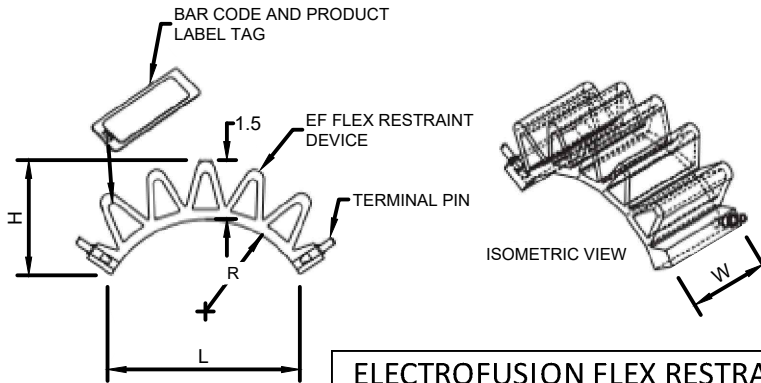
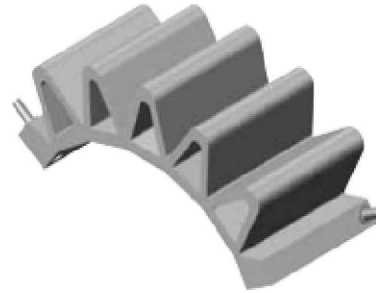

| ELECTROFUSION FLEX RESTRAINT DIMENSIONS | | | |
|---|------|------|------|
| Nominal Base Size | H | W | L |
| 6" - 63" | 2.91 | 2.56 | 4.92 |

| (PE3408/PE4710) ELECTROFUSION FLEX RESTRAINTS | | | | | | | |
|---|------------------|--------------------|----------|------------|-------------|-----------|------|
| Main Size | Axial Resistance | Description | Pin Type | Clamp Type | Part Number | Pack Qty. | Wt. |
| 6"-63" | 9,000 lbs. | Flexible Restraint | 4.7 S | N | 10004637 | 40 | 0.42 |

Flexible Restraint Saddles

60° Temperature Change

| DIPS D _{nom} (in") | DR 9 Number of Restraints Needed (Each Side of Tap) | DR 11 Number of Restraints Needed (Each Side of Tap) |
|-----------------------------------|---|--|
| 8" | 4 | 3 |
| 10" | 6 | 5 |
| 12" | 8 | 7 |
| 14" | 10 | 9 |
| 16" | 13 | 11 |
| 18" | 16 | 14 |
| 20" | 20 | 17 |
| 24" | 28 | 24 |

*The number of restraints recommended for each category are based upon a 60°F temperature change with full pressurization

*A safety factor of 2 was included to account for Poisson's ratio contraction force and providing reserve capacity.

*Restraint saddles in multiple rows are to be offset with rows being a minimum of 1" apart.

CITIZENS WATER
STANDARD PRACTICE

Y.1

REVISION DATE: 10/03/2019

ISSUE DATE: 12/31/2019

4' X 8' X 7' METER VAULT FOR
1 1/2" DOMESTIC METERS

NOTE: OTHER PIPING CONFIGURATIONS
MUST BE APPROVED BY THE UTILITY.

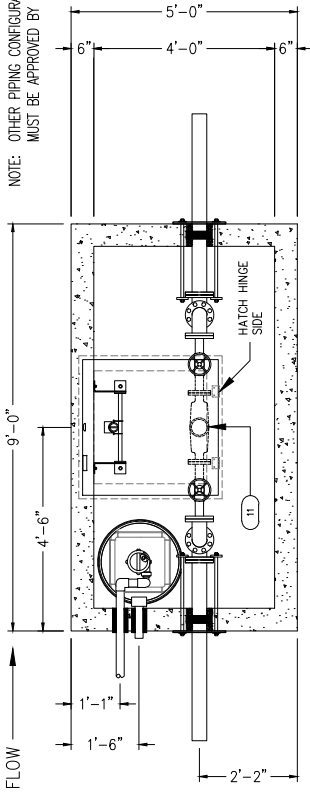

1 PLAN VIEW
1" = 3'-0"

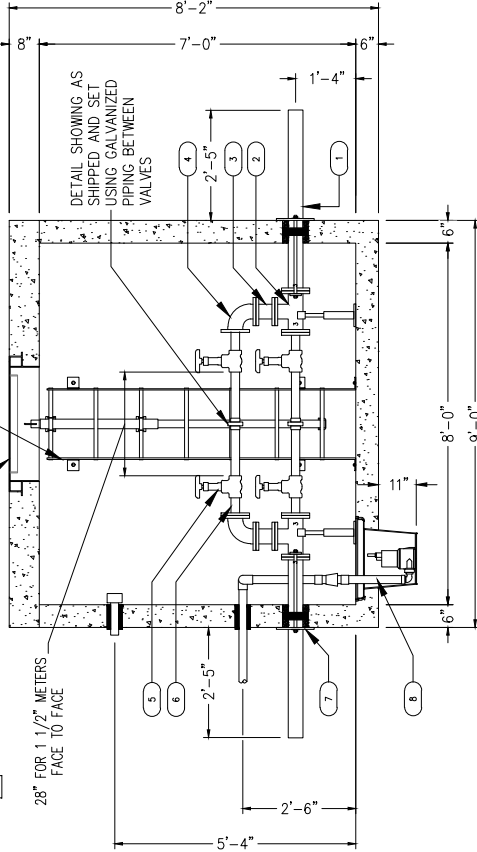

2 SECTION VIEW
1" = 3'-0"

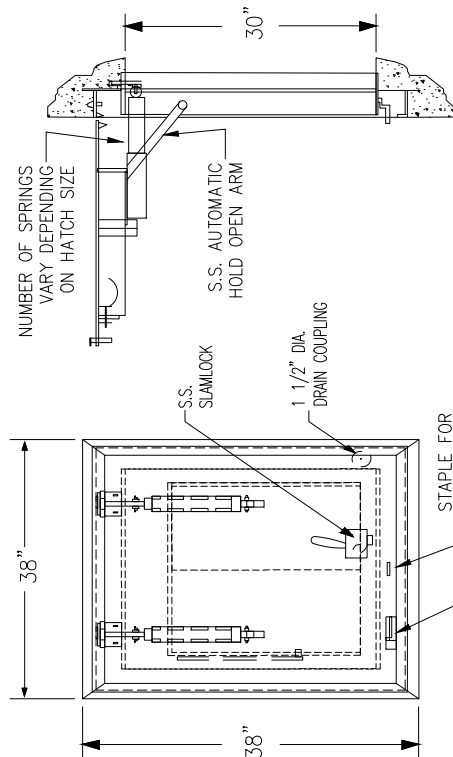

PLAN VIEW
1 1/2" DIA. DRAIN COUPLING
S.S. SLAMLOCK
S.S. AUTOMATIC HOLD OPEN ARM
STAPLE FOR PADLOCK
FLUSH DROP HANDLE

NOTES:
WEIGHT: 79 LBS. (APPROX. HATCH BASE WEIGHT W/O OPTIONS)
1: SKIRT (4" SLAB)
2: CUSTOM LETTERING (CITIZENS ENERGY GROUP)
3: DEBRIS GASKET
1/4" THICK FLOOR PLATE

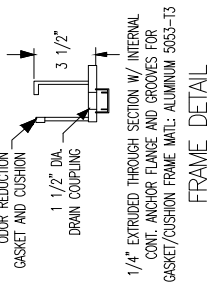

SECTION VIEW SIDE
FRAME DETAIL
ODOR REDUCTION GASKET AND CUSHION
1 1/2" DIA. DRAIN COUPLING
1/4" EXTRUDED THROUGH SECTION W/ INTERNAL CONT. ANCHOR FLANGE AND GROOVES FOR GASKET/CUSHION FRAME MAT'L: ALUMINUM 5053-13

NOTES:
1- MATERIAL ALUMINUM
2- LOADING: 300 LBS. PER SQ. FT.
3- 316 STAINLESS STEEL BOLT HINGES AND HOLD OPEN ARM
4- AREA OF FRAME IN CONTACT WITH CONCRETE TO BE PAINTED WITH BITUMINOUS COATING.

SECTION VIEW FRONT

TPS 30" x 30"
CLEAR OPENING: 29" x 30"

| ITEM QTY. | DESCRIPTION |
|-----------|---|
| 1 | 2 3" x 48" LONG D.I. PIPE, FLG. x P.E. |
| 2 | 2 3" x 3" TEE, FLANGED, D.I., SET ON 100% STAINLESS STEEL PIPE SUPPORT |
| 3 | 2 3" x 5" LONG SPOOL, FLG. TO FLG. |
| 4 | 2 3" DIA. ELBOW, FLANGED, D.I. |
| 5 | 4 1 1/2" NPT BRASS GATE VALVE - RISING STEM - LEAD FREE - TO BE INSTALLED AT 45° ANGLE |
| 6 | 4 1 1/2" x 4" BRASS NIPPLE |
| 7 | 2 CUSTOM STEEL RESTRAINING PLATE, ASPHALTIC PRIMER COATED |
| 8 | 4 3/4" SS ALL THREAD, NUTS, LOCK AND FLAT WASHERS |
| 9 | 4 DUC LUGS |
| 10 | 2 LINK SEAL W/ GROUT EACH SIDE |
| 11 | 1 SUMP PIT W/ GRATE, HDPE BY POLYLOK |
| 12 | 1 SUMP PUMP ASSEMBLY W/ 1/3 HP, 115 VOLT, 1 PH LITTLE GIANT AUTOMATIC PUMP, CONTINUOUS DUTY, OR APPROVED EQUIVALENT |
| 13 | 1 2" SCH 40 PVC "SILENT" CHECK VALVE W/ UNIONS FOR SUMP LINE |
| 14 | 1 2" SUMP DISCHARGE IN CAST-A-SEAL BOOT THROUGH WALL |
| 15 | 1 6"-10" ALUMINUM LADDER W/ (4) WALL MOUNTS, (2) FLOOR MOUNTS |
| 16 | 1 ALUMINUM LADDER UP SAFETY DEVICE, POST TYPE |
| 17 | 6 3/8" STAINLESS ANCHOR BOLT |
| 18 | 6 3/8" STAINLESS WASHER |
| 19 | 6 3/8" STAINLESS NUT |
| 20 | 1 30" x 30" ALUM. HATCH, SPRING ASSIST. USF TPS 3030 |
| 21 | 2 FUTURE 1 1/2" METERS - PROVIDED AND INSTALLED BY CITIZENS ENERGY GROUP |
| 22 | 4 FUTURE 1 1/2" BRASS LOC-PAK COUPLER - METER FLANGE x LOC-PAK |
| 23 | 4 FUTURE 1 1/2" BRASS NIPPLE - 6 1/2" LONG - MIP x BALD |

NOTES:
A) VAULT TO BE SEALED AT JOBSITE W/ 2 1/4" x 3/4" BUTYL SEALANT.
B) SUMP PUMP REQUIRES A 20 AMP 120 VOLT, SINGLE PHASE CIRCUIT, PROVIDED BY OTHERS.
C) TO PREVENT EXCESSIVE CYCLING OF PUMP, A CHECK VALVE W/ UNIONS MUST BE INSTALLED AND SUMP DISCHARGE LINE ROUTED AWAY FROM VAULT TO NEAREST DRAIN.
D) TO PREVENT FLOTATION OF STRUCTURE, SUMP PIT IS NOT WATER TIGHT.
E) ELECTRICAL MUST BE HARD WIRED WITH G.F.I. AND MUST BE IN ACCORDANCE WITH LOCAL JURISDICTION'S ELECTRICAL CODE
F) ALL VALVES AND BACKFLOW DEVICES MUST BE LEAD FREE.
G) VAULT MUST BE BEDDED IN #8 STONE FOR PROPER DRAINAGE.

STANDARDS OF DESIGN:
A) 6" SIDEWALL AND FLOOR THICKNESS, #4 & #5 REBAR-NO WIRE MESH TO BE USED.
B) 8" TOP SLAB THICKNESS - #5 @ 12" O.C. E.W.
C) CONCRETE MINIMUM COMPRESSIVE STRENGTH F_c = 5000 PSI @ 28 DAYS.
D) REINFORCING STEEL: ASTM A615, F_y = 60,000 PSI.
E) DESIGN SPECIFICATIONS: ACI 318.
F) DESIGN LOADING: NON-TRAFFIC BEARING.
G) INTERIOR DIMENSIONS - 4'-0" WIDE x 8'-0" LONG x 7'-0" TALL.
H) 12" MIN. FROM END WALLS TO FIRST JOINT - 18" FROM SIDE WALLS TO C. OF PIPING, FITTINGS.
I) 100% STAINLESS STEEL HARDWARE - NUTS, BOLTS, WASHERS, PIPE STANDS, ANCHORS, ETC.
J) CAST AS BASE WITH FULL HEIGHT WALLS.

DESIGN SPECIFICS:
STRUCTURE WEIGHTS:
A) NO GROUND WATER3,875 LBS.
B) NO EARTH COVER
BOTTOM SLAB W/ WALLS.....17,025 LBS.
TOTAL CONCRETE WEIGHT.....20,900 LBS.

CITIZENS WATER
STANDARD PRACTICE

Y.2

REVISION DATE: 10/03/2019

ISSUE DATE: 12/31/2019

4' X 8' X 7' METER VAULT FOR
2" DOMESTIC METERS

NOTE: OTHER PIPING CONFIGURATIONS
MUST BE APPROVED BY THE UTILITY.

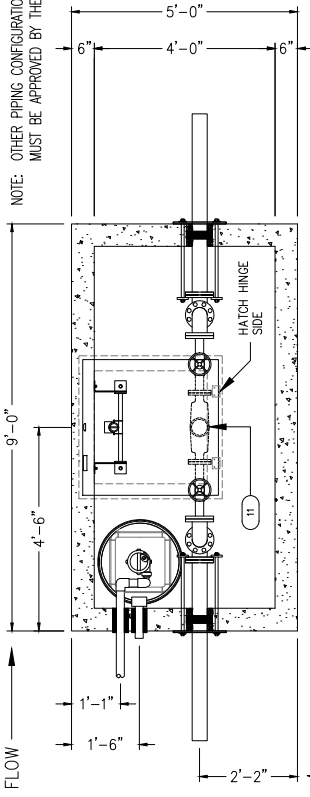

1 PLAN VIEW
1" = 3'-0"

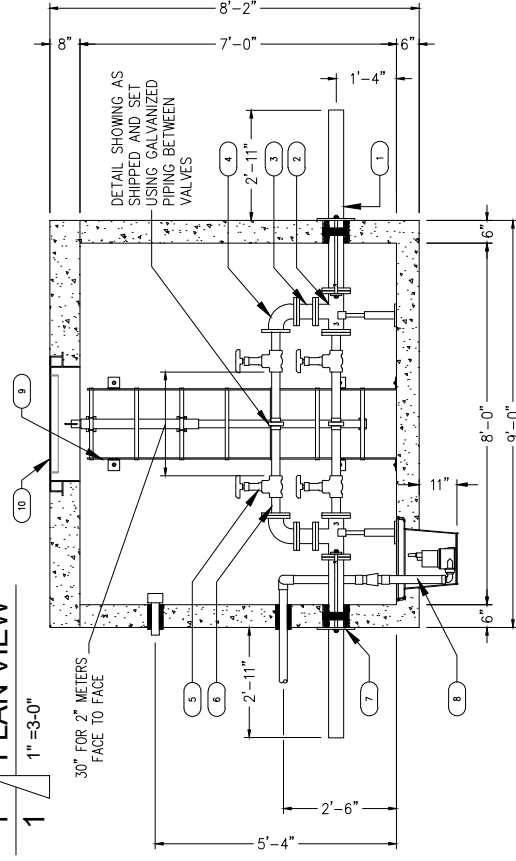

2 SECTION VIEW
1" = 3'-0"

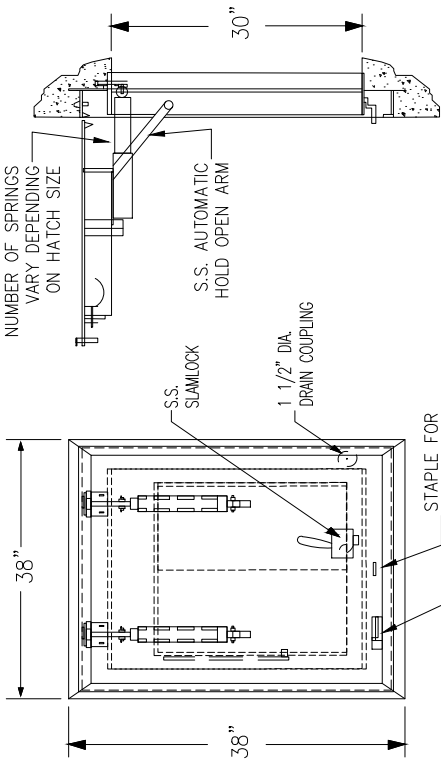

SECTION VIEW SIDE

- NOTES:
WEIGHT: 79 LBS. (APPROX. HATCH BASE WEIGHT W/O OPTIONS)
1: SKIRT (4" SLAB)
2: CUSTOM LETTERING (CITIZENS ENERGY GROUP)
3: DEBRIS GASKET
1/4" THICK FLOOR PLATE

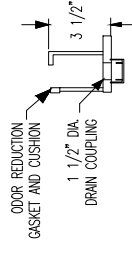

SECTION VIEW FRONT

TPS 30" x 30"
CLEAR OPENING: 29" x 30"

| ITEM QTY. | DESCRIPTION |
|-----------|--|
| 1 | 2 4" x 48" LONG D.I. PIPE, FLG x P.E. |
| 2 | 2 4" x 4" TEE, FLANGED, D.I., SET ON 100% STAINLESS STEEL PIPE SUPPORT |
| 3 | 2 5" x 5" LONG SPOOL, FLG. TO FLG. |
| 4 | 2 4" DIA. ELBOW, FLANGED, D.I. |
| 5 | 4 2" NPT BRASS GATE VALVE - RISING STEM - LEAD FREE - TO BE INSTALLED AT 45° ANGLE |
| 6 | 4 2" x 4" BRASS NIPPLE |
| 7 | 4 4" DIA. x 2" BLIND TAP FLANGE |
| 8 | 2 CUSTOM STEEL RESTRAINING PLATE, ASPHALTIC PRIMER COATED |
| 9 | 4 3/4" SS ALL THREAD, NUTS, LOCK AND FLAT WASHERS |
| 10 | 4 DUC LUGS |
| 11 | 2 LINK SEAL W/ GROUT EACH SIDE |
| 12 | 1 SUMP PIT W/ GRATE, HDPE BY POLYLOK |
| 13 | 1 2" SCH 40 PVC "SILENT" CHECK VALVE W/ UNIONS FOR SUMP LINE |
| 14 | 1 2" SUMP DISCHARGE IN CAST-A-SEAL BOOT THROUGH WALL |
| 15 | 1 6"-10" ALUMINUM LADDER W/ (4) WALL MOUNTS; (2) FLOOR MOUNTS |
| 16 | 1 ALUMINUM LADDER UP SAFETY DEVICE, POST TYPE |
| 17 | 6 3/8" STAINLESS ANCHOR BOLT |
| 18 | 6 3/8" STAINLESS WASHER |
| 19 | 6 3/8" STAINLESS NUT |
| 20 | 10 1 3/8" x 30" ALUM. HATCH, SPRING ASSIST, USF TPS 3030 |
| 21 | 11 2" FUTURE 2" METERS PROVIDED AND INSTALLED BY CITIZENS ENERGY GROUP |
| 22 | 4 FUTURE 2" BRASS LOC-PAK COUPLER - METER FLANGE x LOC-PAK |
| 23 | 4 FUTURE 2" BRASS NIPPLE - 6 1/2" LONG - MIP x BALD |

- NOTES:
- A) VAULT TO BE SEALED AT JOBSITE W/ 2 1/4" x 3/4" BUTYL SEALANT.
 - B) SUMP PUMP REQUIRES A 20 AMP 120 VOLT, SINGLE PHASE CIRCUIT, PROVIDED BY OTHERS.
 - C) TO PREVENT EXCESSIVE CYCLING OF PUMP, A CHECK VALVE W/ UNIONS MUST BE INSTALLED AND SUMP DISCHARGE LINE ROUTED AWAY FROM VAULT TO NEAREST DRAIN.
 - D) TO PREVENT FLOTATION OF STRUCTURE, SUMP PIT IS NOT WATER TIGHT.
 - E) ELECTRICAL MUST BE HARD WIRE WITH G.F.I. AND MUST BE IN ACCORDANCE WITH LOCAL JURISDICTION'S ELECTRICAL CODE.
 - F) ALL VALVES AND BACKFLOW DEVICES MUST BE LEAD FREE.
 - G) VAULT MUST BE BEDDED IN #6 STONE FOR PROPER DRAINAGE.
- STANDARDS OF DESIGN:
- A) 6" SIDEWALL AND FLOOR THICKNESS #4 & #5 REBAR-NO WIRE MESH TO BE USED.
 - B) 8" TOP SLAB THICKNESS - #5 @ 12" O.C. E.W.
 - C) CONCRETE MINIMUM COMPRESSIVE STRENGTH F_c = 5000 PSI @ 28 DAYS.
 - D) REINFORCING STEEL: ASTM A615, F_y = 60,000 PSI.
 - E) DESIGN SPECIFICATIONS: ACI 318.
 - F) DESIGN LOADING: NON-TRAFFIC BEARING.
 - G) INTERIOR DIMENSIONS - 4'-0" WIDE x 8'-0" LONG x 7'-0" TALL
 - H) 12" MIN. FROM END WALLS TO FIRST JOINT - 18" FROM SIDE WALLS TO C.F. OF PIPING, FITTINGS.
 - I) 100% STAINLESS STEEL HARDWARE - NUTS, BOLTS, WASHERS, PIPE STANDS, ANCHORS, ETC.
 - J) CAST AS BASE WITH FULL HEIGHT WALLS.
- DESIGN SPECIFICS:
- A) NO GROUND WATER
 - B) NO EARTH COVER
- STRUCTURE WEIGHTS:
- TOP SLAB.....3,875 LBS.
 - BOTTOM SLAB W/ WALLS.....17,025 LBS.
 - TOTAL CONCRETE WEIGHT.....20,900 LBS.

CITIZENS WATER STANDARD PRACTICE

Y.3

REVISION DATE: 10/03/2019

ISSUE DATE: 12/31/2019

4' X 8' X 7' VAULT FOR BACKFLOW PREVENTION WITH F.D.C. AND P.I.V.

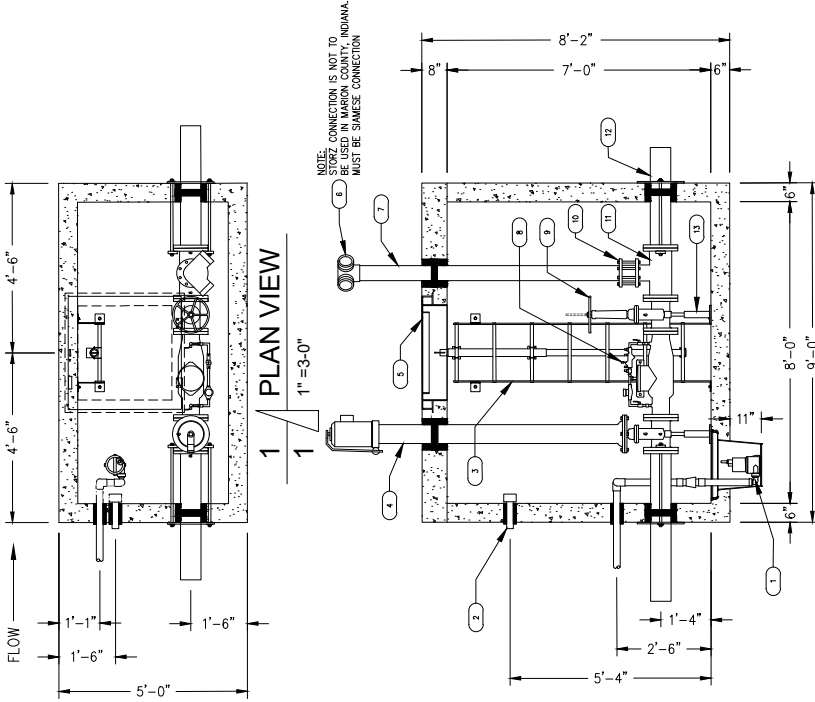

1 PLAN VIEW
1" = 3'-0"

2 SECTION VIEW
1" = 3'-0"

| ITEM QTY. | DESCRIPTION |
|-----------|--|
| 1 | SUMP PIT W/ GRADE, HOPE BY POLYLOK |
| 1 | SUMP PUMP ASSEMBLY w/ 1/3 HP, 115 VOLT, 1 PH LITTLE GRANT AUTOMATIC PUMP, CONTINUOUS OR APPROVED EQUAL |
| 1 | 2" SCH 40 PVC "SILENT" CHECK VALVE w/ UNIONS FOR SUMP LINE |
| 1 | 2" SUMP DISCHARGE IN CAST-A-SEAL BOOT THROUGH WALL |
| 2 | NEMA 4X JUNCTION BOX w/ LIQUID TIE CONNECTORS |
| 1 | 2" SCH 80 PVC CONDUIT, CAST-A-SEAL BOOT THROUGH WALL |
| 1 | 6"-10" ALUMINUM LADDER w/ (4) WALL MOUNTS, (2) FLOOR MOUNTS |
| 1 | ALUMINUM LADDER UP SAFETY DEVICE, POST TYPE |
| 6 | 3/8" STAINLESS ANCHOR BOLT |
| 6 | 3/8" STAINLESS WASHER |
| 6 | 3/8" STAINLESS NUT |
| 4 | PIT TYPE "4" UL FM INDICATOR POST |
| 1 | SUPERVISORY SWITCH |
| 1 | LINK SEAL w/ GROUT EACH SIDE |
| 5 | 1 30" x 30" ALUM. HATCH, SPRING ASSIST, USF TFS 3030 |
| 6 | SHAMESE CONNECTION OR STORZ w/ SWIVEL AND CAP (SEE NOTE) |
| 1 | 4" GALV. STREET 90° ELBOW (FOR STORZ CONNECTION ONLY) |
| 7 | 1 4" x 96" THRD. x FIG. GALV. PIPE |
| 1 | LINK SEAL w/ GROUT EACH SIDE |
| 8 | 1 4" x 6" OR 8" DOUBLE CHECK DETECTOR ASSEMBLY |
| 9 | 2 4" x 6" OR 8" DIA. US & Y VALVE |
| 10 | 1 4" WATER CHECK VALVE w/ 1/2" DRIP |
| 11 | 1 6" x 4" TEE |
| 12 | 2 4" x 6" OR 8" DIA. x VARIES D.I. PIPE |
| 2 | CUSTOM STEEL RESTRAINING PLATE, ASPHALTIC PRIMER COATED |
| 4 | 3/4" SS ALL THREAD, NUTS, LOCK AND FLAT WASHERS |
| 4 | IDUC LUGS |
| 2 | LINK SEAL w/ GROUT EACH SIDE |
| 13 | 2 100# STAINLESS STEEL PIPE SUPPORT |

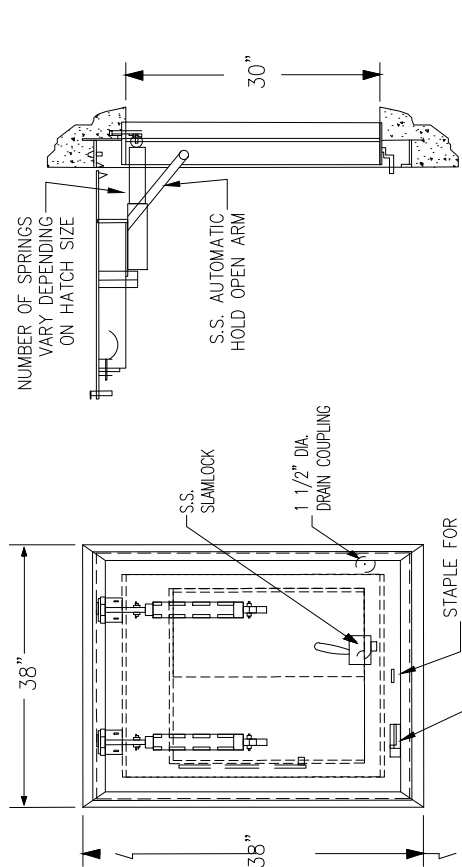

SECTION VIEW SIDE

FRAME DETAIL

NOTES:
 WEIGHT: 79 LBS. (APPROX. HATCH BASE WEIGHT W/O OPTIONS)
 1: SKIRT (4" SLAB)
 2: CUSTOM LETTERING (CITIZENS ENERGY GROUP)
 3: DEBRIS GASKET

NOTES

- 1-WATERIAL ALUMINUM
 - 2-LOADING: 300 LBS. PER SQ. FT.
 - 3-316 STAINLESS STEEL BOLT HINGES AND HOLD OPEN ARM
 - 4-AREA OF FRAME IN CONTACT WITH CONCRETE TO BE PAINTED WITH BITUMINOUS COATING.
- 1/4" EXTRUDED THROUGH SECTION W/ INTERNAL CONT. ANCHOR FLANGE AND GROOVES FOR GASKET/CUSHION FRAME MATL: ALUMINUM 5053-13

SECTION VIEW FRONT

TIPS 30" x 30"
 CLEAR OPENING: 29" x 30"

- NOTES:
- A.) VAULT TO BE SEALED AT JOBSITE w/ 2 1/4" x 3/4" BUTYL SEALANT.
 - B.) SUMP PUMP REQUIRES A 20 AMP 120 VOLT, SINGLE PHASE CIRCUIT, PROVIDED BY OTHERS.
 - C.) TO PREVENT EXCESSIVE CYCLING OF PUMP, A CHECK VALVE w/ UNIONS MUST BE INSTALLED AND SUMP DISCHARGE LINE ROUTED AWAY FROM VAULT TO NEAREST DRAIN.
 - D.) TO PREVENT FLOTATION OF STRUCTURE, SUMP PIT IS NOT WATERTIGHT.
 - E.) ELECTRICAL MUST BE HARD WIRED WITH G.F.I. AND MUST BE IN ACCORDANCE WITH LOCAL JURISDICTION'S ELECTRICAL CODE.
 - F.) ALL VALVES AND BACKFLOW DEVICES MUST BE LEAD FREE.
 - G.) VAULT MUST BE BEDDED IN #8 STONE FOR PROPER DRAINAGE.

STANDARDS OF DESIGN:

- A.) 6" SIDEWALL AND FLOOR THICKNESS #4 & #5 REBAR-NO WIRE MESH TO BE USED.
- B.) 8" TOP SLAB THICKNESS - #5 @ 12" O.C. E.W.
- C.) CONCRETE MINIMUM COMPRESSIVE STRENGTH F_c = 5000 PSI @ 28 DAYS.
- D.) REINFORCING STEEL: ASTM A615, F_y = 60,000 PSI.
- E.) DESIGN SPECIFICATIONS: ACI 318.
- F.) DESIGN SPECIFICATIONS: NON-TRAFFIC BEARING.
- G.) INTERIOR DIMENSIONS - 4'-0" WIDE x 8'-0" LONG x 7'-0" TALL
- H.) 12" MIN. FROM END WALLS TO FIRST JOINT - 18" FROM SIDE WALLS TO C. OF PIPING, FITTINGS.
- I.) 100% STAINLESS STEEL HARDWARE - NUTS, BOLTS, WASHERS, PIPE STANDS, ANCHORS, ETC.
- J.) CAST AS BASE WITH FULL HEIGHT WALLS.

DESIGN SPECIFICS:

- A.) NO GROUND WATER
 - B.) NO EARTH COVER
- STRUCTURE WEIGHTS:
 TOP SLAB.....3,875 LBS.
 BOTTOM SLAB w/ WALLS.....17,025 LBS.
 TOTAL CONCRETE WEIGHT.....20,900 LBS.

CITIZENS WATER STANDARD PRACTICE

Y.4

REVISION DATE: 10/03/2019

ISSUE DATE: 12/31/2019

4' X 8' X 7' VAULT FOR BACKFLOW PREVENTION

NOTE: OTHER PIPING CONFIGURATIONS MUST BE APPROVED BY THE UTILITY.

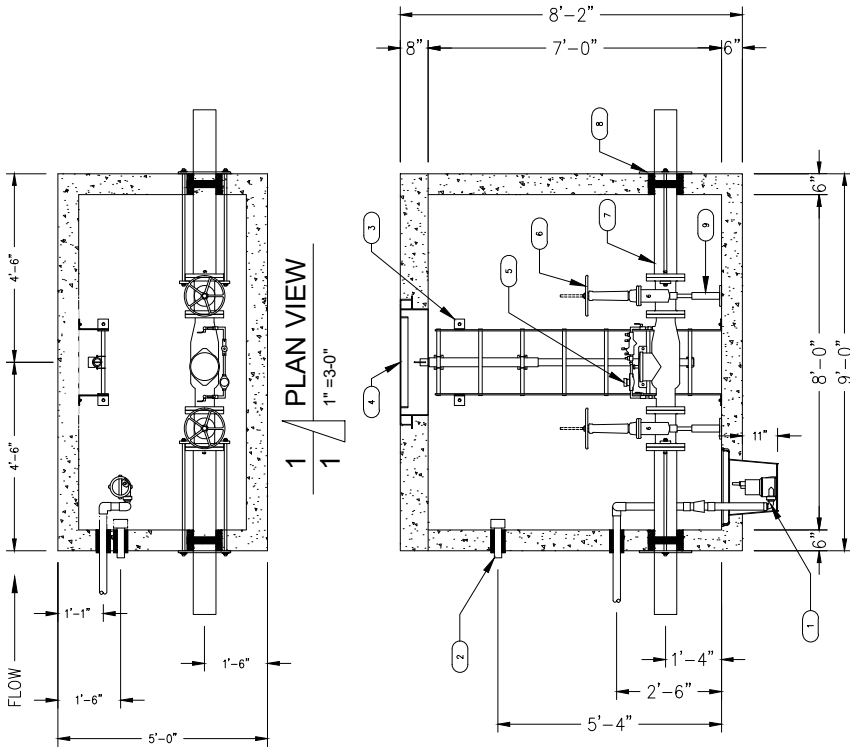

1 PLAN VIEW
1" = 3'-0"

2 SECTION VIEW
1" = 3'-0"

| ITEM | QTY. | PLAN NOTES | DESCRIPTION |
|------|------|------------|---|
| 1 | 1 | | SUMP PIT w/ GRATE, HDPE BY POLYLOK |
| 1 | 1 | | SUMP PUMP ASSEMBLY w/ 1/3 HP, 115 VOLT, 1 PH LITTLE GIANT AUTOMATIC PUMP, CONTINUOUS DUTY OR APPROVED EQUAL |
| 1 | 2" | | SCH 40 PVC "SILENT" CHECK VALVE w/ UNIONS FOR SUMP LINE |
| 1 | 2" | | SUMP DISCHARGE IN CAST-A-SEAL BOOT THROUGH WALL |
| 2 | 1 | | NEMA 4X JUNCTION BOX w/ LIQUID TITE CONNECTORS |
| 3 | 1 | | 2" SCH 80 PVC CONDUIT, CAST-A-SEAL BOOT THROUGH WALL |
| 3 | 1 | | 6"-10" ALUMINUM LADDER w/ (4) WALL MOUNTS, (2) FLOOR MOUNTS |
| 1 | 1 | | ALUMINUM LADDER UP SAFETY DEVICE, POST TYPE |
| 6 | 3/8" | | STAINLESS ANCHOR BOLT |
| 6 | 3/8" | | STAINLESS WASHER |
| 6 | 3/8" | | STAINLESS NUT |
| 4 | 1 | | 30" x 30" ALUM. HATCH, SPRING ASSIST. USF TIPS 3030 |
| 5 | 1 | | 4", 6" OR 8" DOUBLE CHECK DETECTOR ASSEMBLY |
| 6 | 2 | | 4", 6" OR 8" DIA. OS & Y VALVE |
| 7 | 2 | | 4", 6" OR 8" DIA. x VARIES DI. PIPE |
| 8 | 2 | | CUSTOM STEEL RESTRAINING PLATE, ASPHALTIC PRIMER COATED |
| 4 | 3/4" | | SS ALL THREAD, NUTS, LOCK AND FLAT WASHERS |
| 4 | 4 | | DUC LUGS |
| 2 | 1 | | LINK SEAL w/ GROUT EACH SIDE |
| 9 | 2 | | 100% STAINLESS STEEL PIPE SUPPORT |

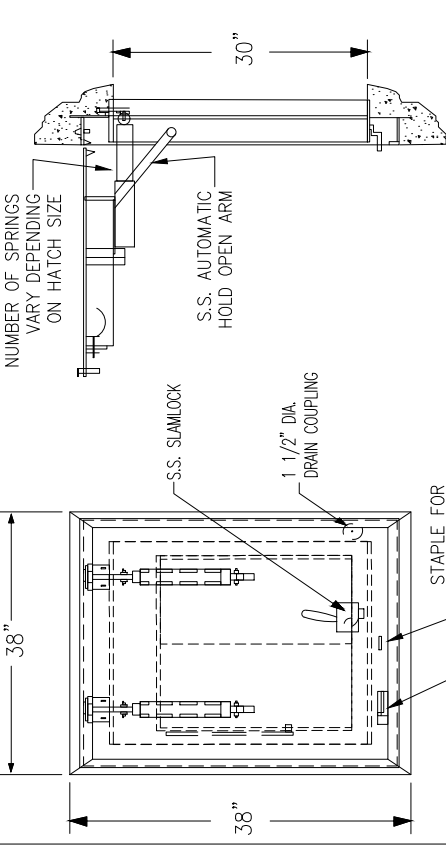

SECTION VIEW SIDE

SECTION VIEW FRONT

NOTES:
 WEIGHT: 79 LBS. (APPROX. HATCH BASE WEIGHT W/O OPTIONS)
 1: SKIRT (4" SLAB)
 2: CUSTOM LETTERING (CITIZENS ENERGY GROUP)
 3: DEBRIS GASKET

NOTES:
 1- MATERIAL ALUMINUM
 2- LOADING: 300 LBS. PER SQ. FT.
 3- 316 STAINLESS STEEL BOLT HINGES AND HOLD OPEN ARM
 4- AREA OF FRAME IN CONTACT WITH CONCRETE TO BE PAINTED WITH BITUMINOUS COATING.

TPS 30" x 30"
 CLEAR OPENING: 29" x 30"

NOTES:
 A.) VAULT TO BE SEALED AT JOBSITE w/ 2 1/4" x 3/4" BUTYL SEALANT.
 B.) SUMP PUMP REQUIRES A 20 AMP 120 VOLT, SINGLE PHASE CIRCUIT, PROVIDED BY OTHERS.
 C.) TO PREVENT EXCESSIVE CYCLING OF PUMP, A CHECK VALVE w/ UNIONS MUST BE INSTALLED AND SUMP DISCHARGE LINE ROUTED AWAY FROM VAULT TO NEAREST DRAIN.
 D.) TO PREVENT FLOATION OF STRUCTURE, SUMP PIT IS NOT WATER TIGHT.
 E.) ELECTRICAL MUST BE HARD WIRED WITH G.F.I. AND MUST BE IN ACCORDANCE WITH LOCAL JURISDICTION'S ELECTRICAL CODE.
 F.) ALL VALVES AND BACKFLOW DEVICES MUST BE LEAD FREE.
 G.) VAULT MUST BE BEDDED IN #8 STONE FOR PROPER DRAINAGE.

STANDARDS OF DESIGN:
 A.) 6" SIDEWALL AND FLOOR THICKNESS #4 & #5 REBAR-NO WIRE MESH TO BE USED.
 B.) 8" TOP SLAB THICKNESS - #5 @ 12" O.C. E-W
 C.) CONCRETE MINIMUM COMPRESSIVE STRENGTH F_c = 5000 PSI @ 28 DAYS.
 D.) REINFORCING STEEL: ASTM A615, F_y = 60,000 PSI.
 E.) DESIGN SPECIFICATIONS: AGI 318.
 F.) DESIGN LOADING: NON-TRAFFIC BEARING.
 G.) INTERIOR DIMENSIONS - 4'-0" WIDE x 8'-0" LONG x 7'-0" TALL.
 H.) 12" MIN. FROM END WALLS TO FIRST JOINT - 18" FROM SIDE WALLS TO C. OF PIPING, FITTINGS, ETC.
 I.) 100% STAINLESS STEEL HARDWARE - NUTS, BOLTS, WASHERS, PIPE STANDS, ANCHORS, ETC.
 J.) CAST AS BASE WITH FULL HEIGHT WALLS.

DESIGN SPECIFICS:
 A.) NO GROUND WATER
 B.) NO EARTH COVER

STRUCTURE WEIGHTS:
 TOP SLAB.....3,875 LBS.
 BOTTOM SLAB w/ WALLS.....17,025 LBS.
 TOTAL CONCRETE WEIGHT.....20,900 LBS.

CITIZENS WATER STANDARD PRACTICE

Y.5

REVISION DATE: 10/03/2019

ISSUE DATE: 12/31/2019

6' X 10' X 7' VAULT FOR 3" DOMESTIC METERS

NOTE: OTHER PIPING CONFIGURATIONS MUST BE APPROVED BY THE UTILITY.

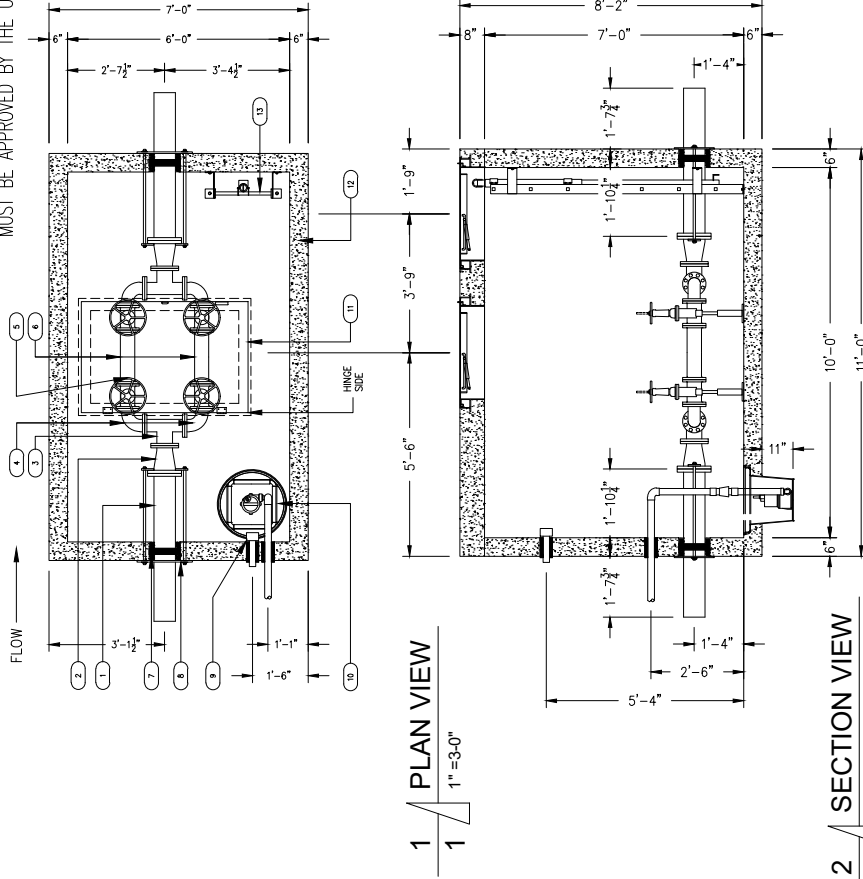

| ITEM | QTY. | DESCRIPTION |
|------|------|---|
| 1 | 2 | 6" x 48" LONG D.I. PIPE, FLG x P.E. |
| 2 | 2 | 6" x 4" REDUCER, FLANGED, D.I. |
| 3 | 2 | 3" x 3" x 4" Tee, FLANGED, D.I. |
| 4 | 4 | 3" DIA. ELBOW, FLANGED, D.I. |
| 5 | 4 | 3" DIA. OS & Y VALVE |
| 6 | 2 | 100% STAINLESS STEEL PIPE SUPPORT UNDER |
| 7 | 2 | 3" x 17 1/2" LONG SUMP, FLG x FLG, DIA. FOR METER "HOLD" ENERGY GROUP, 3" x 17" LONG |
| 8 | 2 | 10" HOLE FILLED w/ NON-SHRINK GROUT |
| 9 | 2 | LINK SEAL FOR 6" D.I. PIPE |
| 10 | 2 | CUSTOM STEEL RESTRAINING PLATE, ASPHALTIC PRIMER COATED |
| 11 | 4 | 3/4" SS ALL THREAD, NUTS, LOCK AND FLAT WASHERS |
| 12 | 4 | DUC LUGS |
| 13 | 1 | NEVA 4X JUNCTION BOX w/ LIQUID TIE CONNECTORS |
| 14 | 1 | 2" SCH 80 PVC CONDUIT, CAST-IN-SEAL BOOT THROUGH WALL |
| 15 | 1 | SUMP PIT w/ GRATE, HOPE BT POLYLOCK |
| 16 | 1 | SUMP PUMP ASSEMBLY w/ 7/3 HP, 115 VOLT, 1 PH LITTLE GIANT AUTOMATIC PUMP, CONTINUOUS DUTY OR APPROVED EQUAL |
| 17 | 1 | 2" SCH 40 PVC "SILENT" CHECK VALVE w/ UNIONS FOR SUMP LINE |
| 18 | 1 | 30" x 48" ALUM. HATCH, SPRING ASSIST, USF TFS 3048 |
| 19 | 1 | 30" x 30" ALUM. HATCH, SPRING ASSIST, USF TFS 3030 |
| 20 | 1 | 6'-10" ALUMINUM LADDER w/ (4) WALL MOUNTS, (2) FLOOR MOUNTS |
| 21 | 1 | ALUMINUM LADDER UP SAFETY DEVICE, POST TYPE |
| 22 | 6 | 3/8" STAINLESS ANCHOR BOLT |
| 23 | 6 | 3/8" STAINLESS WASHER |
| 24 | 6 | 3/8" STAINLESS NUT |

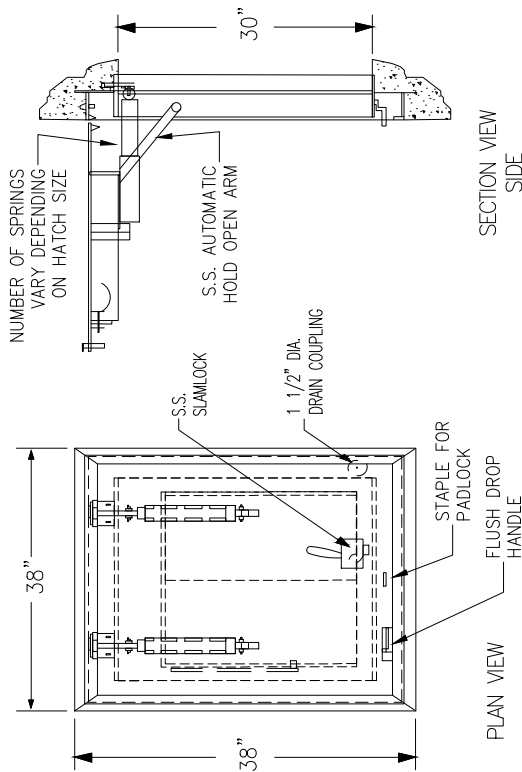

NOTES:
 WEIGHT: 79 LBS. (APPROX. HATCH BASE WEIGHT W/O OPTIONS)
 1: SKIRT (4" SLAB)
 2: CUSTOM LETTERING (CITIZENS ENERGY GROUP)
 3: DEBRIS GASKET

NOTES:
 1-MATERIAL ALUMINUM
 2-LOADING: 300 LBS. PER SQ. FT.
 3-316 STAINLESS STEEL BOLT HINGES AND HOLD OPEN ARM
 4-AREA OF FRAME IN CONTACT WITH CONCRETE TO BE PAINTED WITH BITUMINOUS COATING.

STANDARDS OF DESIGN:
 A.) 6" SIDEWALL AND FLOOR THICKNESS #4 & #5 REBAR-NO WIRE MESH TO BE USED.
 B.) 8" TOP SLAB THICKNESS - #5 @ 12" O.C. E.W.
 C.) CONCRETE MINIMUM COMPRESSIVE STRENGTH F_c = 5000 PSI @ 28 DAYS.
 D.) REINFORCING STEEL: ASTM A615, F_y = 60,000 PSI.
 E.) DESIGN SPECIFICATIONS: ACI 318.
 F.) DESIGN LOADING: NON-TRAFFIC BEARING.
 G.) INTERIOR DIMENSIONS - 4'-0" WIDE x 8'-0" LONG x 7'-0" TALL.
 H.) 12" MIN. FROM END WALLS TO FIRST JOINT - 18" FROM SIDE WALLS TO ϕ OF PIPING, FITTINGS.
 I.) 100% STAINLESS STEEL HARDWARE - NUTS, BOLTS, WASHERS, PIPE STANDS, ANCHORS, ETC.
 J.) CAST AS BASE WITH FULL HEIGHT WALLS.

STRUCTURE WEIGHTS:
 TOP SLAB.....3,875 LBS.
 BOTTOM SLAB w/ WALLS.....17,025 LBS.
 TOTAL CONCRETE WEIGHT.....20,900 LBS.

DESIGN SPECIFICS:
 A.) NO GROUND WATER
 B.) NO EARTH COVER

CITIZENS WATER STANDARD PRACTICE

Y.6

REVISION DATE: 10/03/2019

ISSUE DATE: 12/31/2019

6' X 10' X 7' VAULT FOR 4" DOMESTIC METERS

NOTE: OTHER PIPING CONFIGURATIONS MUST BE APPROVED BY THE UTILITY.

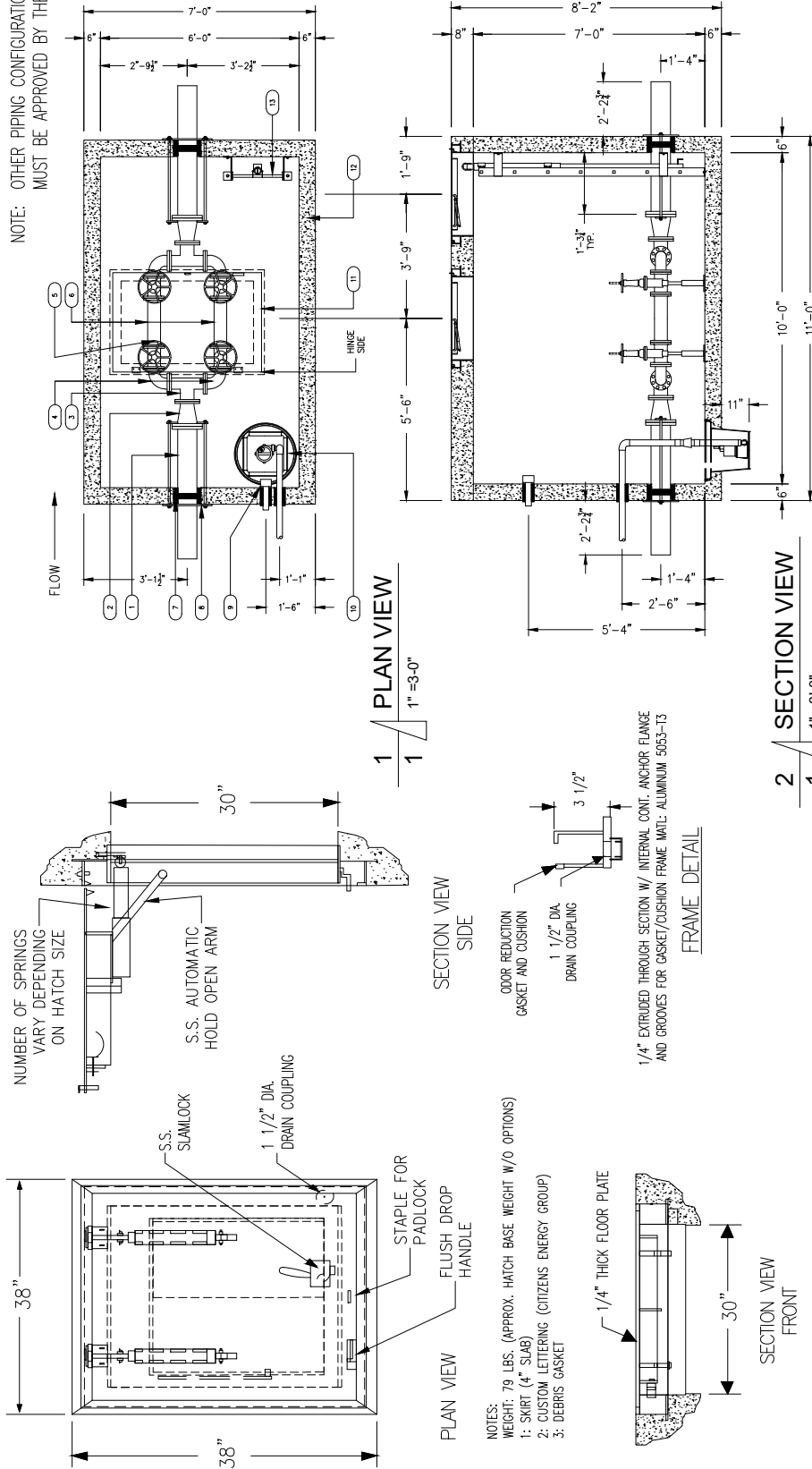

| ITEM | QTY. | DESCRIPTION |
|------|------|---|
| 1 | 2 | 8" x 48" LONG D.I. PIPE, FLG x P.E. |
| 2 | 2 | 8" x 6" REDUCER, FLANGED, D.I. |
| 3 | 2 | 4" x 4" x 6" TEE, FLANGED, D.I. |
| 4 | 4 | 4" DIA. ELBOW, FLANGED, D.I. |
| 5 | 4 | 4" DIA. OS & Y VALVE |
| 6 | 4 | 100% STAINLESS STEEL PIPE SUPPORT UNDER |
| 7 | 2 | 4" x 20 1/2" LONG SPOOL, FLG x FLG, DIA. FOR METER "HOLD" |
| 8 | 2 | FUTURE 4" SENSUS METER PROVIDED AND INSTALLED BY CITIZENS ENERGY GROUP, 4" x 20" LONG |
| 9 | 2 | 12" HOLE, FILLED w/ NON-SHRINK GROUT EACH SIDE |
| 10 | 2 | LINK SEAL FOR 8" D.I. PIPE |
| 11 | 2 | CUSTOM STEEL RESTRAINING PLATE, ASPHALTIC PRIMER COATED |
| 12 | 4 | 3/4" SS ALL THREAD, NUTS, LOCK AND FLAT WASHERS |
| 13 | 4 | IDUC LOGS |
| 14 | 1 | INEMA 4x JUNCTION BOX w/ LIQUID TITE CONNECTORS |
| 15 | 1 | 2" SCH 80 PVC CONDUIT, CAST-A-SEAL BOOT THROUGH WALL |
| 16 | 1 | SUMP PIT w/ GRADE, HOPE BY POLYLOK |
| 17 | 1 | SUMP PUMP ASSEMBLY w/ 1/3 HP, 115 VOLT, 1 PH LITTLE GIANT |
| 18 | 1 | AUTOMATIC PUMP, CONTINUOUS DUTY OR APPROVED EQUAL |
| 19 | 1 | 2" SCH 40 PVC "SILENT" CHECK VALVE w/ UNIONS FOR SUMP LINE |
| 20 | 1 | 2" SUMP DISCHARGE IN CAST-A-SEAL BOOT THROUGH WALL |
| 21 | 1 | 1.30" x 48" ALUM. HATCH, SPRING ASSIST, USF TFS, 3048 |
| 22 | 1 | 1.30" x 30" ALUM. HATCH, SPRING ASSIST, USF TFS, 3030 |
| 23 | 1 | 16"-10" ALUMINUM LADDER w/ (4) WALL MOUNTS, (2) FLOOR MOUNTS |
| 24 | 1 | ALUMINUM LADDER UP SAFETY DEVICE, POST TYPE |
| 25 | 6 | 3/8" STAINLESS ANCHOR BOLT |
| 26 | 6 | 3/8" STAINLESS WASHER |
| 27 | 6 | 3/8" STAINLESS NUT |

- PLAN NOTES**
- 1-MATERIAL ALUMINUM
 - 2-LOADING: 300 LBS. PER SQ. FT.
 - 3-316 STAINLESS STEEL BOLT, HINGES AND HOLD OPEN ARM
 - 4-AREA OF FRAME IN CONTACT WITH CONCRETE TO BE PAINTED WITH BITUMINOUS COATING.
- NOTES**
- VAULT TO BE SEALED AT JOBSITE w/ 2 1/4" x 3/4" BUTYL SEALANT.
 - SUMP PUMP REQUIRES A 20 AMP 120 VOLT, SINGLE PHASE CIRCUIT, PROVIDED BY OTHERS.
 - TO PREVENT EXCESSIVE CYCLING OF PUMP, A CHECK VALVE w/ UNIONS MUST BE INSTALLED AND SUMP DISCHARGE LINE ROUTED AWAY FROM VAULT TO NEAREST DRAIN.
 - TO PREVENT FLOTATION OF STRUCTURE, SUMP PIT IS NOT WATERTIGHT.
 - ELECTRICAL MUST BE HARD WIRED WITH G.F.I. AND MUST BE IN ACCORDANCE WITH LOCAL JURISDICTION'S ELECTRICAL CODE.
 - ALL VALVES AND BACKFLOW DEVICES MUST BE LEAD FREE.
 - VAULT MUST BE BEDDED IN #8 STONE FOR PROPER DRAINAGE.
- STANDARDS OF DESIGN:**
- 6" SIDEWALL AND FLOOR THICKNESS #4 & #5 REBAR-NO WIRE MESH TO BE USED.
 - 8" TOP SLAB THICKNESS - #5 @ 12" O.C. E-W.
 - CONCRETE MINIMUM COMPRESSIVE STRENGTH F_c = 5000 PSI @ 28 DAYS.
 - REINFORCING STEEL: ASTM A615, F_y = 60,000 PSI.
 - DESIGN SPECIFICATIONS: ACI 318.
 - DESIGN LOADING: NON-TRAFFIC BEARING.
 - INTERIOR DIMENSIONS - 4'-0" WIDE x 8'-0" LONG x 7'-0" TALL.
 - 12" MIN. FROM END WALLS TO FIRST JOINT - 18" FROM SIDE WALLS TO C/ OF PIPING, FITTINGS
 - 100% STAINLESS STEEL HARDWARE - NUTS, BOLTS, WASHERS, PIPE STANDS, ANCHORS, ETC.
 - CAST AS BASE WITH FULL HEIGHT WALLS.
- STRUCTURE WEIGHTS:**
- TOP SLAB.....3,875 LBS.
 BOTTOM SLAB w/ WALLS.....17,025 LBS.
 TOTAL CONCRETE WEIGHT.....20,900 LBS.
- NOTES:**
- NO GROUND WATER
 - NO EARTH COVER

CITIZENS WATER STANDARD PRACTICE

Y.7

REVISION DATE: 10/03/2019

ISSUE DATE: 12/31/2019

6' X 10' X 7' VAULT FOR FIRE METER

NOTE: OTHER PIPING CONFIGURATIONS MUST BE APPROVED BY THE UTILITY.

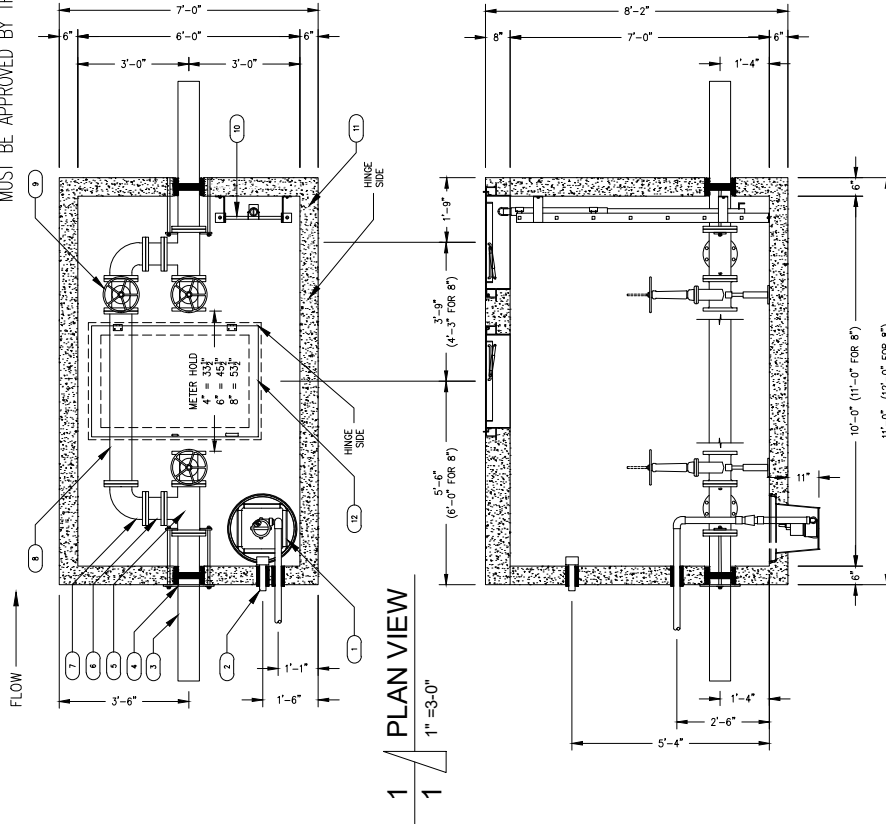

| ITEM | QTY. | PLAN NOTES | DESCRIPTION |
|------|------|------------|--|
| 1 | 1 | | SUMP PIT w/ GRADE, HOPE BY POLYLOK |
| 1 | 1 | | SUMP PUMP ASSEMBLY w/ 1/4 HP, 115 VOLT, 1 PH LITTLE GANT AUTOMATIC PUMP, CONTINUOUS DUTY OR APPROVED EQUAL |
| 1 | 2 | | 2" SCH 40 PVC "SILENT" CHECK VALVE w/ UNIONS FOR SUMP LINE |
| 1 | 2 | | 2" SUMP DISCHARGE IN CAST-A-SEAL BOOT THROUGH WALL |
| 2 | 1 | | NEMA 4X JUNCTION BOX w/ LIQUID TITE CONNECTORS |
| 1 | 2 | | 2" SCH 80 PVC CONDUIT, CAST-A-SEAL BOOT THROUGH WALL |
| 3 | 2 | | 4" x 6" x 8" x 46" LONG D.I. PIPE, FLO x P.E. |
| 4 | 2 | | CUSTOM STEEL RESTRAINING PLATE, ASPHALTIC PRIMER COATED |
| 4 | 2 | | LINK SEAL FOR D.I. PIPE GROUT EACH SIDE |
| 4 | 3/4" | | SS ALL THREAD, NUTS, LOCK AND FLAT WASHERS |
| 4 | 4 | | DUC LUGS |
| 5 | 2 | | 4" x 6" OR 8" TEL FLANGED, D.I. |
| 6 | 2 | | 4" x 6" OR 8" x 6" SPOOL FLANGED, D.I. |
| 7 | 4 | | 4" x 6" OR 8" ELBOW, FLANGED, D.I. |
| 8 | 1 | | FLANGE TO FLANGE D.I. PIPE |
| | | | 4" x 41 3/8" |
| | | | 6" x 55 7/8" |
| | | | 8" x 64 7/8" |
| 9 | 3 | | 4" x 6" OR 8" DIA. OS. & Y VALVE |
| 3 | 100% | | STAINLESS STEEL PIPE SUPPORT UNDER |
| 10 | 1 | | 6"-10" ALUMINUM LADDER w/ (4) WALL MOUNTS, (2) FLOOR MOUNTS |
| 1 | 1 | | ALUMINUM LADDER UP SAFETY DEVICE, POST TYPE |
| 6 | 3/8" | | STAINLESS ANCHOR BOLT |
| 6 | 3/8" | | STAINLESS WASHER |
| 11 | 1 | | 30" x 30" ALUM. HATCH, SPRING ASSIST, USF TFS 3030 |
| 12 | 1 | | 30" x 48" ALUM. HATCH, SPRING ASSIST, USF TFS 3048 |

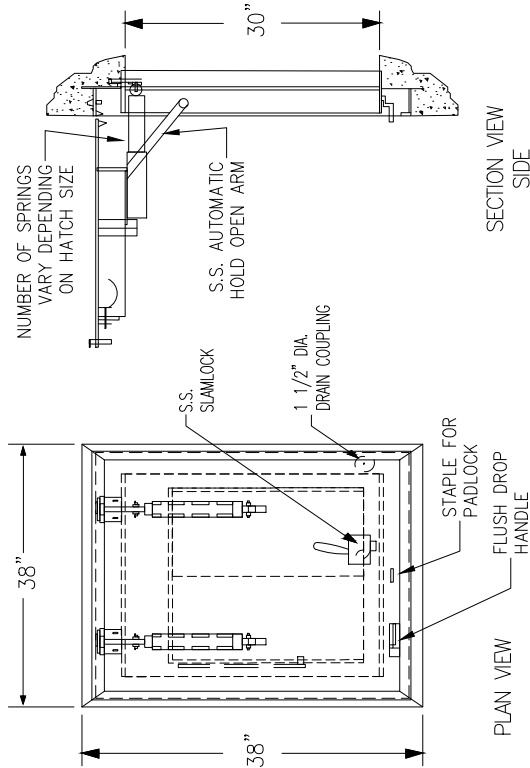

- NOTES:
 WEIGHT: 79 LBS. (APPROX. HATCH WEIGHT W/O OPTIONS)
 1: SKIRT (4" SLAB)
 2: CUSTOM LETTERING (CITIZENS ENERGY GROUP)
 3: DEBRIS GASKET

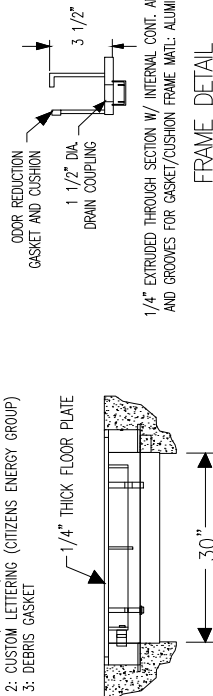

- NOTES:
 1- MATERIAL ALUMINUM
 2- LOADING: 300 LBS. PER SQ. FT.
 3- 316 STAINLESS STEEL BOLT HINGES AND HOLD OPEN ARM
 4- AREA OF FRAME IN CONTACT WITH CONCRETE TO BE PAINTED WITH BITUMINOUS COATING.

SECTION VIEW FRONT
 TFS 30" x 30" x 30"
 CLEAR OPENING: 29" x 30"

- NOTES:
 A.) VAULT TO BE SEALED AT JOBSITE w/ 2 1/4" x 3/4" BUTYL SEALANT.
 B.) SUMP PUMP REQUIRES A 20 AMP 120 VOLT, SINGLE PHASE CIRCUIT, PROVIDED BY OTHERS.
 C.) TO PREVENT EXCESSIVE CYCLING OF PUMP, A CHECK VALVE w/ UNIONS MUST BE INSTALLED AND SUMP DISCHARGE LINE ROUTED AWAY FROM VAULT TO NEAREST DRAIN.
 D.) TO PREVENT FLOTATION OF STRUCTURE, SUMP PIT IS NOT WATERTIGHT.
 E.) ELECTRICAL MUST BE HARD WIRED WITH G.F.I. AND MUST BE IN ACCORDANCE WITH LOCAL JURISDICTION'S ELECTRICAL CODE.
 F.) ALL VALVES AND BACKFLOW DEVICES MUST BE LEAD FREE.
 G.) VAULT MUST BE BEDDED IN #8 STONE FOR PROPER DRAINAGE.

- STANDARDS OF DESIGN:
 A.) 6" SIDEWALL AND FLOOR THICKNESS #4 & #5 REBAR-NO WIRE MESH TO BE USED.
 B.) 8" TOP SLAB THICKNESS - #5 @ 12" O.C. E.W.
 C.) CONCRETE MINIMUM COMPRESSIVE STRENGTH F_c = 5000 PSI @ 28 DAYS.
 D.) REINFORCING STEEL: ASTM A615, F_y = 60,000 PSI.
 E.) DESIGN SPECIFICATIONS: ACI 318.
 F.) DESIGN LOADING: NON-TRAFFIC BEARING.
 G.) INTERIOR DIMENSIONS - 4'-0" WIDE x 8'-0" LONG x 7'-0" TALL.
 H.) 12" MIN. FROM END WALLS TO FIRST JOINT - 18" FROM SIDE WALLS TO CENTER OF PIPING, FITTINGS.
 I.) 100% STAINLESS STEEL HARDWARE - NUTS, BOLTS, WASHERS, PIPE STANDS, ANCHORS, ETC.
 J.) CAST AS BASE WITH FULL HEIGHT WALLS.

- DESIGN SPECIFICS:
 A.) NO GROUND WATER
 B.) NO EARTH COVER
- STRUCTURE WEIGHTS:
 TOP SLAB.....3,875 LBS.
 BOTTOM SLAB w/ WALLS.....17,025 LBS.
 TOTAL CONCRETE WEIGHT.....20,900 LBS.

CITIZENS WATER STANDARD PRACTICE

Y.8

REVISION DATE: 10/03/2019

ISSUE DATE: 12/31/2019

6' X 10' X 7' VAULT FOR COMBINATION FIRE AND DOMESTIC SERVICES

NOTE: OTHER PIPING CONFIGURATIONS
MUST BE APPROVED BY THE UTILITY.

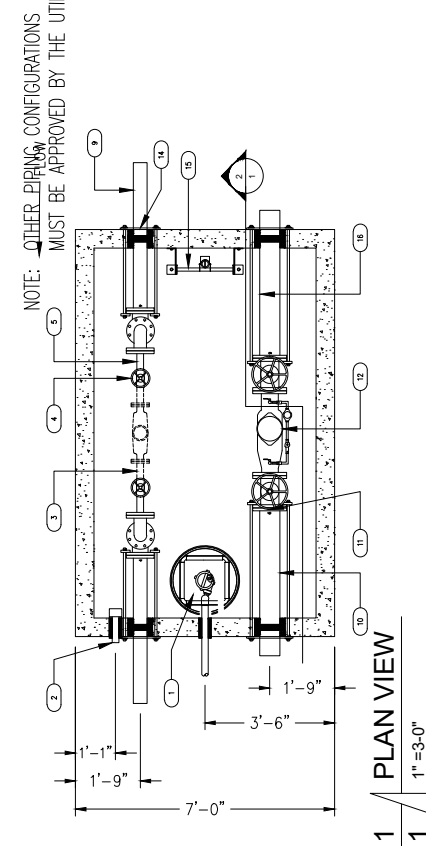

1 PLAN VIEW
1" = 3'-0"

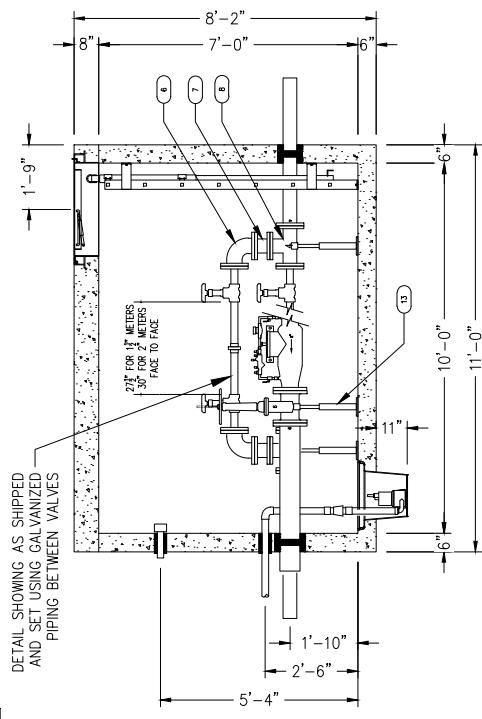

2 SECTION VIEW
1" = 3'-0"

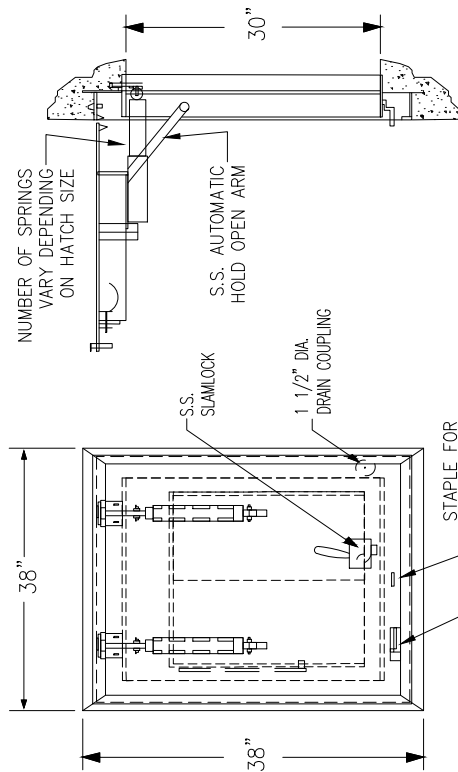

PLAN VIEW
38" x 38" overall hatch size
30" diameter opening

NOTES:
WEIGHT: 79 LBS. (APPROX. HATCH BASE WEIGHT W/O OPTIONS)
1- SKIRT (4" SLAB)
2- CUSTOM LETTERING (CITIZENS ENERGY GROUP)
3- DEBRIS GASKET

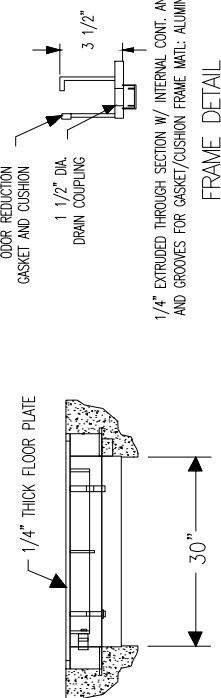

SECTION VIEW FRONT
30" x 30" opening

NOTES:
1- MATERIAL ALUMINUM
2- LOADING: 300 LBS. PER SQ. FT.
3- 316 STAINLESS STEEL BOLT HINGES AND HOLD OPEN ARM
4- AREA OF FRAME IN CONTACT WITH CONCRETE TO BE PAINTED WITH BITUMINOUS COATING.

1/4" EXTRUDED THROUGH SECTION W/ INTERNAL CONT. ANCHOR FLANGE AND GROOVES FOR GASKET/CUSHION FRAME MATL: ALUMINUM 5053-T3

FRAME DETAIL

| ITEM | QTY. | DESCRIPTION |
|------|------|---|
| 1 | 1 | SUMP PIT W/ GRADE, HDPE BY POLYLOCK |
| 1 | 1 | SUMP PUMP ASSEMBLY W/ 1/3 HP, 115 VOLT, 1 PH LITTLE GIANT AUTOMATIC PUMP, CONTINUOUS DUTY OR EQUAL APPROVED |
| 1 | 2' | SCH 40 PVC "SILENT" CHECK VALVE W/ UNIONS FOR SUMP LINE |
| 1 | 1 | SUMP DISCHARGE IN CAST-A-SEAL BOOT THROUGH WALL |
| 2 | 1 | NEMA 4X JUNCTION BOX W/ LIQUID TITE CONNECTORS |
| 3 | 4 | 2" SCH 80 PVC CONDUIT, CAST-A-SEAL BOOT THROUGH WALL |
| 4 | 4 | FUTURE 1 1/2" OR 2" BRASS NIPPLE - 6 1/2" LONG - MP x BALD |
| 4 | 4 | FUTURE 1 1/2" OR 2" BRASS LOC-PAK COUPLER - METER FLANGE x LOC-PAK |
| 2 | 2 | FUTURE METER |
| 4 | 4 | 1 1/2" OR 2" NPT BRASS GATE VALVE - RISING STEM - LEAD FREE - TO BE INSTALLED AT 45° ANGLE |
| 5 | 4 | 1 1/2" OR 2" NPT x 3" BRASS NIPPLE |
| 6 | 2 | 3" OR 4" DIA. ELBOW, FLANGED, D.I. |
| 7 | 2 | 3" OR 4" DIA. TEEL, FLANGED, D.I. |
| 8 | 2 | 3" OR 4" DIA. TEEL, FLANGED, D.I. |
| 9 | 2 | 3" OR 4" DIA. TEEL, FLANGED, D.I. |
| 10 | 2 | 4" DIA. x VARIES D.I. PIPE |
| 11 | 2 | 4" DIA. x VARIES D.I. PIPE |
| 12 | 4 | 100% STAINLESS STEEL PIPE SUPPORT |
| 13 | 4 | 100% STAINLESS STEEL RESTRAINING PLATE, ASPHALTIC PRIMER COATED |
| 14 | 4 | CUSTOM STEEL RESTRAINING PLATE, LOCK AND FLAT WASHERS |
| 8 | 8 | DUC LUGS |
| 4 | 4 | LINK SEAL W/ GROUT EACH SIDE |
| 15 | 1 | 6"-10" ALUMINUM LADDER # (4) WALL MOUNTS, (2) FLOOR MOUNTS |
| 1 | 1 | ALUMINUM LADDER UP SAFETY DEVICE, POST TYPE |
| 6 | 6 | 3/8" STAINLESS ANCHOR BOLT |
| 6 | 6 | 3/8" STAINLESS WASHER |
| 16 | 1 | 30" x 30" ALUM. HATCH, SPRING ASSIST, USF TFS 3030 |

NOTES:
A.) VAULT TO BE SEALED AT JOBSITE W/ 2 1/4" x 3/4" BUTYL SEALANT.
B.) SUMP PUMP REQUIRES A 20 AMP 120 VOLT, SINGLE PHASE CIRCUIT, PROVIDED BY OTHERS.
C.) TO PREVENT EXCESSIVE CYCLING OF PUMP, A CHECK VALVE W/ UNIONS MUST BE INSTALLED AND SUMP DISCHARGE LINE ROUTED AWAY FROM VAULT TO NEAREST DRAIN.
D.) TO PREVENT FLOATION OF STRUCTURE, SUMP PIT IS NOT WATERTIGHT.
E.) ELECTRICAL MUST BE HARD WIRED WITH G.F.I. AND MUST BE IN ACCORDANCE WITH LOCAL JURISDICTION'S ELECTRICAL CODE.
F.) ALL VALVES AND BACKFLOW DEVICES MUST BE LEAD FREE.
G.) VAULT MUST BE BEDDED IN #8 STONE FOR PROPER DRAINAGE.

STANDARDS OF DESIGN:
A.) 6" SIDEWALL AND FLOOR THICKNESS #4 & #5 REBAR-NO WIRE MESH TO BE USED.
B.) 8" TOP SLAB THICKNESS - #5 @ 12" O.C. E.W.
C.) CONCRETE MINIMUM COMPRESSIVE STRENGTH F_c = 5000 PSI @ 28 DAYS.
D.) REINFORCING STEEL: ASTM A615, F_y = 60,000 PSI.
E.) DESIGN SPECIFICATIONS: ACI 318.
F.) DESIGN LOADING: NON-TRAFFIC BEARING.
G.) INTERIOR DIMENSIONS - 4'-0" WIDE x 8'-0" LONG x 7'-0" TALL.
H.) 12" MIN. FROM END WALLS TO FIRST JOINT - 18" FROM SIDE WALLS TO C/ OF PIPING, FITTINGS.
I.) 100% STAINLESS STEEL HARDWARE - NUTS, BOLTS, WASHERS, PIPE STANDS, ANCHORS, ETC.
J.) CAST AS BASE WITH FULL HEIGHT WALLS.

STRUCTURE WEIGHTS:
NO GROUND WATER
TOP SLAB.....3,875 LBS.
BOTTOM SLAB W/ WALLS.....17,025 LBS.
TOTAL CONCRETE WEIGHT.....20,900 LBS.

CITIZENS WATER
STANDARD PRACTICE

Z

REVISION DATE: 11/14/2019

ISSUE DATE: 12/31/2019

POLYETHYLENE SERVICE LINE METER SUPPORT

